

LANDSCAPE & URBAN DESIGN

67

May/June 2024

Price £4⁹⁵

landud.co.uk



Cotswold Company Garden Furniture

A beautifully curated collection
of outdoor furniture for Summer

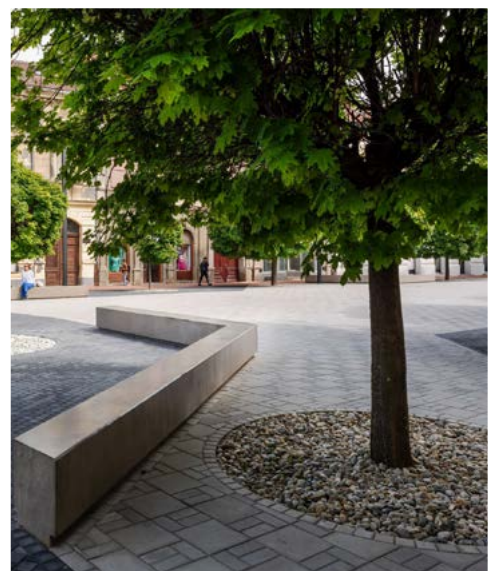

Showcase your skills at this year's National Landscape Awards

A valuable investment for landscape professionals and businesses
looking to make a lasting impact on the industry

Reconstruction of Central Squares

An urban collage of possibilities
across three zones in Koprivnica



HARDSCAPE

Inspire. Select. Supply.

Commercial Stone & Paving Inspiring Urban Spaces for 30 years

enq@hardscape.co.uk

01204 565 500

Cadence, King's Cross, London

CONTENTS ISSUE 67

THIS ISSUES MAIN FEATURES



Bound Surfacing | 48 - 51



Concrete & Stonework | 52 - 57



Landscaping Services | 62 - 63

Decking

4 - Top tips to keep your composite decking project on budget, so you can enjoy your garden space for less.

6 - Gripsure, a leader in non-slip decking solutions, has been revolutionising the landscaping sector with its bespoke bamboo decking and cladding.

Garden Design

14 - Experts reveal the top patio and garden trends to transform your space this year.

18 - How Next-Generation Technology is Shaping Landscape and Urban Design.

20 - Introducing The Cotswold Company Garden Furniture Collections for Summer 2024.

24 - Take outdoor grilling and entertaining to the next level with Cabinex outdoor kitchens.

38 - DuraPost® Prima Composite Board now features a recycled PVCu core, meaning installers can help their customers to achieve an overall more sustainable fencing solution.

Bound Surfacing

50 - Addagrip are committed to enriching communities and fostering sustainable environments through charitable initiatives.

Concrete & Stonework

52 - Elite Precast Concrete has introduced their Elite Verti-Crete fencing and walling.

55 - Stoneworld: Redefining Excellence in Urban and Landscape Design.

Green & Blue Infrastructure

58 - The reconstruction of Central Squares in Koprivnica, Croatia.

Landscaping Services

62 - Showcase your skills at this year's National Landscape Awards.

64 - Blooming urban landscapes from Pictorial Meadows.

66 - Finning is showing support for an exciting new addition to the show gardens at RHS Malvern Spring Festival by donating one of the latest Cat® next generation mini excavators to carry out groundworks for the innovative creation.

68 - Take your landscape to new heights with Otterbine's giant fountains.

Sport & Play

82 - A non-prescriptive form of play, the Playspaces pole climbers are fast becoming one of their most popular product types.

Groundskeeping

94 - Behind the Scenes - The Rigorous Safety Testing of Trimax Mowers Unveiled.

Accredited
Members
of BALI



Publishing Director

Martin Holmes
martin@mhmagazine.co.uk

Sales Director

Lee Martin
lee@landud.co.uk

Digital Manager

Jamie Bullock
jamie@mhmagazine.co.uk

Editor-in-Chief

Antony Holter
editor@mmhmagazine.co.uk

Editor

Lorna Davidson
lorna@landud.co.uk

Business Manager

Josh Holmes
josh@mhmagazine.co.uk

Studio Designer

Sarah Johnson
sarah.johnson@mhmagazine.co.uk

Marketing Enquiries - 01227 936974
Editorial Enquiries - 01304 806039
Other Enquiries - 01304 806039

Publishers

MH Media Global Ltd.
18/20 Newington Road,
Ramsgate Kent CT12 6EE

Cover images courtesy of: Left: Regent's Place Phase Two ©Paul Upward Photography | Top Right: The Cotswold Company | Bottom Right: NFO Architects

Every effort is made to ensure the accuracy and reliability of material published in Landscape & Urban Design however, the publishers accept no responsibility for the claims or opinions made by advertisers, manufacturers or contributors. No part of this publication may be reproduced or transmitted in any form or by any means, mechanical, electronic (including photocopying) or stored in any information retrieval system without the prior consent of the publisher.

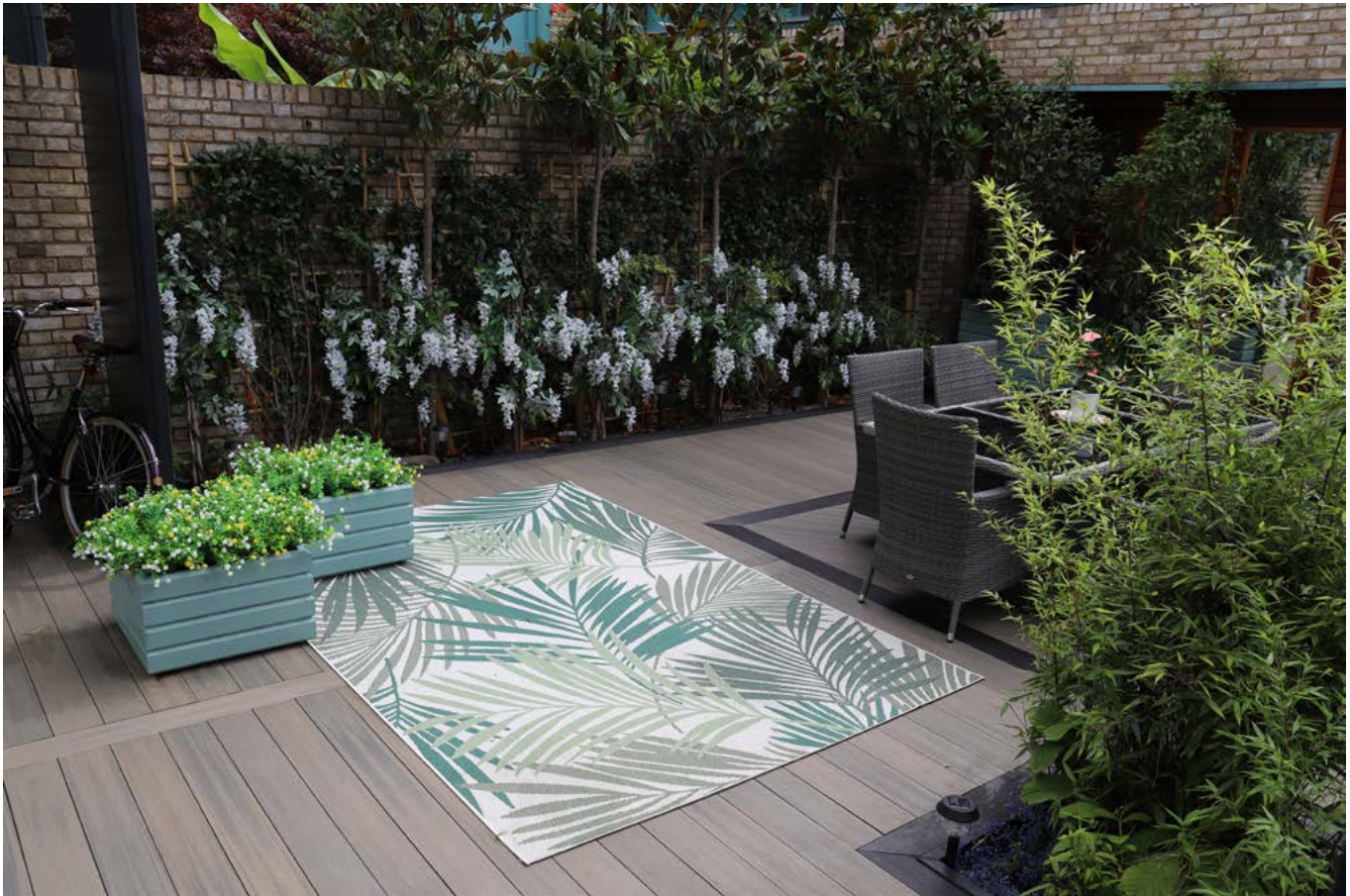

COMPOSITE DECKING ON A BUDGET

When looking to embark on a garden renovation, it's a great idea to build decking, to help level any awkward, tiered ground, and modernise the entire space. Composite decking is an incredibly popular choice due to its long lasting, low maintenance qualities,

whilst still looking and feeling like real wood. In this article, we're exploring our top tips to keep your composite decking project on budget, so you can enjoy your garden space for less. Let's take a look.

1. Composite decking: What's on the market?

There are plenty of composite decking products available on today's market, all at different price points, so it is important to thoroughly investigate what is right for your space. We believe

the smart money is NeoTimber's range of composite decking for the impressive quality of the material, and its price range. With a broad variety of different profiles, colours, and textures, there is a NeoTimber decking solution for every kind of outdoor space.

NeoTimber offer both solid and hollow decking boards, with the hollow boards being less expensive - ideal for a project on a budget. Hollow boards are perfect for most garden projects, while solid decking boards offer additional strength for decking areas that might be supporting something, particularly heavy, like a hot tub. NeoTimber's composite decking comes with up to 25-years warranty for residential use, so it less likely to need expensive replacements further down the line.

2. Explore subframe alternatives

Though we would usually recommend using a composite subframe for sheer longevity, you can choose to install our composite

decking on top of a timber frame to help cut costs. To make sure it withstands the tests of time, make sure to specify pressure-treated timber so that the frame doesn't rot.

Alternatively, you can apply our joist tape on top of the timber, to give it additional protection. To support the structure of the decking frame, you can also buy plastic lumber, which still works perfectly in conjunction with a timber subframe alternative.

3. Keep it simple and keep costs down

There are many different laying patterns that you can use with your decking boards, but sometimes, to be more cost effective, the simplest way is better. Though diagonal runs and curved edges can look incredibly smart, a more standardised, linear decking installation will mean you are less likely to need to cut down your boards down to size, limiting the amount of wastage.



If your heart is set on a more interesting decking pattern design, make sure to keep any off cuts - these can make great fascia boards or decking edges. We recommend doing your homework prior to purchasing to work out exactly what you need. NeoTimber even have a handy calculator on their website, to help you to work out an estimate of your requirements.

4. Do it yourself!

NeoTimber has an approved installer scheme, with a list of builders and tradesmen trusted with the specifics of laying composite decking. However, if you want keep to the your budget, you can build the decking yourself, and save on those additional installation costs.

Not sure on where to start? Don't worry; all of NeoTimber's decking is designed to be an intuitive, easy to build system, with simple installation instructions, practical advice, and step-by-step videos available on the website.

To conclude, there are plenty of ways to keep your composite decking project on budget. By choosing affordable, hollow boards, installing the products yourself (it's easier than you think), and laying them in a linear pattern to reduce wastage, there's no reason why you can't have a high-quality, long-lasting, great looking decking area on a tight budget.

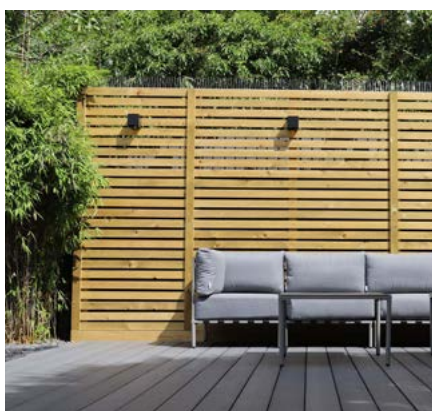
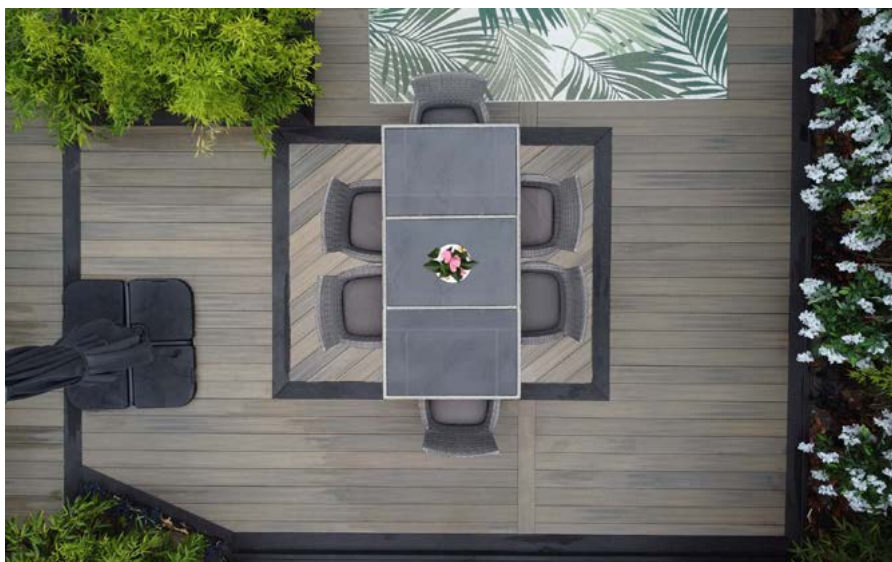

STEP INTO SUSTAINABILITY: GRIPSURE'S BAMBOO DECKING AND CLADDING REDEFINES LANDSCAPING



Gripsure, a leader in non-slip decking solutions, has been revolutionising the landscaping sector with its bespoke bamboo decking and cladding. Offering durability and finish comparable to hardwood, without the environmental impact, bamboo is heralded as the next step in eco-architecture, making it the perfect choice for recent projects in Lewisham and Paultons Park.

Paultons Park, a beloved UK theme park, required flooring that could withstand heavy foot traffic in all weather conditions without compromising on environmental responsibility. Gripsure's Bamboo N-Durance® and X-treme® anti-slip decking was installed throughout the park, ensuring safety and aesthetic appeal. These decks were used in queueing areas, loading platforms, an external garden walkway, and a balcony, providing safe footing for staff and visitors alike. Gripsure's bamboo decking offers longevity and sustainability, with up to a 25-year warranty, and is resistant to rotting and mould, unlike the park's previous rubber crumb solution.

James Mancey, deputy managing director of Paultons Park, expressed his satisfaction with Gripsure's bamboo decking, stating "I am very pleased to see our collaboration with Gripsure bring to life our vision of combining safety, aesthetics, and environmental sustainability within our theme park. The introduction of Gripsure's bamboo decking across our site not only enhances the visual appeal of our park but also aligns with our commitment to providing a safe, enjoyable and eco-friendly experience for all our visitors," added Mr Mancey. "This initiative reflects our dedication to innovation and our responsibility towards the planet, ensuring Paultons Park remains a cherished destination for families, while leading by example in environmental stewardship."

Meanwhile, in Lewisham, Gripsure's bamboo decking and cladding were chosen for a variety of applications throughout a new development



of flats, proving to be the ideal solution by meeting the project's aesthetic, safety, and sustainability requirements. Bamboo X-treme® deck boards were used for the flooring of external pergolas with outdoor seating, while cladding was installed as a stylish finish for raised planters in the garden areas. This sustainable decking provides a non-slip surface, ensuring safety and enjoyment for residents in all weather conditions, while the cladding protects against weathering and adds a sophisticated touch to the area.

www.gripsure.co.uk

Bamboo: Beauty with a conscience.

Step into a world where
style meets responsibility.

Known for its strength, resilience, and timeless elegance, our bamboo decking and cladding collections are crafted from one of the world's most rapidly renewable resources, transforming outdoor spaces into a harmonious blend of luxury and environmental consciousness. Redefine the art of outdoor living without compromise.

- ✓ Fire rated
- ✓ Co2 neutral
- ✓ Hard & durable
- ✓ Beautiful appearance
- ✓ Easy installation
- ✓ High stability
- ✓ Endless resource
- ✓ Maintenance free

© Reily Imagery

Discover the beauty of bamboo and order your
free decking and cladding sample today.

www.gripsure.co.uk info@gripsure.co.uk 01726 844616

 **GRIPSURE**[®]
keeps you on your feet



CASE STUDY: LUXURY OUTDOOR SPACES WITH TREKKER AT ARMATHWAITE HALL

Nestled in the stunning Lake District, a stone's throw from the calming waters of Bassenthwaite Lake and overlooked by the dramatic Skiddaw Mountain, Armathwaite Hall Hotel is the perfect location for a luxurious getaway.

With outstanding views of the countryside and set within 400 acres of deer park, this stunning hotel was looking to create a luxurious and relaxing space for its guests to take in the surroundings.

In May 2023, the multi-award winning Armathwaite Hall Hotel & Spa unveiled the completion of its £1.5

million investment into its luxury offering and Trekker was delighted to have its decking products specified as part of the project for the balconies and terrace areas.

Set in close proximity to the main house and boasting a substantial floor footage spanning an impressive 40-50sqm, the new Spa Garden Suites offer seamless access to the hotel's award-winning spa facilities. Guests can immerse themselves in an oasis of tranquillity as each suite integrates with the lush, verdant landscape just beyond its doors and accessible via a private patio.

With luxury and tranquillity at the heart of this regeneration project, it was important that this was reflected in the decking areas. The client decided that the Trekker Anthracite Woodgrain Composite Decking would be the perfect fit for the luxurious yet traditional feel of the rooms. With an area of 214m² to cover, this product provides not only a dramatic visual uplift but is easier to maintain than timber alternatives and is more hard wearing in a potentially highly trafficked area.

This decision wasn't just based on style, the practicality of the products used was equally important. With anti-slip properties, the Anthracite Woodgrain is an ideal choice for hotels and hospitality where the safety of guests is paramount - meaning the area can now be enjoyed all year round.

The design of the Spa Garden Suites takes inspiration from the hotel's natural environment and the Trekker woodgrain decking fits perfectly with its raw, natural, timber-inspired look and feel.



To find out more about how Trekker can enhance your next project, visit www.trekkerglobal.com 01483 310 800 info@trekkerglobal.com



Up to
**25 year
warranty**

Introducing Endura:

Your Ultimate Decking & Cladding Solution

Crafted from natural timber and 100% recyclable, enjoy peace of mind with up to 25 year warranty. Splinter-free, slip-resistant, and incredibly durable, it's the perfect choice for both domestic commercial projects.

Explore the range today!

TREKKER
LUXURY DECKING & CLADDING

T. +44(0)1483 310800

www.trekkerglobal.com



Sourcing for your next decking project?

Look for the Mark



Find third-party verified and fit-for-purpose products and installers

From deck components and design engineers to wood coating solutions and specialised fixings.



Gripsure



Tite-Fix: DeckTite



Cheshire Mouldings

DeckMark schemes require a full business audit and assessment followed by annual surveillance audits by TDCA.

The Timber Decking & Cladding Association is an independent, not-for-profit technical and advisory trade body. Recognised as the authoritative source of expert opinion in the UK.

Get in touch and find a supplier today

info@tdca.org.uk | 01977 558147

www.tdca.org.uk

IS YOUR DECK CLEAN AND READY FOR THE SEASON?

It's a fact that all outdoor flat surfaces need routine cleaning to keep them free of dirt and debris. Such cleaning also keeps mildew, algae and fine mosses at bay which are the cause of slippery conditions in damp or wet environments - a problem with most porous or semi-porous decking materials.

In terms of timber, a stiff brush and a mild soap solution is usually all you need. WPC decks may need specialised cleaning products - always follow the manufacturer's guidance.



Choose a dry day and methodically work the grime loose before rinsing with clean water. Allow the deck to dry prior to any further treatment. If a protective finish has been applied to the timber, then this should be reapplied.

You might consider professional cleaning or using a pressure washer - there are specific deck cleaning attachments available. A timber surface can be damaged if the pressure used is too high. Choose a lower pressure and don't put the lance too close to the deck's surface.

If the deck is heavily stained, use a proprietary cleaning product. There are several DeckMark Approved products available from TDCA members which can clean and refresh the wood's appearance, as well as protective products to help prevent staining. Which products you use will depend on your timber type - always check with the manufacturer.

Don't forget to look for loose or damaged boards and fixings and periodically check under the deck to ensure the substructure is still sound. Get into the habit of sweeping away any debris and mopping up spilled food as and when it occurs.

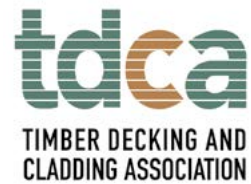

For further technical advice and details of DeckMark approved products and services, visit: www.tdca.org.uk

Look for TDCA Approved Products



AkzoNobel

Barrettine
TRUSTED BY THE PROFESSIONALS

OWATROL
ADD LIFE TO YEARS

STIHL



GET A FREE AP BATTERY FROM STIHL

DOUBLE THE BATTERY. DOUBLE THE OUTPUT.

POWER UP WITH STIHL THIS SPRING.

Buy any AP System tool with an AP 200 or AP 300 S battery and receive the same battery free!



Available from your local STIHL Approved Dealer. Whilst stocks last.

FIND OUT MORE AT [STIHL.CO.UK](https://www.stihl.co.uk)

APIII
SYSTEM

BATTERY POWER. BY STIHL.



MEDITE MAKES IT REAL

THE GO-TO HUB FOR MDF ENTHUSIASTS

MEDITE SMARTPLY's digital platform, MEDITE Makes It Real, is the go-to hub for MDF enthusiasts. It provides a professional network for MEDITE users to showcase their innovative creations and draw inspiration from MDF's versatile applications. The members-only platform is open to landscape architects, garden designers, urban planners, outdoor living space designers and anyone interested in MDF.

At the heart of the MEDITE Makes It Real community is the inspiration drawn from projects ranging from intimate landscape solutions to grand installations. For example, at the RHS Chelsea Flower Show 2022, MEDITE SMARTPLY partnered with renowned designer Sarah Eberle to feature a centrepiece crafted from MEDITE TRICOYA EXTREME (MTX). This installation received the Gold and Best Construction Award (Show Garden).

The MTX centrepiece, inspired by natural vertical rock strata,

combined aesthetic appeal with environmental resilience, highlighting the versatility of wood panels in challenging weather conditions. This remarkable material, guaranteed for up to 50 years above ground and 25 years in ground, demonstrates MEDITE SMARTPLY's commitment to innovation and sustainability.

The use of thoughtfully engineered wood panels is central to developing environmentally conscious solutions for the built environment. Timber products, which have the lowest embodied carbon of any mainstream building material, lock CO₂ within the panels, aligning innovative ideas with sustainable practices.

The MEDITE range features many variants of MDF panels including flame retardant and moisture resistant solutions, with hundreds of possible specifications. Through consistent focus on research, development and technological advancement, MEDITE has

established itself as a leading brand in the MDF market, continually introducing high-quality, customer-oriented products.

Holly Waters-Marsh, Head of Marketing at MEDITE SMARTPLY, stated, "MEDITE MDF is now bigger and better than ever. It helps you to realise many of your creative ideas, providing the right material for numerous applications you may have envisioned but struggled to find the perfect match for. That is why we are excited to spearhead the industry community - MEDITE Makes It Real is the ideal forum for the industry to see dreams become reality." Joining MEDITE Makes It Real is free, and new members receive an exclusive gift as a welcome.

To join the MEDITE MDF community and stay updated with the latest exclusive news and innovations, visit meditemakesitreal.com.

MEDITE® makes it real

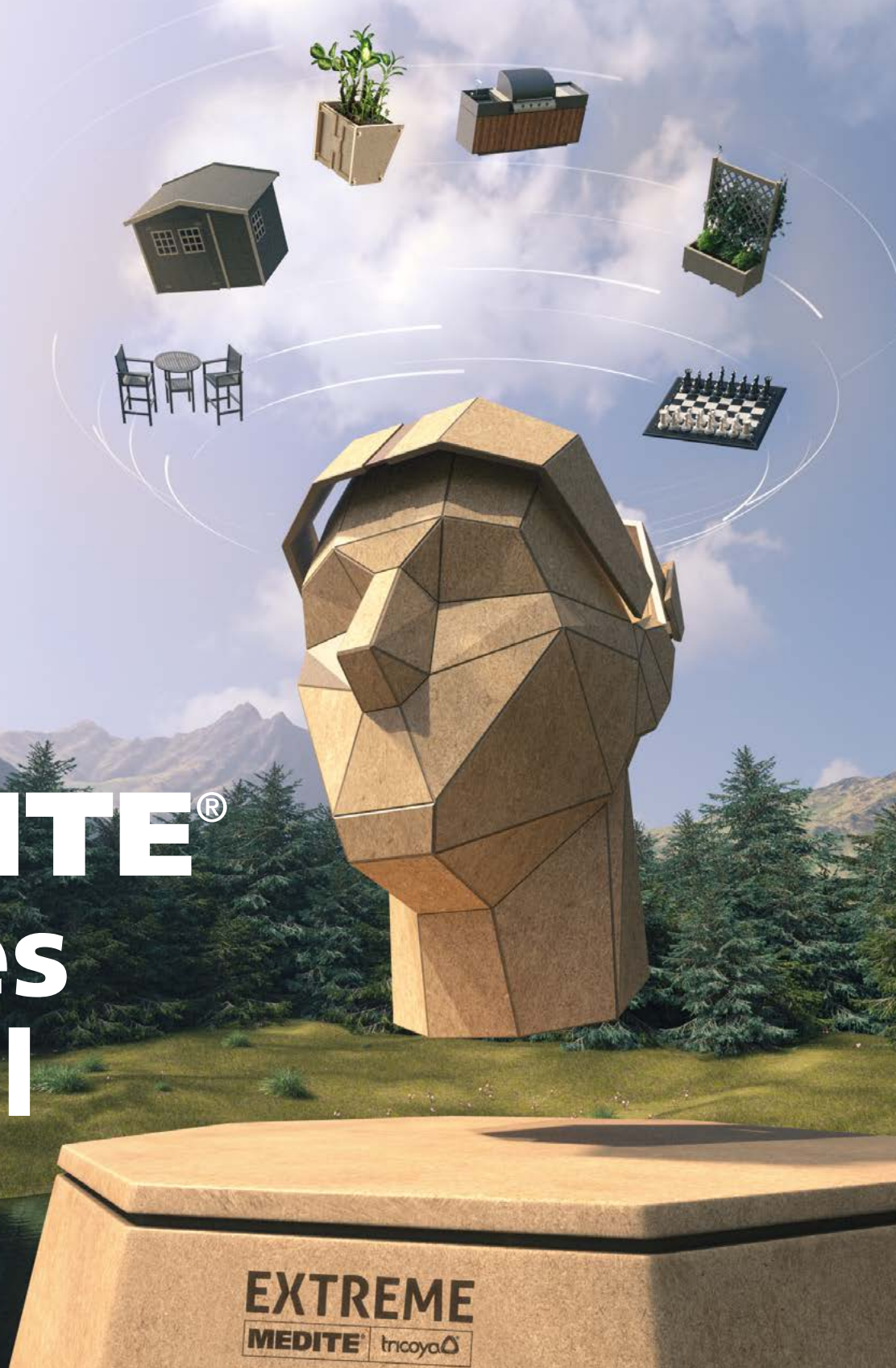

MEDITE is the leading MDF brand in the wood panel industry. Its extensive range includes MEDITE® TRICOYA® EXTREME (MTX), an innovative panel that has taken the construction, landscaping and design world by storm. Guaranteed for up to 50 years outside and 25 years below ground, this high-performance material is incredibly versatile and can be used for planters, garden rooms, sculptures, playgrounds, building façades, furniture; your imagination is the only limit!

Sourced from sustainably managed forests, our engineered wood panels are proof of our commitment to creating products that contribute to sustainable and healthier environments. Renowned for their versatility as much as their durability, our products are suitable for a multitude of applications.

Join the MEDITE MDF community online to receive the latest updates and a sign-up gift.

Visit meditemakesitreal.com for more information.

Dreamers welcome!



MEDITE®



EXPERTS REVEAL THE TOP PATIO AND GARDEN TRENDS TO TRANSFORM YOUR SPACE THIS YEAR

As the days begin to get brighter and longer, people will begin to think about how they can revamp their exterior space to get ready for the warmer months ahead.

From mediterranean inspiration to rewilding outdoor spaces, the experts at Stone Superstore predict that garden design trends are set to evolve from minimalist spaces

to wilder and naturally informal styles, where nature, sustainability and wellness is prioritised. Creative director Molly Woodward-Moor shares the top five trends that we'll be seeing in outdoor spaces this year.

Alfresco Entertaining

With the cost of eating out continuing to rise, we're increasingly

looking to create our own spaces of 'at-home luxury' to find these moments of escapism or ways to entertain friends and family. Outdoor kitchens and built-in barbeque areas are becoming a popular consideration within people's garden design checklist, along with firepits, pizza ovens, counter space, and even wine/beer fridges.



To create an inviting, and stylish outdoor cooking or dining area that you will want to spend time using, it's important to factor in practicality. Overhead garden structures, such as pergolas and awnings, have started to re-trend over recent years, offering shelter from the temperamental British weather, while providing a sense of enclosure and much needed privacy.

When it comes to functionality, opting for a durable and easy-to-clean flooring material, such as porcelain paving tiles, is a must-have for exterior dining areas, ensuring food and drink spills are easy to clean without marking your external flooring. For those looking to take their design creativity to the next level, try incorporating patterned paving into your patio to zone the dining seating area from the rest of your garden area.



Rewilding

Ideal for low-maintenance gardeners, the rewilding trend is a sustainable gardening approach that encourages wildlife and pollinators to thrive, immersing our space with nature in a grounding and authentic way.

From growing flowers, incorporating shelter for wildlife to using natural stone materials, it's about making smart design choices that benefits wildlife within your outdoor space.

This trend encourages scattering native wildflower seeds into your planting beds to benefit local wildlife, that in turn creates a vibrant and romantic ambience to your garden that is also very low maintenance. Additionally, reducing lawn mowing and introducing home composting works well here to enrich the soil with valuable nutrients in an easy way.

Urban Gardens

More people are seeking to transform their outdoor space into their own sanctuary where they can nurture plants, grow home produce, and relax.



The key to designing an urban terrace or balcony is to maximise the space you have available. Most people tend to overlook exterior walls however, creating a vertical garden will allow you to incorporate colour and nature into a small space.

You can utilise exterior walls with the use of hanging planters, wall-mounted shelving and even using patterned tiling to add colour and dimension to the space. Additionally, outdoor mirrors work particularly well for this trend, giving the illusion of a larger area whilst also brightening up your space.

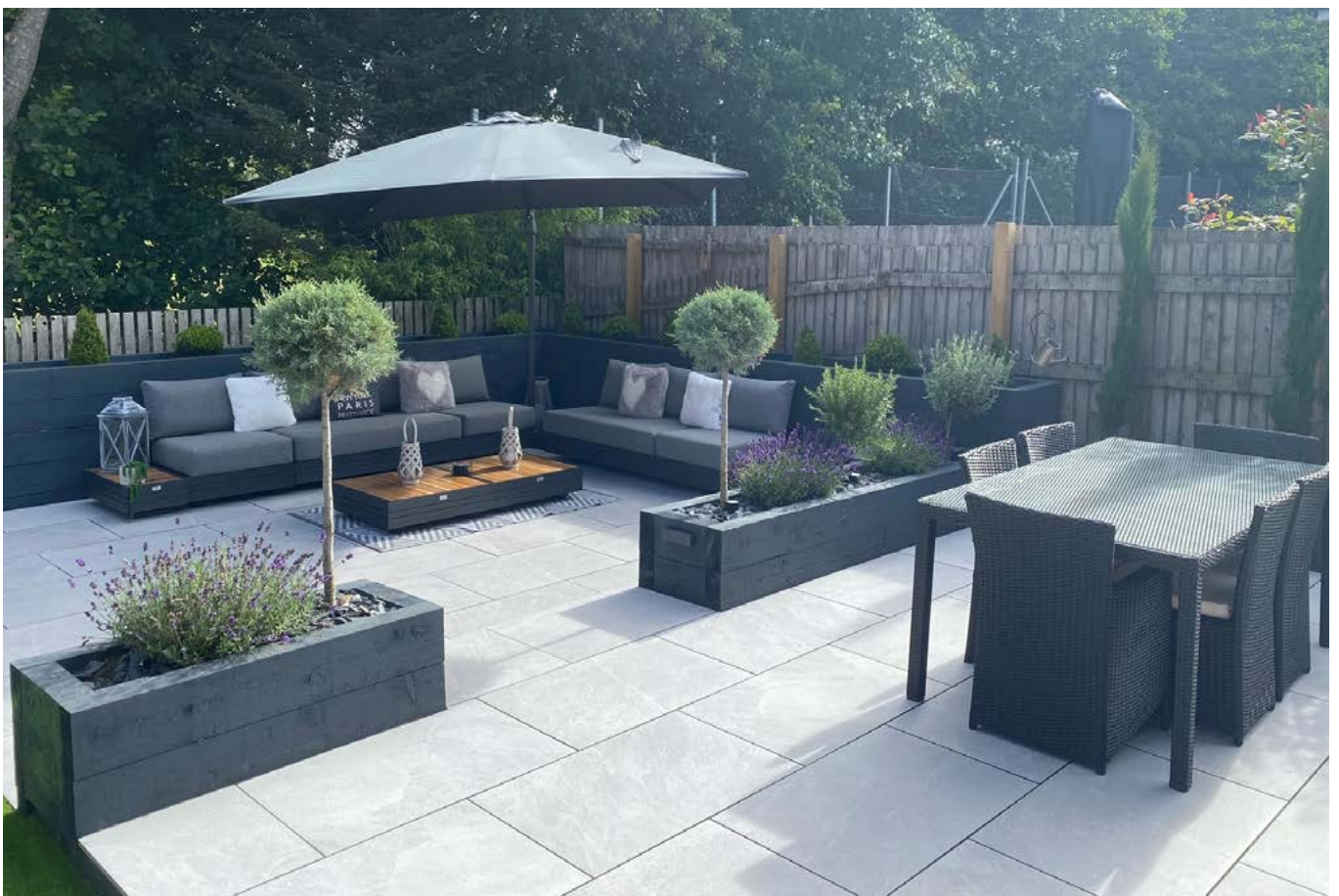



Indoor/Outdoor Living

The positive health and wellness effects of nature are undeniable, and we're continuing to blur the boundaries between our indoor and outdoor spaces to optimise these benefits. Look to create seamless transitions with large sliding doors, continuous floors of indoor outdoor tiles and flowing colour palettes to visually link these spaces.

The boundaries between our interior and exterior living spaces will become even more blurred as we continue to invite nature into our homes, yet also begin to apply the 'rules' of home design to our outdoor areas - seeing these areas as an 'additional room' of our properties.

From patterned rugs and trendy cushions to decorative lighting or lounge chairs, the separation between furniture being suitable for sole indoor or outdoor use is diminishing. These versatile pieces are a great way of letting your personality spill into your outdoor lounging spaces, that feels just as cool and cosy as your interior.



Mediterranean Escapism

Mediterranean-inspired design is a key influence for the hottest garden design trends of the moment. Think refined, sophisticated style with a mix of tactile features and soft, warm neutrals in your paving tiles or furniture selections.

While sandstone or limestone paving provides an unmatched sense of traditional charm, antique effect porcelain tiles offer a result of engineered perfection: recreating the subtle tumbled edges and

antiqued surface of natural stone, combined with the practicality of modern porcelain.

For more of a contemporary take on these Mediterranean patio trends, break up large areas of expansive paving by interlaying gravel or grass between your slabs to create a smart, stepping-stone-style pathway that feels super chic.

www.stonesuperstore.co.uk

EXCEPTIONAL PRODUCTS | EXCEPTIONAL SERVICE | BESPOKE FABRICATION

Lux Unique design and manufacture bespoke high quality steel garden products in the UK.

The team behind Lux Unique are family and fabricate all their own products in Cheshire. They have a wealth of state-of-the-art machinery and expertise at their disposal and are very experienced in all aspects of steel fabrication and design. Over the last few years, the company has grown to support many garden designers and clients in creating bespoke pieces for their outside spaces which are beautifully designed and will stand the test of time.

The popularity of Cor-ten steel known for its exceptional strength, longevity and zero maintenance has seen this material become the product of choice for so many landscapers and garden designers. Lux Unique offer a minimum thickness of 3mm on all Cor-ten products because to offer a thinner material would simply compromise on the quality and strength of the product, something many of their competitors do.

The company also offers steels products in powder coated and galvanised finishes.

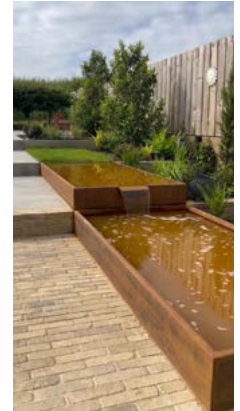

The in-house design team, technical engineers and fabricators mean that Lux Unique have total control over the design and manufacturing process from inception to completion and can work with clients to create truly bespoke, high quality crafted pieces.

The team has created many bespoke pieces for clients including planters, raised beds, water features, ponds, steps, and garden edging, working with designers on all the technical aspects of

their ideas to come up with solutions to suit the space and budget.

Its commitment to high standards has placed Lux Unique at the forefront of bespoke fabrication for the garden industry, bringing superior quality UK made products to the market and offering a personal one-to-one service for all its clients.

T: 03333 66 11 30

Email: hello@luxunique.co.uk

W: www.luxunique.co.uk

LUX UNIQUE

Bespoke Steel Garden Products

www.luxunique.co.uk
hello@luxunique.co.uk
 (t) 033 33 66 11 30

Planters | Ponds | Edging | Raised Beds

HOW NEXT-GENERATION TECHNOLOGY IS SHAPING LANDSCAPE AND URBAN DESIGN



Eric Gilbey, PLA Vectorworks Product Marketing Manager - Landscape

Eric Gilbey, PLA, uses his professional experience as a practicing landscape architect and his experience in CAD and BIM in his role as product marketing manager for the landscape industries at Vectorworks, Inc., where he continues to develop an understanding of design and visualisation workflows used by land planning and site design professionals. He is the immediate past president of the Association of Professional Landscape Designers and recently served as co-chair of ASLA's Digital Technology Professional Practice Network. Eric writes and speaks for several green industry associations and helps landscape architects and designers develop best practices, including sustainable site design and site-specific BIM. Eric received an Associate of Applied Science degree in Landscape Contracting

and Construction and a Bachelor of Science in Landscape Architecture from the Ohio State University.

In the ever-evolving landscape and urban design industry, technology is reshaping how professionals conceptualise, plan, and execute projects. Design software has become an essential asset for the industry as it offers many benefits, from bringing visions to life to increasing interoperability and project management. By leveraging design software, professionals can satisfy clients' needs, adhere to budget constraints, and meet time-sensitive deadlines with greater precision and ease. Additionally, collaborative features within these platforms facilitate smoother communication among designers, contractors, and other stakeholders, fostering a more cohesive and efficient workflow.

As the industry continues to evolve, designers must adapt to it. Luckily, software providers are staying up

to date on the latest developments. Vectorworks, for example, is a global design software provider made specifically for landscape architects and designers, allowing you to follow your imagination wherever it leads. So, it's important not to feel intimidated by technology but rather to see how it can boost your workflow and productivity like never before.

Technology can revolutionise landscape design for various scenarios, such as site inventory, a vital step for any site design project. A digital record of existing conditions gives you a helpful basis for design. And one of the groundbreaking technologies transforming landscape design is photogrammetry. This method utilises photographs to generate highly accurate 3D models of objects or spaces. In Vectorworks Landmark, you can capture multiple images from various angles; photogrammetry creates detailed and realistic representations of

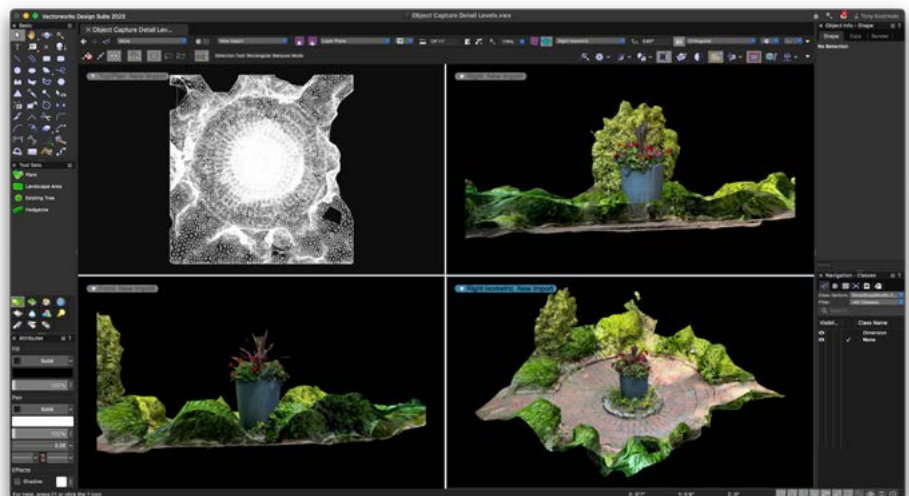

Photogrammetry allows you to use photographs to create 3D models of objects or spaces.

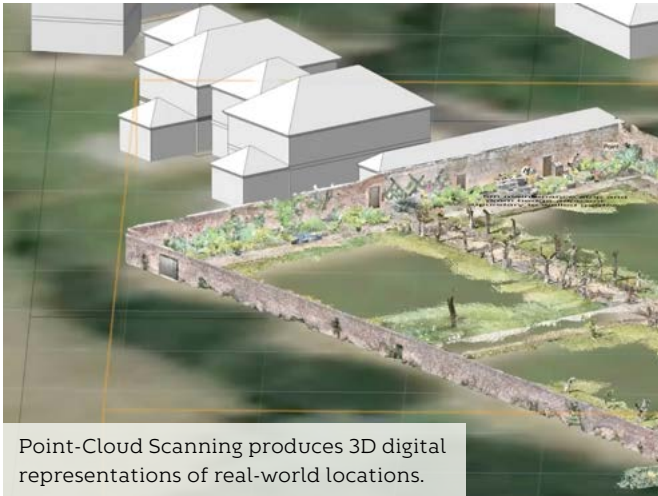

Point-Cloud Scanning produces 3D digital representations of real-world locations.

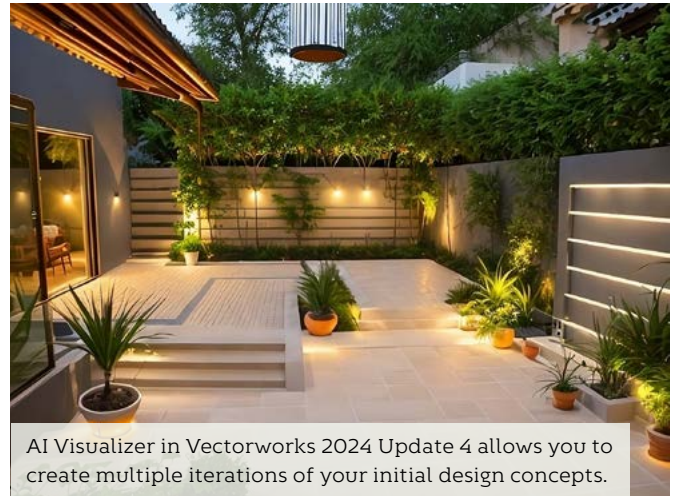

AI Visualizer in Vectorworks 2024 Update 4 allows you to create multiple iterations of your initial design concepts.

landscapes, enabling designers to visualise and manipulate the environment with unprecedented accuracy and fidelity. Taking it further, Vectorworks' mobile app, Nomad, available for iOS and Android, enables photogrammetry to capture objects from multiple angles. This allows users to physically walk around objects like boulders, trees, sculptures, furniture, and even people to capture detailed scans.

Similarly, point-cloud scanning has emerged as a powerful tool for capturing real-world locations in intricate detail. Using Light Detection and Ranging (LIDAR) technology, point-cloud scanning produces digital representations composed of thousands or millions of individual points, each with precise X, Y, and Z coordinates. These point clouds serve as invaluable references for designers, providing comprehensive data for site analysis, modelling, and visualisation.

It's no secret that artificial intelligence (AI) is becoming more prevalent and valuable, propelling the landscape design process into a new era of efficiency, creativity, and collaboration. We recently released Vectorworks 2024 Update 4, which introduced the AI Visualizer that allows designers to harness the computational power of AI to quickly generate illustrative concepts or refine images using their Vectorworks models. This feature, powered by Stable Diffusion and seamlessly integrated with Vectorworks Cloud Services, empowers designers to ideate and iterate with unprecedented speed and ease, enhancing the design process at every stage.

Virtual reality (VR) technology is another game-changer in landscape design, offering immersive experiences that transcend traditional visualisation methods. With tools like Vectorworks Odyssey, a VR viewer app designed for Meta Quest headsets, designers can

explore their projects in immersive VR environments, gaining valuable insights and perspectives. From bird's-eye views to interactive walkthroughs, VR technology enables designers to immerse themselves in their creations, facilitating better context and more informed decision-making.

Moreover, VR design tools enhance workflow efficiency and facilitate client engagement and communication. By inviting clients to experience their projects in VR, designers can foster a deeper understanding and appreciation for the design vision, effectively conveying concepts and eliciting feedback more intuitively and impactfully.

Next-generation technology is transforming landscape and urban design, empowering professionals with innovative tools and capabilities to push the boundaries of creativity and efficiency. From AI-powered design software to photogrammetry, point-cloud scanning, and virtual reality, these advancements are reshaping the landscape design process, enabling designers to visualise, communicate, and execute their ideas with unprecedented precision and effectiveness. As technology develops, the future of landscape design holds limitless possibilities, promising to elevate the built environment and enrich the lives of communities worldwide. Vectorworks Landmark strives to remain at the forefront of innovation, empowering designers to shape a more sustainable, inclusive, and inspiring environment.



Vectorworks Odyssey allows you to experience early and schematic designs in virtual reality.



INTRODUCING THE COTSWOLD COMPANY GARDEN FURNITURE COLLECTIONS FOR SUMMER 2024



For Summer 2024, The Cotswold Company presents a beautifully curated collection of outdoor furniture. Renowned for their beautifully crafted and timeless furniture and home accessories inspired by the beauty and nature of the Cotswolds. This year, in response to popular demand, a number of new outdoor furniture styles have been introduced to the range, all crafted using the finest materials such as sustainably sourced acacia wood, hand-woven rattan, and luxurious showerproof material for cushions and seat pads.

Lisa Coppin, Chief Creative Officer at The Cotswold Company, says, 'At The Cotswold Company, we appreciate the rhythms of nature and how the changing seasons can refresh our spirits and living spaces. Our new outdoor furniture collections have been thoughtfully chosen to enhance those special alfresco celebrations with family and friends. Carefully considered and meticulously crafted, our outdoor collections incorporate a range of styles suitable for both traditional cottage gardens and contemporary city dwellings.'

Indulge in luxury with the Chedworth rattan garden lounge set, hand-woven to perfection. This traditional ensemble comprises a spacious three-seater sofa, two armchairs, and a coffee table, offering the ideal setting for gatherings. Whether placed in conservatories or larger outdoor spaces, the showerproof cushions ensure enduring comfort.



ENVIRONMENTAL AND CLIMATE CONSIDERATIONS IN GARDEN DESIGN: BUILDING SUSTAINABLE GREEN SPACES FOR THE FUTURE



In an era marked by rapidly changing environmental conditions and growing concerns over climate change, the need to consider environmental and climate factors in garden design has never been more crucial. Gardens, in both urban and rural locations, play a pivotal role in fostering biodiversity, mitigating environmental degradation, and promoting resilience against climate fluctuations.

Rising temperatures, erratic weather patterns, and extreme events pose significant challenges to garden and landscape designers.



In response to these challenges, designers must seek to prioritise resilience and sustainability through a diverse range of solutions. For example, selecting plant species that are resilient to heat, drought, and flooding; in response to both increasing temperatures and unpredictable precipitation. Further, implementing irrigation systems that seek to manage water more effectively and utilizing permeable paving materials to mitigate stormwater runoff helps to better manage water use and better maintain soil moisture and stabilise the water table.

If you are considering a career in Garden Design, West Dean's Diploma in Garden Design is a uniquely designed to prepare students for a career in the industry. This one-year course follows the growing year and combines practical gardening skills, hard landscaping, plant science and creative design principles in a part-time format to provide you with

the skills and knowledge required to embark on a career in Garden Design.

West Dean also offers a series of short courses that can start you on your garden design journey and help you think about the climate and environmental issues you should consider when designing your own garden. Creating a Drought Tolerant Garden (4 July) will introduce you to a range of drought tolerant perennials pollinator-friendly plants and the use of recycled materials as a mulch to retain moisture and provide a low fertility layer. While Organic, Low Carbon and Sustainable Gardening (13 October) will offer insights into organic and permaculture principles that will enable you to design beautiful, resilient, and carbon absorbing gardens.



Find a course and be inspired at westdean.ac.uk

MAKE YOUR MARK

Master the creative and practical skills needed to launch your own garden design business.

- Industry-recognised Diploma qualification
- One year, part-time, practical course

Learn the principles of garden design, business, landscaping, horticulture and plant science from expert tutors with extensive industry connections.

Find out more and be inspired at westdean.ac.uk



TAKE OUTDOOR GRILLING AND ENTERTAINING TO THE NEXT LEVEL WITH CABINEX OUTDOOR KITCHENS



Award winning outdoor kitchens of distinction, Cabinex has been the choice for outdoor cooking enthusiasts around the world for almost 15 years. It is a unique modular system that is suitable for DIY projects and provides a sleek and modern outdoor kitchen for architects, designers, developers, and landscapers.

These kitchens are produced and engineered to give you the highest

performance and durability that an outdoor kitchen needs as well as being versatile and well equipped, creating that dream grilling oasis. They have been developed to withstand the harshest of outdoor weather conditions with all components being constructed from Weathercraft panelling and a patented aluminium framing system to form a rigid and robust cabinetry solution, ready for years of outdoor entertaining.



Available in a classic or a premium version along with a new PRO range where you can explore the possibilities of a customised kitchen using corner and Kamado modules, which enable different layouts such as L-shape or U-shape. These high-end kitchens have clever storage solutions, plenty of worktop space and seamlessly blends technology, design, and versatility. These kitchens include a 108-litre bar fridge, 4, 5 or 6 burner BeefEater barbecue and a matt black sink and mixer tap that is WRAS certified.

Cabinex is proudly partnered with the iconic Australian barbecue brand BeefEater who have been at the forefront of the outdoor cooking market for over 30 years. BeefEater barbecues are constructed from high grade materials and have many unparalleled features to offer that will effortlessly elevate your culinary experience. Combined with the Cabinex outdoor kitchens, you really have the perfect set up for that ultimate outdoor cooking experience.

To help you get the perfect set up, there is an online app where you can design your outdoor kitchen yourself by selecting the modules, appliances, colours, and BeefEater barbecue then view it in your desired space using augmented reality. The possibilities are endless making sure your space is utilised, so you have that optimal cooking and alfresco spot that will take centre stage in your garden.

www.cabinex.co.uk



OUTDOOR KITCHENS OF DISTINCTION



- LUXURY OUTDOOR KITCHENS
- PARTNERED WITH THE ICONIC BEEFEATER BBQ'S
- QUALITY MATERIALS
- BESPOKE DESIGNS
- MODULAR CONFIGURATION
- VARIETY OF APPLIANCES AND CABINETS OPTIONS
- VIEW IN YOUR SPACE WITH AUGMENTED REALITY
- DIY PROJECT OR ASSEMBLY SERVICE AVAILABLE



FOLLOW US...

- Cabinex.co.uk
- [Cabinex.europe](https://www.instagram.com/Cabinex.europe)
- [Beefeaterbbqeuropa](https://www.facebook.com/Beefeaterbbqeuropa)



BeefEater Europe
 PO Box 1238
 Cheddar
 BS27 9AH
 United Kingdom

Phone +44 (0) 1934 743322
 Email sales@beefeateureurope.co.uk



BEAUTIFUL POTS AND PLANTERS

Torc make everything from their studio in the British Isles creating beautiful pots and planters to enhance any outdoor (or indoor) space.

Working alongside a talented team of artisans this family run business really specializes in textures, scale and especially bespoke design. Their pots are shaped by hand until they take on their own unique form - no two pots are ever quite the same. When we are surrounded by so much that is mass produced Torc

believe there is a real appreciation for hand-crafted objects.

The design side of their business is getting busier all the time with landscape architects and garden designers alike realizing just how much expertise this company has to offer with a wealth of experience in design and problem solving to bring to the table. Torc welcome the opportunity to be involved at the design stage and are happy to contribute ideas when requested. Frequently being commissioned to

provide planter designs and outdoor furniture as a one-off template for both commercial and residential spaces.

Launching their new contemporary shaped water bowl this month was a good example of how far they can go - the diameter of this piece can be offered up to 3m wide. Their green credentials are pretty impressive too.

www.torc pots.com

TORC:POTS





DAVAL FURNITURE

Daval Furniture was recently commissioned to design the kitchen and interior for a luxury garden room in West Yorkshire, working alongside oak frame specialist, Paragon Oak. Creative director, James Bodsworth, shares the story of the project.

“The client’s impressive eight-bedroom home is a stunning example of Georgian architecture set in beautiful grounds. Boasting an impactful reception hall, drawing

room, library and kitchen among other spaces, the interior of the house is truly impressive. Equally impressive are the expansive grounds and surrounding gardens in which the house is set. Daval was commissioned to help the client bring to life a new summer house built from oak by Huddersfield experts, Paragon Oak.

“With the oak structure of the summer house nearing completion, the client tasked us with designing

a kitchen that would compliment the open, airy garden room Paragon Oak had designed and built in their grounds. The brief was fairly open, and we were given the freedom to lead on the design and colour palette for the space.

“Keeping the light, airy feel of more traditional summer houses, we designed the space with minimal, Scandinavian design cues taking the lead. Keeping the kitchen cabinetry to a neutral palette, we specified

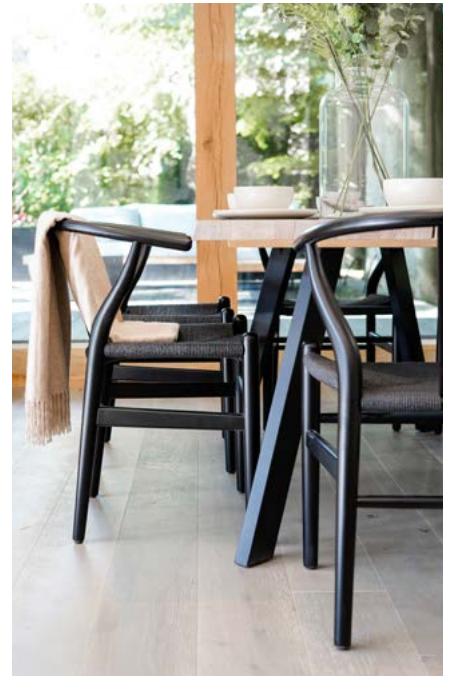

our Mayfair collection in Talpa for this project. Black knurled bar and knob handles were used to add a subtle industrial aesthetic to the kitchen, and we added a bespoke-made shelving unit to match, ideal for displaying glass jars, cooking oils, flowers and trinkets. A Quooker Pro 3 Fusion tap in matt black finished the look and supplies the garden room kitchen with instant boiling water.

“Our client also asked us to specify the furniture for the space to ensure continuity of the Scandi aesthetic, which saw us source wishbone dining chairs with black woven seats, and a stunning whitewashed oak dining table, perfect for hosting fun summer lunches and cosy winter feasts.

“The Hall Gardens luxury garden room is a unique project at a stunning property. The space works beautifully in both summer and winter, and the kitchen makes the space fully self-contained to allow the client to entertain all day long and all year round, without needing to make trips back and forth to the main house.

“The simple yet elegant design of our Mayfair cabinetry lends itself superbly to this project, as it defines the kitchen space with a subtle use of muted colour, while at the same time letting the kitchen exist in the background while the stunning oak framing takes centre stage.”



Website: daval-furniture.co.uk

COMBINE FUNCTIONALITY AND STYLE INTO YOUR GARDEN:

INTRODUCING THE 2024 GARDENHOUSE24 MODELS

Gardenhouse24 is delighted to introduce their new 2024 models including log houses, garden rooms, sheds, wooden garages, saunas and more. Having been in the British market for over a decade we pride ourselves on delivering superior craftsmanship at unbeatable prices. The new features and upgraded designs of our luxurious cabins marries both style and functionality. Whether you are looking to add more storage space, a home office or leisure room, the possibilities are endless.

In the dynamic landscape of contemporary living, Gardenhouse24 recognises the trends that are reshaping the way we live and work. Our versatile garden rooms can be customized to reflect your personality and lifestyle preferences to create a space that is truly yours. With their natural wood finish and sleek modern design our garden rooms blend seamlessly with any outdoor landscape. Our 2024 models can be easily customised to suit your needs. Many of our customers choose to purchase a garden room for the purpose of a home office or personal gym.

Home Offices

Remote working has significantly increased in recent years and comes with many advantages however, many do not have the space to comfortably work from home. By installing a home office in your garden, it establishes a dedicated space to work which will significantly improve individuals work-life balance, productivity and creativity.

Top picks for your new home office:

- Astel Garden Office Box
- Garden Room Mia 28

Home Gym

Recognising the importance of health and fitness, many homeowners now have a dedicated space in their homes to get their gym session in. Home gyms have never been so appealing, they offer convenience for those who want to get a quick workout completed, privacy for those who find crowded gyms intimidating and customisation to choose equipment they enjoy using tailored to their fitness goals.

Top picks for your new home gym:

- Garden Room Kubi 44
- Garden Room Cube B

We've been in the British market for over a decade, and with our speedy delivery, we can turn your ideas into a high-quality garden room in record time.

We strive for perfection in everything we do. That is why our luxury garden units are made from the highest quality materials. Our secret ingredient, slow-growing Nordic timber is durable and



designed to stand the test of time allowing you to enjoy your cabin for years to come. We've been in the British market for over a decade, and with our speedy delivery, we can install your high-quality garden room in record time.



Ready to transform your outdoor space?

Contact us today:

www.gardenhouse24.co.uk

Email: info@gardenhouse24.co.uk

Tel: 020 3728 8814

Or visit our display village:

Downtown Garden Centre,

Gonerby Moor, Grantham, NG32 2AB



Gardenhouse24.co.uk

TIMBER GARDEN PRODUCTS

MAKE YOUR DREAM GARDEN A REALITY with Gardenhouse24

Garden rooms, saunas, hot tubs and more



Choose Gardenhouse24 for unparalleled variety, product quality and expertise.

Our extensive range of garden houses, saunas, sheds, garages, and home offices caters to both private customers and business clients alike. Whether you're looking for a cozy backyard retreat or a functional workspace, our diverse collection has you covered.

Unlock Unbeatable Savings Today!

3% discount* on all upfront payments and special offers for landscaping companies

www.gardenhouse24.co.uk

Email: info@gardenhouse24.co.uk • **Tel:** 020 3728 8814

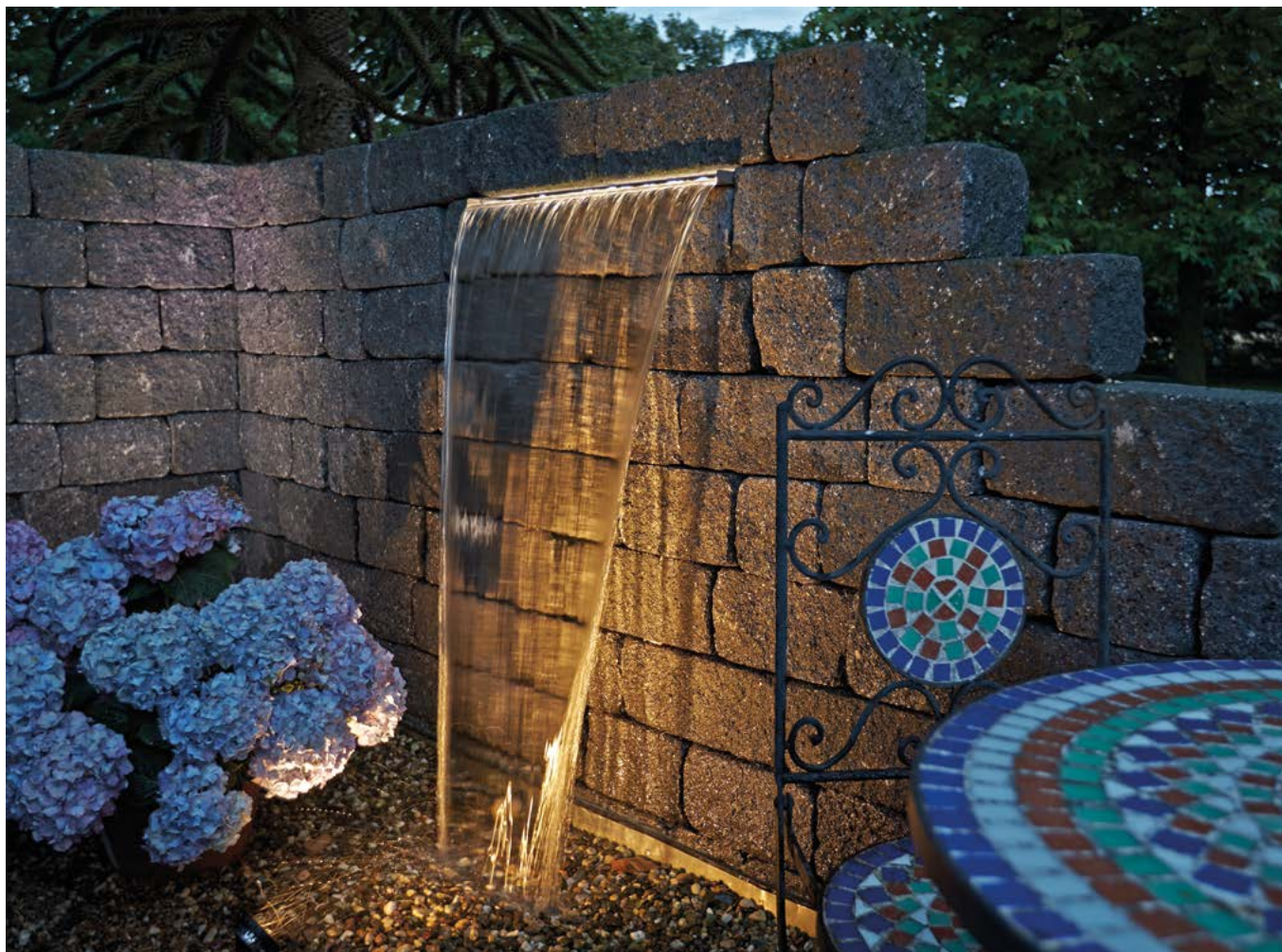

A PASSION FOR WATER

OASE don't just make the inspiring water features that you see on the opposite page. Did you know they make all the technical equipment to keep things running too?

Starting as an agricultural pump manufacturer back in the 1950s OASE has developed over the past 70 years as a leading pump producer in the aquatics industry. With German engineering behind every product, you know you're installing something of quality.



The pump is the beating heart of any water feature. When working out which size you need, you start by measuring the overall height of the feature. If you know what flow rate is recommended, you can use pump performance curves to find the right pump size for you. OASE Water Garden pumps come in various sizes from 2500 up-to 44,000 l/h. Furthermore, pipe size and inlet/outlet size can be changed to suit your feature's requirements.

The only way to create the perfect waterfall feature is to choose the right pump. To achieve a full sheet of water and not a 'V'-shape, you will need to calculate how high the drop of the blade is. The higher it is, the more flow is needed.

To specifically create the waterfall effect shown here, a 1-metre-wide blade dropping 1 metre into a pond requires 300 litres per minute flow



rate. That's 18,000 LPH to maintain a full sheet of water effect. Don't forget that taking head loss into account, you will require a pump larger than an 18,000 model to give you 18,000 LPH at the 1m head height.

At OASE we have a dedicated technical team that will help assist you in selecting the correct pump. We never want you to feel overwhelmed or confused and so we are here to help!

Get in touch with our team on enquiries@oase.com or give us a call on 01256 896886

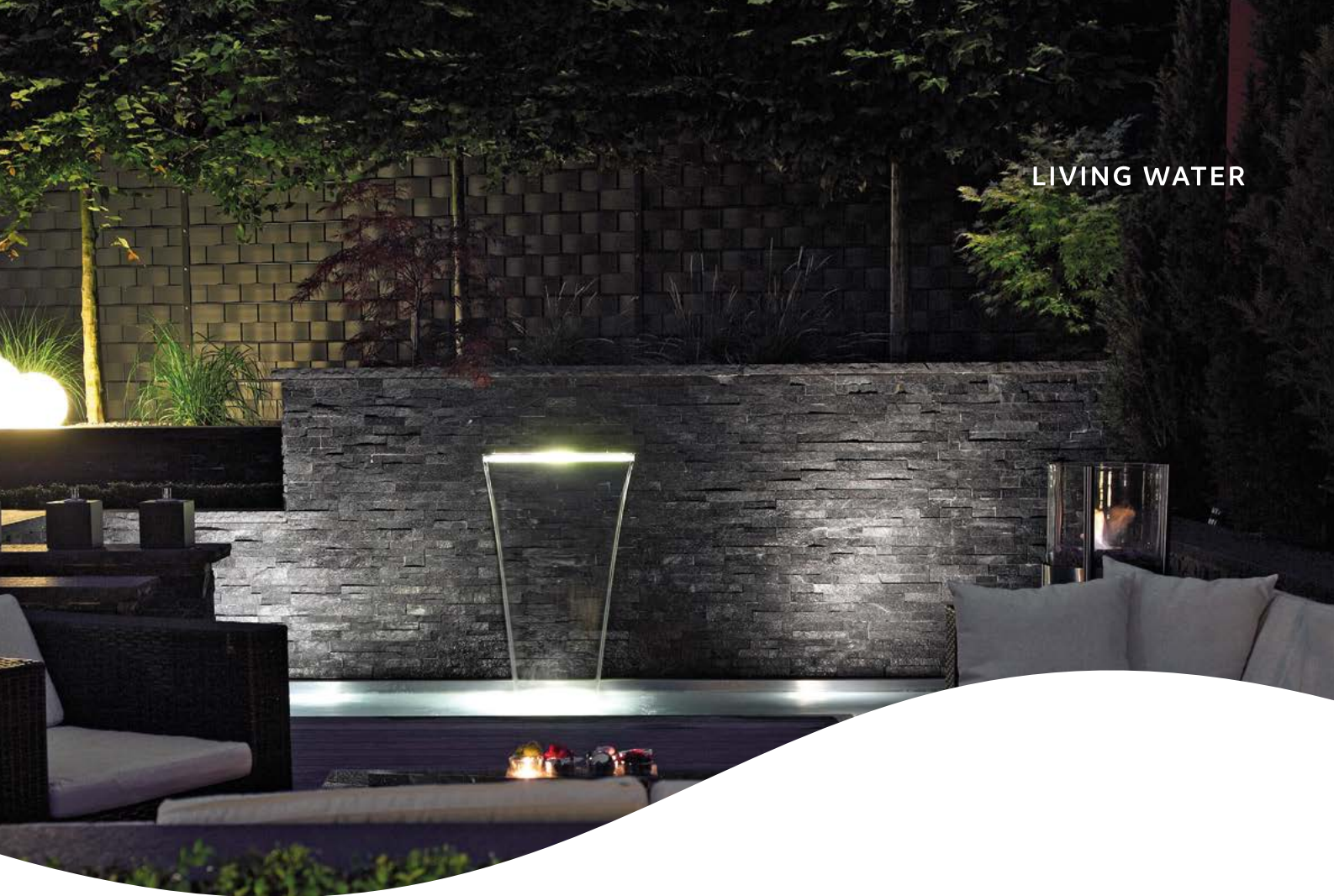

Create the perfect space for relaxation

WITH OASE WATERFALLS

Whatever space you have to work with, adding moving water always improves the sense of relaxation. And you can create the perfect atmosphere using OASE's stainless steel waterfalls.

With three sizes of waterfall available (30, 60 and 90 cm) you can be sure there's one that will fit in the space you have available. They come with a threaded hosetail and can be recessed into a wall or screwed onto it.

If you're not working with a pool or a pond, you can use OASE's self-contained reservoirs. These mean you don't need to worry about open water. The pump and all the technology are hidden away meaning your water feature can be enjoyed from any angle.

All OASE features are available with optional LED lighting to ensure the space looks great at any time of the day or night.

OASE makes all the equipment needed to keep these features running, including energy efficient pumps with high quality German engineering. Find OASE technology, including Waterfalls at your local retailer today.



Discover more at
www.oase.com

Oase



INTRODUCING THE HEX FROM THE ULTIMATE SPACE COMPANY

Introducing 'The Hex' - a unique, hexagonal office, studio, library, consultation room or simply 'your sanctuary' that doesn't require planning permission, fits even the smallest gardens or outside spaces and can move with you.

2021 transformed the world of work, with remote/agile/flexible working here to stay due to the clear benefits in terms of increased productivity, reduced commute time and costs, plus better work-life balance.

BUT there is an issue: the kitchen table, sofa, bed or ironing board

were not designed for working on, meaning 73% of those working from home do not have a dedicated workspace!

The Ultimate Space Company, founded by Chris, Jamie and John, was born out of a need to help humans navigate through this historic transition.

As an employer you want your staff to be as productive at home, as they are in the office. As an employee, you want to find the perfect work-life balance, where productivity and well-being merge.

The Hex is a space that works for You.

Distractions, frustrations, feeling unproductive? We understand it all.

We created the Hex as we believe that everyone deserves the space to reach their full potential. Your space has never been so critical. To you.

Months of meticulous design and planning by the team at Astheimer lead to a design that maximised the most optimum space, for the smallest footprint.



The hex is the most efficient space, that results in the most efficient work. A space for you to get the most out of your day.

We are on a journey and will continue to raise the bar. To try and achieve the very best, the very 'ultimate' of spaces.

Truly Customisable

With more than 2,000 external and internal colour and flooring options, your Hex can be as unique as you are. So, whether you want your Hex to blend into the garden or you want to make a bold statement, the choice is yours.

50-Year Lifespan = Ultimate Sustainability

The Hex's unique design and aluminium construction ensures generations will study, work and enjoy their Hex, even moving it from home to home as life evolves.

Ready-to-Use

Supplied with movable shelving, power, USB chargers and dimmable lighting.



 Height: 2.5m	 Width: 2.1m	 Length: 1.9m	 2.34m ² Floorspace	 Easily Transportable
 Insulated with Quadcore®	 Wifi Compatible	 Natural Light	 Secure Locking	 Planning Approved

www.ultimatespacecompany.co.uk

EXPERTS TACKLE 'GIANT DROP' TO BUILD 'STUNNING' HOME OFFICE FOR NEW DAD



and the only access to the garden is through our Edwardian house with some very narrow doorways.

"Then once they had gotten to the garden they had to work over a giant drop at the back where my neighbours had recently excavated a deep basement.

"To top all of this off we only had two-and-a-half months from when we started before our baby was due.

In the heart of South London, nestled among the bustling terraced townhouses where space is a coveted luxury, a new dad found himself faced with a dilemma.

Billy's once serene bedroom, which doubled as a workspace, was to undergo a transformation into the nursery for his newborn.

Undeterred, the 32-year-old marketing director sought a solution that would not only maintain his productivity but also offer a sanctuary amidst the chaos of family life.

Expert installers from Elite Garden Studios built the 3x4.5m home office within just two weeks in a race against time before the baby arrived.

This was achieved despite having to overcome a series of challenges including parking restrictions, being forced to carry the materials through the front door and down a flight of stairs then another 40ft to the garden.

Billy said: "We live in a very busy area just out of central London, on a bus lane, with no nearby parking

"EGS were amazing at adapting and moved heaven and earth to deliver on time."

It comes as EGS was last month awarded the title of the 'most thermally efficient garden room in the UK' by independent engineering consultants.

Analysis showed its garden rooms excel in thermal performance, with a U-value of 0.16 W/m²K, surpassing industry standards for insulation.

EGS's low U-Value and condensation-free build protects the structure and longevity of the room and reduces energy bills and the carbon footprint for its customers.

Meanwhile, homeowner Billy has installed a desk, TV and sofa in the amazing studio, and turned it into the perfect work space all year round.

He hailed the 'incredible service' provided by EGS and said the room heats up in just five minutes, even in the winter and the insulation is 'better than my house'.



Billy added: "Elite Garden Studios turned my garden into a functional and stunning home office. The quality of construction is top-notch!"

"Even in colder months, the heating system warms up the space in just five minutes. The skilled team overcame London challenges with professionalism and the project manager made the process stress-free. His design suggestions were spot-on.

"To top all of this off, we only had two-and-a-half months from when we started before our baby was due and the project had to be completed before this time.

"I highly recommend Elite Garden Studios for their quality construction, design, insulation and exceptional professionalism. Thrilled with the result!"

Matt Forrest, Managing Director of EGS, said: "We're thrilled with our latest award as it confirms our commitment to leveraging cutting-edge materials and construction methods to deliver spaces that are not only beautiful but also scientifically sound."

FOUR OAKS CASH & CARRY



Ensure that your customers garden stays bustling and brimming with blooms during the spring and summer months with our selection of flowering plants. From firm British favourites to more exotic species, our summer flowering plants category casts a wide net, providing the best varieties with the greatest growing characteristics.

Four Oaks Cash & Carry Trade Plant Nursery has been a family-owned business for over 50 years, serving the country with high-quality plants and garden supplies from all over the world. Our passion for gardening has been passed down through generations, and we are proud to continue providing exceptional service to our

customers. Four Oaks continue to provide fresh and interesting seasonal, value added range of pots and baskets made onsite on throughout the year.

Now offering over 1500 lines of trees and shrubs, which will be on display from starter plants to specimen sizes. We have a special range of plants from Italy and Spain, including masterpiece bonsai trees and sculpture plants for that finishing touch on a garden project. We have a wide range of sundries also available, including garden furniture, compost, pots and planters of all sizes, gardening tools and many more.

Offering all year-round shrub and specimen nursery stock for commercial and amenity landscaping along with garden centre sales, with one of the widest ranges in the Northwest. Come and visit the largest horticultural "one stop shop" in the UK, located just 5 miles from junction 18 of the M6 motorway, or visit our website below for further information.

Tel: +44 (0) 477 571 797
marlon@fouroaks-nurseries.co.uk
www.fouroaks-nurseries.com



Four Oaks
Cash & Carry

Longshoot Road, Lower Withington, Macclesfield, Cheshire SK11 9DX



The largest horticultural "One Stop Shop" in the UK

Specimens trees - compost - pots and sundries

www.fouroaks-nurseries.com / marlon@fouroaks-nurseries.co.uk / Tel: +44 (0) 1477 571 797

BIRKDALE'S DURAPOST® PRIMA COMPOSITE BOARD IS NOW MADE FROM 70% RECYCLED MATERIALS



Manufactured in the UK, the DuraPost® Prima Composite Board now features a recycled PVCu core, meaning installers can help their customers to achieve an overall more sustainable fencing solution. Available in lengths of 1.83m and 2.44m, it is compatible with any DuraPost® or concrete fence post installation and due to its lightweight, it is extremely easy to work with and install.

The DuraPost® Prima Composite Board can be used as a gravel board, designed to provide an added level of protection at the base of a fence installation, or stacked to create a sleek and stylish, splinter-free full fence panel. With a tongue and groove connection for complete privacy and safety, the gravel

board offers incredible strength over alternative panelling systems for a longer lasting solution. Now manufactured using a recycled PVCu core, the DuraPost® Prima Composite Board is made from 70% recycled plastic with a virgin PVCu skin.

John Abernethie, Managing Director at Birkdale, commented: "Our goal is to make sustainable gate and fencing solutions that have low environmental impact, while still delivering the best products. This update to our DuraPost® Prima Composite Board is in line with that ambition. Installers can rest assured when selecting Birkdale products that we are an environmentally conscious supplier - providing EPDs for DuraPost® fence posts, composite

panels made from rice husks and recycled plastic, and we are a carbon neutral company."

The DuraPost® Prima Composite Board is available in a range of colours including Anthracite Grey, Olive Grey, Sepia Brown and Black, ensuring it can complement any post and panel combination. Furthermore, thanks to its PVCu structure, it is resistant to mould and rot, maintaining its traditional timber-look finish, whilst remaining incredibly low maintenance.

For further information about Birkdale, please visit www.birkdalesales.com

LOOKING FOR INSTANTLY STUNNING AND MATURE HEDGING?

Our ready to plant hedging is fully mature and perfectly knitted together, designed to give your outdoor space an instant transformation. The team at Readyhedge are passionate horticulturalists, with a passion for growing beautiful hedgerows.

Every year we grow over 40km of hedges in over 35 different varieties. Including individual plants, low and high panels, and screens. Our range of instant hedging is suitable for all garden types, both commercial and domestic.

Wide variety of hedges

Discover the large selection of evergreen, deciduous and mixed native hedging available. There are quick growing hedges, semi evergreen, formal hedges, and even low maintenance hedges to choose from!

Our aim is to fulfil orders in 48 hours, we offer secure and punctual delivery to any location within the country.

For more information contact Readyhedge on 01386 750585 or visit www.readyhedge.co.uk

Follow us on Social Media:

Facebook @Readyhedge

Twitter @Readyhedge

Instagram @readyhedge



**THE ORIGINAL
HEDGE IN A BAG**
FROM THE HOME OF
INSTANT HEDGING



READYHEDGE

Readyhedge hedging plants, like the mixed native hedging shown here, are container-grown in the UK and fully acclimatised to UK conditions. With over 20 years' experience, Readyhedge delivers hedging to rely on, wherever you are.

01386 750 585

info@readyhedge.com

readyhedge.com

TREE RELOCATION: PRESERVING NATURE'S BEAUTY FOR FUTURE GENERATIONS



Since 1963, Civic Trees have been at the forefront of tree relocation throughout the UK, from importing the very first Vermeer tree spade into Europe, to designing and constructing the Newman Frame which is now used worldwide.

Civic Trees are always looking to pioneer new techniques that aid the relocation of trees.

Tree relocation is a concept that involves uprooting trees from one location and transplanting them to another. With current events surrounding environmental issues, relocating trees is even more important now than ever before. By relocating trees instead of cutting them down, we can preserve nature's beauty while also promoting sustainability.

We are proud of our reputation for efficient, cost effective and reliable tree relocation throughout the UK. You can be confident that through our exemplary commitment to staff



training and development, our work meets the highest technical and safety standards.

We believe that a tree is only as good as the way it is handled, planted and maintained. Ground preparation and aftercare are crucial to the successful establishment of the tree.

Before we start the tree move process we arrange a site visit with our client and assess the tree's health, size, and root system. We also create a site specific risk assessment to ensure the whole operation is carried out safely.

Our team of experts use specialised equipment to excavate the tree with minimal damage to its root structure. The tree is then carefully transported to its new location,

where it is replanted and nurtured to ensure its successful adaptation.

Our experienced team will know and understand the benefits and methods of loading and unloading a tree using the correct lifting techniques in order not to stress the tree or root ball. This is imperative for the longevity of the tree's life.

In conclusion, tree relocation is an environmentally friendly method that allows us to preserve nature's beauty while supporting urban growth. By carefully uprooting and relocating trees, we can maintain the valuable benefits they provide to our communities.

Civic Trees prides itself in paying great attention to the health and well being of our clients most prized asset "THE TREE".



Supply. Plant. Relocate.



Visit: www.civictrees.co.uk
Email: info@civictrees.co.uk
Tel: 0208 950 4491





UNLOCK THE NATURAL BEAUTY OF WOOD

Our love for wood dates back centuries when our ancestors used the material to create not only tools but also sophisticated wooden structures. This passion for wood has never gone away as we still see it being used all around us daily in everything from decking, garden furniture and garden buildings.

Osmo are wood product specialists and with over 140 years of expertise and knowledge we have developed our own natural wood finishes. Osmo knows what it comes down to in terms of wood products and finishes.

New Osmo Garden Furniture Oil is made up of a combination of sunflower oil, thistle oil, soya oil and hard waxes. These natural ingredients work in harmony with the wood bringing out the full character and emphasising its grain and colour. The product provides a satin finish which enhances the woods natural beauty.

With its clear oil-based finish it is suitable for all wood in outdoor areas. The finish is extremely water-repellent, weatherproof and UV stable. The dry finish is also safe to humans, animals, and plants.

As well as enhancing the natural look of exterior wood the Osmo Garden Furniture Oil also has many other benefits:

High Coverage - With just one tin of Osmo, you can achieve near to double the square meter coverage of an ordinary finishing system, saving you time and money.

Natural Ingredients - The foundation of Osmo wood finishes has been based upon purified and refined natural resources which are carefully harvested natural oils and hard waxes.

No Sanding - Forget about time consuming, tiring sanding. Osmo

natural wood finishes can easily be renovated at any time without the need for sanding.

Microporous - The wood remains microporous and continues to absorb and release water without damage. This means that the finish will not peel, crack, or flake unlike other traditional finishes.

With Osmo you can be confident that your exterior wood will be looking great while being fully protected. Whether you're looking to start a new project renovate old and tired surfaces, Osmo has you covered with the perfect wood care product no matter the project.

Find out more at www.osmouk.com

Osmo, Good for Wood.

GARDEN FURNITURE OIL

osmo[®]

Unlock the natural colour and beauty of exterior wood



- Improves and maintains the appearance of wood
- Suitable for both hardwoods and softwoods
- Exceptionally high coverage
- Highly water and dirt resistant
- Microporous, penetrating finish, designed not to crack, peel or flake



Highly
Repellent



High
Coverage



Natural
Ingredients



Breathable

www.osmouk.com



ELEVATING OUTDOOR SPACES WITH EUROCELL GARDEN ROOMS

Home improvement specialist Eurocell, has launched three exciting new garden room styles, expanding its versatile range to meet the evolving demands of homeowners.

The new designs, Studio View, Studio Frame, and Studio Canopy, join the esteemed Studio One showcasing Eurocell's commitment to delivering premium-quality, sustainable and customisable outdoor spaces for homeowners who are looking for extra living space.

In addition to the fresh designs, Eurocell introduces a contemporary vertical flush cladding option, providing customers with an additional choice for the exterior finish. The sleek finish is available in the new Vertical Coastline range in Anthracite Grey, Moondust Grey, and Soft Green, or the vertical foiled wood effect cladding in Coriander, Anteaq, Truffle Oak, and Sheffield Concrete.

Garden rooms have become increasingly popular for their versatility, and Eurocell's new offerings cater to a variety of needs, from a creative space flooded with natural light to serve as a sanctuary for relaxation or entertaining, a location separate from the home that can serve as a home gym, a playroom for the family or a space to set-up and run a business from.

All models come equipped with an electric pack, panel heater and energy efficient, double-glazed doors and windows as a standard feature, ensuring they are ready to provide a warm and comfortable space throughout the year.

Sean Bunyan, Head of Commercial Operations and garden room specialist at Eurocell, said:

"We are excited to introduce these new garden room styles, reflecting our commitment to providing innovative solutions for outdoor living. Each design is crafted to meet the diverse needs of homeowners, offering a perfect blend of functionality and style."

The new releases also come with the assurance of Eurocell's dedication to sustainability. The Garden Rooms incorporate timber certified as sustainable by the Forest Stewardship Council (FSC), along with cladding made from 100% recyclable material.



Key features of the new garden room styles

Studio View

- Dual aspect doors for an optimal garden view.
- Ideal for garden enthusiasts, allowing natural light to flood the entire space.

Studio Frame

- Traditional garden room design with a modern twist.
- Contemporary front veranda for an additional outdoor space.

Studio Canopy

- Combines a garden room with a canopy for outdoor shelter.
- Perfect for creating a seating or dining area, extending the outdoor experience.

Sean added: "We believe in making home improvements easy and straightforward. Eurocell's Garden Rooms not only enhance outdoor living but also align with our commitment to sustainability, making them an excellent choice for homeowners."

If you're interested in becoming a Select Installer of Eurocell Garden Rooms, please get in touch
www.eurocell.co.uk/contact

HIGH QUALITY GAZEBOS AND SUMMER HOUSES



Bespoke Gazebos Ltd is a family run business offering high quality Summer Houses, Garden Rooms, Gazebos & Car Ports. Along side our Standard Structures we also offer a FREE survey service & design for Bespoke Structures. Offering shade from the sun and protection from the summer rain, our products are suitable for sheltering your garden furniture set to create an outdoor dining area, BBQ area & Bar. Our unique roof construction to support the stunning pyramid style roof with a flat line top to ensure no planning permission required. All are manufactured using the highest quality timber and pressure treated pine for longevity

www.bespoke-gazebos.co.uk
info@bespoke-gazebos.co.uk



NEW PLANTER ENHANCEMENT TRANSFORMATION

Amberol's New Planter Enhancement range has been designed to help transform old planters, as well as offering a new-look stylish planter and parklet, that integrates Amberol's popular self-watering Metre Square planter and Promenade planter.



The Friends of Ladybarn Park, is a local community group that is run by a group of volunteers that maintain and improve the park. They wanted to update some old planters with Amberol's New contemporary Planter Enhancement surrounds and they are thrilled with the results.

The New Planter Enhancement range is easy to install with easy-to-follow instructions to build from flat pack part-built materials. It is also made from high-quality materials including wood, recycled wood effect plastic, steel or dibond panels to feature graphics, logos or advertising. The panels are interconnected with a combination of roto moulded curved corners and T posts that can be manufactured from up to 100% recycled materials*.

*Subject to availability and MOQs.

FIND OUT MORE

For more information on Amberol's New Planter Enhancement range or to arrange a demo with Tim, please call 07795 251390, email tim.troman@amberol.co.uk or visit www.amberol.co.uk



Check TreeEbb.com for
Trees for bees



ebben.com | treeebb.com
Ebben nurseries



EBBEN
trees since 1862

RTF TURF IS THE NEW GENERATION OF TURF

RTF turf is a new generation of turf that has outstanding benefits from its drought tolerance, deep rooting capability to its high traffic tolerance and disease and insect resilience to name just a few. Inturf are pleased to announce that our new RTF turf will be available this summer and we are now taking a waiting list for requirements.



So, what does RTF mean? RTF stands for Rhizomatous Tall Fescue. Unlike traditional tall fescues, RTF offers unique advantages that result in a healthier, more vibrant turf. With its ability to quickly repair damaged areas and resist common issues like weed growth, RTF Turf stands out as a practical and effective solution for those seeking low-maintenance, high-quality grass.

RTF offers great tolerance to drought or waterlogged conditions through its deep rooting capability meaning less watering and greater adaptability to various soil conditions. Its extensive root system means it can repair damaged areas and fill bare spots with new shoots of grass providing a self-repairing turf.

RTF reduces the need for frequent overseeding and reduces the formation of unsightly clumps, giving you a consistently beautiful turf.

With its exceptional resilience, low maintenance requirements and environmental benefits RTF is suitable for certain sports grounds, professional landscaping, public gardens and open green spaces.

If RTF turf sounds of interest or you would like more information, then get in touch with the Inturf today and we can add you to the waiting list for this summer.

Call 01759 321000 or visit inturf.com



RTF Turf

Experience the future of turf with RTF turf.

From unmatched drought tolerance to rapid self-repair, our RTF turf delivers vibrant, low-maintenance grass for any landscape.

Join the waiting list for this summer with Inturf.

Tel: 01759 321000
Email: info@inturf.co.uk
Website: <https://inturf.com>

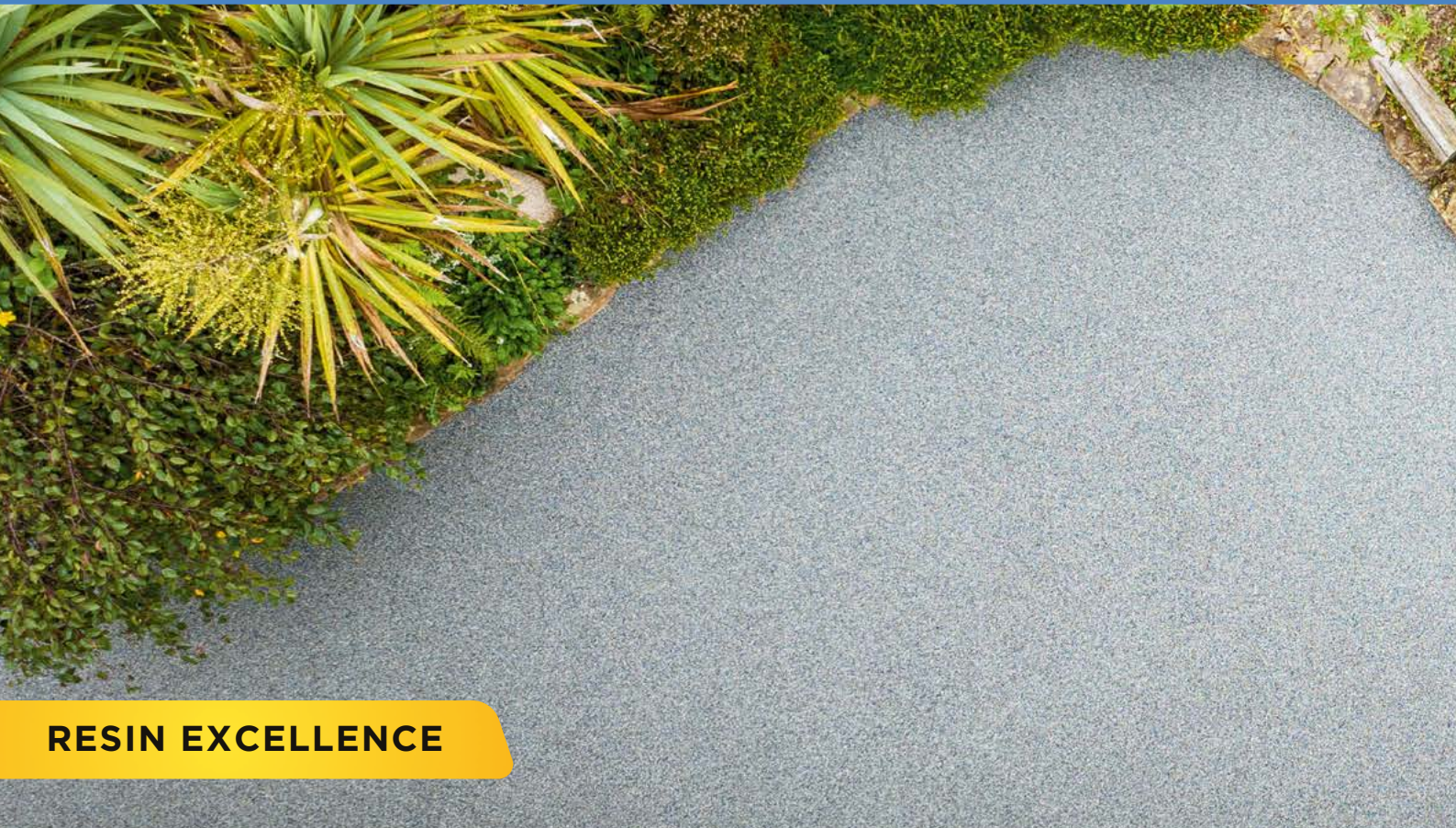

RESIN EXCELLENCE



'NO DIG' SOLUTIONS



BBA APPROVED

RESIN BOUND

Domestic & Commercial Solutions

Addagrip.co.uk

PERMEABLE RESIN BOUND PAVING SLABS



Resin bound paving has emerged as a revolutionary solution in the realm of urban landscaping, offering a marriage of durability, aesthetics, and eco-friendliness. Among the frontrunners in this innovative field is SUDwell, a company that has been spearheading the adoption of resin bound paving slabs. Their commitment to quality, sustainability, and versatility has not only transformed landscapes but also set a benchmark for the industry.

One of the most striking features of SUDwell resin bound paving slabs

is their durability. Constructed using a blend of high-quality resin and natural aggregates, these slabs boast exceptional strength and resilience. Unlike traditional paving materials that are prone to cracking and erosion over time, SUDwell resin bound paving slabs offer long-term stability, making them a cost-effective investment for both residential and commercial projects. This durability not only minimizes maintenance requirements but also ensures that the beauty of the paved surface endures for years to come.



Moreover, SUDwell's commitment to sustainability sets them apart in an industry often plagued by environmental concerns. By utilizing natural aggregates sourced from sustainable local suppliers and employing eco-friendly manufacturing processes, SUDwell minimizes its carbon footprint while maximizing the environmental benefits of resin bound paving. These slabs allow rainwater to permeate through the surface, reducing the risk of flooding and minimizing strain on drainage systems. This permeability also promotes groundwater recharge, contributing to the preservation of local ecosystems.

Beyond their practical benefits, SUDwell resin bound paving slabs offer unparalleled versatility in design. With a wide range of colors, textures, and patterns available, designers and homeowners alike have the freedom to unleash their creativity and customize their outdoor spaces to suit their unique preferences. Whether it's a sleek contemporary patio or a rustic garden pathway, SUDwell resin bound paving slabs provide the perfect canvas for bringing any vision to life.

In conclusion, SUDwell resin bound paving slabs represent a groundbreaking innovation in urban landscaping, offering a harmonious blend of durability, sustainability, and design versatility. As cities and communities worldwide seek sustainable solutions for their infrastructure needs, SUDwell stands as a shining example of how innovation can transform the urban landscape while preserving the planet for future generations.

theresinbondedslabcompany.co.uk

SUDwell™

The Resin Bonded Slab Company

UK #1 MANUFACTURER OF PERMEABLE RESIN BOUND PAVING SLABS

SUSTAINABLE URBAN DRAINAGE



- Save Time and Money
- Manufactured in the UK
- SuDS Compliant
- No Tarmac Needed
- No Concrete Needed
- Install the Same as Any Other Paver
- Light-weight - Easy to Handle
- No Cracking
- Easy to Cut
- No Pointing

Specify SUDwell™ For Your Next Project



Designed for durability and style, our slabs allow water to permeate through, preventing surface water buildup.

Choose from a variety of colors and textures to match your aesthetic.

Quick and easy installation ensures minimal disruption.

Transform your outdoor area with SUDwell – where beauty, functionality, and sustainability converge.



Use Discount Code: "LUD"
for 5% Off Your First Order

Driveways • Paths • Patios

Landscaping Sites

Heritage Sites

Pedestrian Precincts

Cycle Paths • Roads

Housing Developments

Retail Units

Town Centres

Also See Our Range of SuDS Rubber Paving



01424 830 494 • www.theresinbondedslabcompany.co.uk



ADDAGRIP'S COMMITMENT

At Addagrip, we are committed to enriching communities and fostering sustainable environments through our charitable initiatives. Our dedication extends beyond providing innovative surfacing solutions; we actively pursue opportunities to give back and make a meaningful impact. Each year, we support charitable projects that resonate with our core values of sustainability and corporate responsibility.

Transforming Landscape Mishaps into Sustainable Solutions with Stonebound

This charitable project was sparked by a discovery by Lewis from JHB Contractors—a poorly installed Resin Driveway and accompanying Pathway. The situation presented not just an eyesore but also a safety hazard for the family in question.

Technical Redemption and Sustainable Intervention

Our primary goal was not merely to replace but to revolutionise the existing installation with a sustainable approach. After the careful removal and eco-conscious disposal of the previous work, our team set the stage for a product we trust implicitly to perform in both form and function—Stonebound.

In Castle Grey, this Resin solution brings several benefits. It is resilient, maintaining its integrity under various conditions, and is revered for its permeability, a feature that contributes significantly to sustainable urban drainage systems (SUDS), ensuring that the installation is environmentally sound.

Collaboration: The Keystone of Success

Such a transformation, particularly in the charitable context that amplifies the essence of corporate social responsibility, is never a singular effort. It requires the skills, dedication, and resources of multiple entities, and this project saw indispensable contributions from several quarters.

1. JHB Contractors: The expertise that JHB Contractors brought to this venture cannot be overstated. They translated the technical



specifications of our Stonebound Resin into a flawlessly executed Resin Driveway and Pathway. Their precision, particularly under the observant eye of Lewis—who initially identified this opportunity—ensured the project met the meticulous standards that professionals in our industry demand.

2. Long Rake Spar: The aggregate was generously provided by Long Rake Spar. The quality of their material was integral, ensuring that the final look was as impressive as its structural integrity.

A Gesture of Gratitude

As Addagrip Terraco reflects on this project, we extend sincere thanks to JHB Contractors and Long Rake Spar. Their partnership was instrumental in turning a charitable cause into a showcase of excellence in landscape remediation. We also express our gratitude to Lewis from JHB, whose proactive approach in identifying this project underlines the significant impacts individuals can have within the larger industry framework.

Conclusion: Setting New Precedents

This endeavour transcends the act of installing a new driveway and pathway. It's about setting a precedent in our industry—demonstrating that quality,



sustainability, and charity can be intertwined beautifully and effectively. We showcased that remedial work doesn't just fix past mistakes but paves the way for innovative, sustainable standards in landscape design.

To our peers in architecture, building, and related sectors, we share this story as an affirmation of our commitment to quality and as an invitation to continue or initiate your contributions to similar causes. Through such projects, we do more than enhance our professional portfolio—we build a legacy of responsibility, sustainability, and collaborative success.



ELITE VERTI-CRETE

- MORE THAN JUST A FENCING SOLUTION

We all want to feel safe in our homes and communities, which is why safe, secure, low maintenance fencing is important within the built environment.

But so is the look of that fencing, as no one wants to feel a prisoner in their own environment.

Elite Precast Concrete has introduced their Elite Verti-Crete fencing and walling which, when installed, reduces and removes the opportunity for crime to occur in an environment and promotes a positive interaction between the space and legitimate users.

'Crime Prevention Through Environmental Design' (CPTED) aims to reduce both crime and the fear of crime, through urban design, site management and the use of the built environment, in order to prevent and reduce crime and the fear of crime and to promote and improve public health, quality of life and sustainability.

Elite's Verti-Crete secure fencing answers some of these needs by offering double-sided fence face options that all have security in mind.

When stakeholders are deciding on a fencing and walling solution, many take the following into consideration, either consciously or subconsciously.

Physical security - the measures which are used on individual dwellings to ensure that they withstand attack. Verti-Crete fencing and walling is made from precast concrete, providing strength and durability, making them ideal for security and privacy.

Movement control - the restriction of access, egress and through movement. Elite Verti-Crete is available in different heights, allowing movement to be controlled, reducing unwanted visitors.



Management and maintenance - the processes in place to ensure that a development is free from signs of disorder. Elite's fencing has an attractive finish on both sides, which gives a decorative look that looks good for years. This durable and low maintenance option can be used to frame the property, development or surrounding area, increasing value and pleasure to the area.

Defined space - clearly defining space between public, semi-public, semiprivate, and private areas. With different finishes and heights available, Elite Verti-Crete can be used to clearly define areas of use, while offering privacy.

Secure fencing - By installing a precast Fencing system, stakeholders benefit from security, sustainability, aesthetics, and an effective barrier to noise reduction and wind.

Installation - Elite Verti-Crete offers fast, easy installation and



can be used in conjunction with other products in the Elite Precast Concrete range, which include aesthetically pleasing walling, security barriers and bollards, all of which are manufactured to enhance the safety of people and infrastructure, making users feel secure and more confident in the places they spend their time in.

To find out more about the fencing system visit www.eliteprecast.co.uk, email sales@eliteprecast.co.uk or call 01952 588885



Verti-Crete Fencing & Walling System



Secure and Private



Effective Sound Barrier



Fast to Install

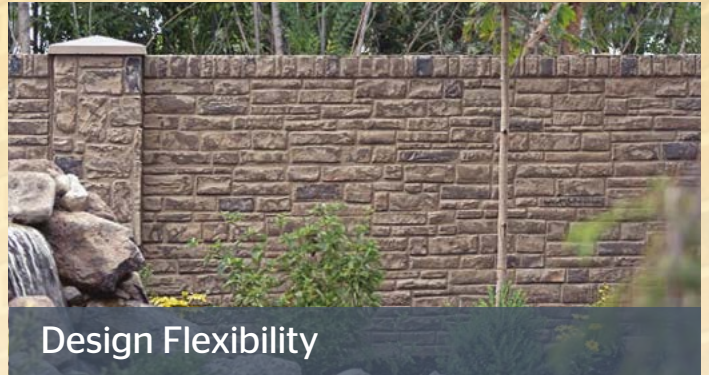

Design Flexibility



Cost Effective

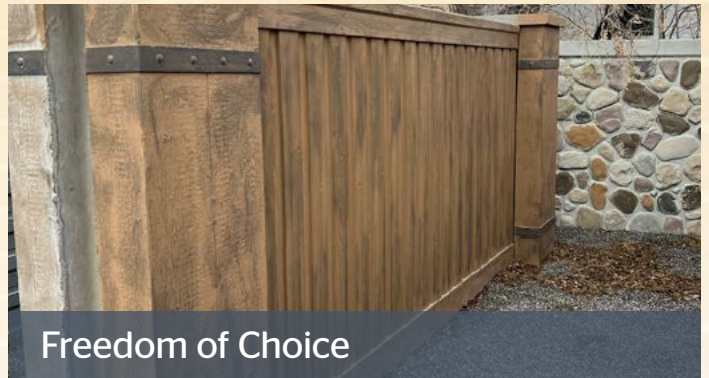

Freedom of Choice



Creating safer spaces with
fencing & walling solutions



For more information please call 01952 588 885
email sales@eliteprecast.co.uk or visit www.eliteprecast.co.uk

HILLS QUARRY PRODUCTS' CONTINUED EXPANSION



As a key part of The Hills Group, Hills Quarry Products has continued to build on its 120-year history with further expansion of its ready-mixed concrete business across the south of England. The last twelve months has seen Hills open new concrete plants in Swindon in Wiltshire and Wilmington in Devon. Hills Quarry Products has also futureproofed aggregate supplies with planning approval for its largest gravel quarry to date at Down Ampney in Gloucestershire.

With eight concrete plants, seven quarries and a large fleet of tippers and mixers, including mini-mix, Hills is perfectly placed to fulfil orders of concrete, specialist concretes, floor screeds, stone, gravel, sand and unique, decorative aggregates.

Visit us: hills-quarry.co.uk
 Contact us: info@hills-group.co.uk

Hills Quarry Products

Suppliers of aggregates and concrete for every need:

- ready-mixed concrete, including mini-mix delivery
- sand cement floor screed
- Cemfloor liquid screed
- decorative aggregate
- sand, gravel and stone

Telephone:
01793 714999

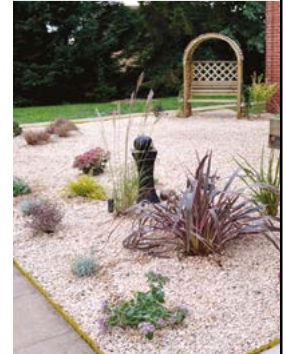

hills-quarry.co.uk



STONE PAVING SUPPLIES

Stone Paving Supplies is more than a distributor; they're renowned for seamlessly blending outstanding service with leading-edge products and prices. Working exclusively with landscaping stockists throughout the UK, their commitment to quality and affordability remains steadfast. Boasting an extensive selection of natural and porcelain paving, they cater to diverse needs, ensuring customers always receive quality products at competitive rates.

What's more, Stone Paving Supplies has established itself as a premier distributor and led the way in ground-breaking innovations, introducing the brush-in grout through its VillaFix brand.

Stone Paving Supplies stands out for its unwavering commitment to customer satisfaction in an industry where reliability and expertise are paramount. Their stock and price consistently surpass customer expectations, while products deliver durability and aesthetic appeal.

Stone Paving Supplies Limited is the definitive choice for those seeking the perfect blend of quality, variety, and affordability in paving solutions.

0333 600 4567 | sales@stonepavingsupplies.co.uk



Everything from traditional natural stone to contemporary porcelain paving.

- ✓ Wide range
- ✓ Huge stocks
- ✓ Great prices

Talk to us today...

0333 600 4567
sales@stonepavingsupplies.co.uk



STONEMORLD: REDEFINING EXCELLENCE IN URBAN AND LANDSCAPE DESIGN



In the dynamic world of landscape and urban design, each project tells a unique tale—a story crafted from creativity, innovation, and the beauty of nature. At Stoneworld, we understand the role that skilled craftsmanship and premium-quality materials play in bringing these narratives to life.

Located in Great Milton, Oxfordshire, our state-of-the-art masonry workshop is where we meticulously craft stone with attention to detail. Our skilled masons leverage the latest technology to bring your design visions to life, whether it is bespoke stone cutting or intricate designs. From natural stone flooring to garden features, our range of products elevates any landscape or architectural project with precision and efficiency.

Our collaboration extends beyond supplying stones; our expert team offers guidance from selection to layout, ensuring enduring outdoor projects.

We are delighted to announce that Stoneworld has recently attained ISO 9001 and 45001 certification, internationally recognized standards for Quality Management and Health and Safety.

By aligning our processes with international benchmarks, we ensure consistent excellence across all aspects of our operations. This highlights our dedication to delivering premium quality stone products and masonry services that surpass customer expectations.

Prioritizing the well-being of our team, we foster a culture of safety and responsibility throughout our organization, as reflected in our ISO 45001 certification.

As we celebrate this milestone, Stoneworld reaffirms its dedication to innovation, integrity, and customer satisfaction. Choosing Stoneworld means selecting a partner who shares your values and commitment to excellence.

**Get in touch with us today!
We are always happy to share our expertise on stone.**

stoneworld.co.uk

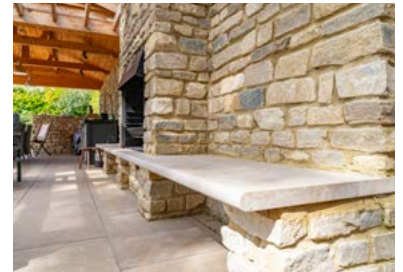

STONEMORLD



BESPOKE MASONRY SERVICES

STEPS | COPINGS | PIER CAPS | SCULPTURE | PAVING | WALLING | ROCKERY | WATER FEATURES

01844 279274 | sales@stoneworld.co.uk | Views Farm, Great Milton, OX44 7NW

MAPEI ULTRACARE - A COMPLETE PROTECTION & MAINTENANCE SOLUTION FOR HARD LANDSCAPING



enhancing and providing water and oil-repellent protection, to protection prior to grouting. All treatments are supplied ready to use and the water-based treatments can be applied directly onto dry/ slightly damp, clean materials.

In all environments, a good protection and maintenance regime is essential, in order to retain a tile's aesthetic and performance. In outdoor settings, this can be a particular challenge, especially with increasingly severe weather, greater footfall and the advent of heavily textured engineered tiles. In response, Mapei has developed the UltraCare range of cleaners and protectors. Formulated in the Mapei Research Laboratories, and designed for professional and end-user application, Mapei UltraCare provides a solution from installation right up to the protection and maintenance of surfaces in private and commercial settings. Treatments are formulated for all types of natural and engineered stone and tile finishes, from sandstone to external grade porcelain.

Cleaning external paving

Mapei's UltraCare cleaners are tailored to a tile's finish and individual characteristics. Each formulation provides a safe and easy-to-use solution for the most diverse sites, from new installations, to the renovation of existing paths, patios, parking areas and outdoor swimming pools.

For acid-resistant natural stone and tiles, like sandstone and porcelain, Mapei UltraCare Acid Cleaner and Mapei UltraCare Keranet are ideal choices for a landscapers clean and stain removal. Both safely remove fixing residue - including cementitious grout, organic dirt, salt, limescale and efflorescence. The 'buffered' formulations do not emit fumes, so they are safe for the applicator and for the environment.

To deep clean unpolished natural stone and textured porcelain pavers, the range includes an alkaline solution - Mapei UltraCare HD Cleaner. Ideal for renovating hard landscaping, the cleaner removes residue and organic dirt, moss and algae, restoring a tile's slip rating as well as its aesthetic. For ongoing maintenance of all types of stone and tile, the range also includes Mapei UltraCare Multicleaner. A concentrated pH-neutral cleaner, Mapei UltraCare Multicleaner gives a thorough clean without rinsing. To deep clean and remove dirt and grout, a lower dilution can be used and the surface is rinsed after application.

Protecting outdoor surfaces

Mapei's range of UltraCare protectors meet specific requirements - from colour

For paths, patios and other areas of paving, the range includes a number of water-based products: Mapei UltraCare Stain Protector W and Stain Protector W Plus both provide protection from water, oil and grease, with a natural effect; the added product feature of Stain Protector W Plus is that it can also be applied onto polished natural stone and polished porcelain. The treatments can be used on all types of natural, unpolished stone driveways and brickwork.

Mapei UltraCare Intensifier W protects and enhances medium-high porosity natural stone in a single product application. Mapei UltraCare Grout Release protects porous natural stone from grout ingress and staining and, on textured porcelain, it acts as a sacrificial surface protector that promotes quick and easy removal of grout and installation residues.

If installing external porcelain and grouting with a cementitious grout, then Mapei UltraCare Grout Protector can be applied to protect joints from staining.

For expert advice on cleaning regimes and more information about the Mapei UltraCare range, please contact: technical-uk@mapei.co.uk

GEOfabrics®

CuTex

Copper Composite Root Barrier



UK Design &
Manufacture

Stop roots, not water flow

Maintain natural hydrology with the proven permeable root barrier that's environmentally kind.

CuTex is a permeable geocomposite root barrier system, consisting of a specially formulated copper sheet encapsulated between two high-performance geotextiles. Developed and manufactured by GEOfabrics, a leading UK geosynthetics manufacturer.

- Permeable – maintains natural hydrology
- Safe & easy to install
- Enables biodiverse solutions
- Compatible with SUDs strategy
- Independently & scientifically assessed against numerous species

Find out how you can safeguard infrastructure from tree root damage, whilst maintaining natural hydrology – contact our team on 0113 202 5678 or visit www.geofabrics.com

UNIVERSITY OF LEEDS



RIBA
accredited
learning



PCA endorsed

SUDs > BREEAM



RECONSTRUCTION OF CENTRAL SQUARES

EXISTING CONDITION

The area of intervention can be segmented into three zones that form logical spatial units: Ban Jelačić square : a wide street with trees that occasionally hosts seasonal events; a square in front of the market: generator of the largest daily pedestrian and bicycle traffic; and the main city square Zrinski: an apparently oversized square bounded on one side by the green facade of city park, and on the other side by the facade of an unfinished block of various contents and the city hall to the east and the old "Podravka" building in the west. Each of the mentioned spaces has a specific potential that distinguishes

it from others, and the possibility of joining the system of public spaces in the center of Koprivnica. The main square of Zrinski, seen from the air, acts as an intersection of roads and pedestrian wpaths stretched between streets and smaller squares in the east and west. This spatial tension has made the main square of Koprivnica a transit place : a space defined more by flow and movement, and less by lingering and everyday activities. With intuitive lines of movement, cyclists bypass the vast empty space "cutting" the square diagonally in order to get from one end to the other as quickly as possible.

CONCEPT

Accepting the flow as an inevitability in the functioning of new city square, and bicycle paths as a kind of coordinate system, smaller zones are formed between the mentioned paths and the perimeter of the square. Zrinski square is like a collage of activities defined by micro-locational specifics.

A "tapestry" of smaller squares structured around the solid axes of bicycle paths in the form of an "X" has been laid on ground. Each zone corresponds directly with the purpose of the surrounding context or brings its own new amenity.

By using different urban equipment, light/shadow and different paving, we form an urban collage of possible smaller zones created with regard to the context and habits of citizens of Koprivnica. Neighboring squares become so-called "green vestibules", giving Zrinski Square clear visual borders.

PROJECT

The Zrinski Square is divided into twelve smaller zones. Each of these zones is adapted to the nearby building or micro ambience. For example: in front of the gallery there is an „art zone“ with pedestals for occasional exhibitions and circles for drawing on the floor. Under the maple trees is a "pop-up zone" for summer events. In front of the bars and restaurants are „coffee zones“ for parasols and tables.



The square is mostly made of concrete pavers of different dimensions, layout and processing schemes. The color of the pavers themselves is the result of a careful analysis of the facades of the surrounding buildings, historical heritage and the Podravina ambience itself.

Paths with reddish paving stones, which are a reference to old brick roads, are especially emphasized.

Multifunctional zones for occasional gatherings are ochre-yellow emphasizing their symboling importance, while other zones are in shades of gray. In the middle, there are mosaics - an interpretation of the famous Podravina embroidery. The bicycle lane "X" that crosses the square is made of rough-hewn concrete to emphasize the change in material. The new fountain, identical in shape to the old flower garden - rundele, is now a multipurpose fountain paved with gray flint sandstone. The fountain itself is lowered 2 cm in relation to the square, and can form a water mirror that reflects the park and the old Town Hall, while in the summer it becomes water playground for the youngest residents of Koprivnica.

The urban equipment of the square adapts to the environment and encourages different activities.

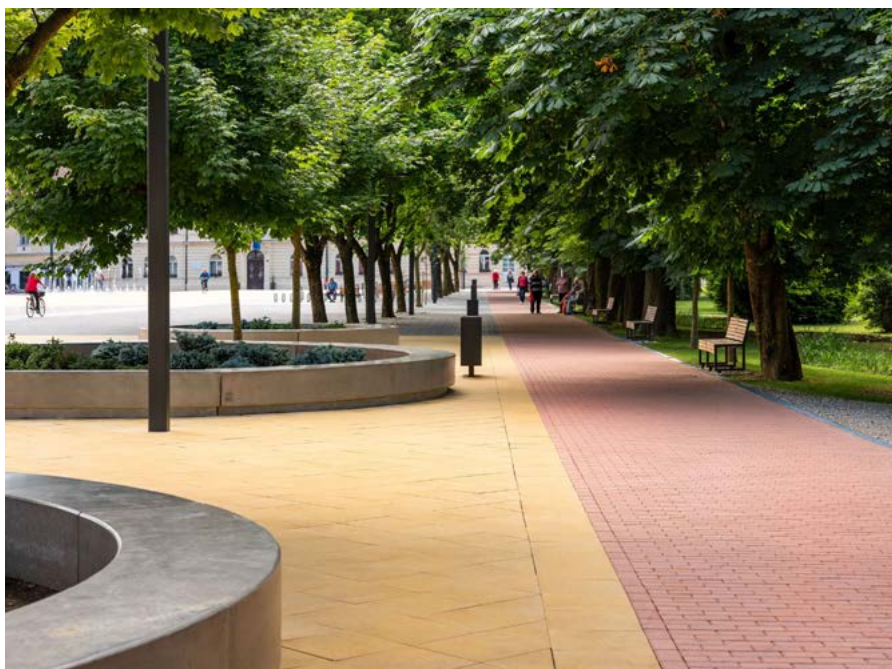

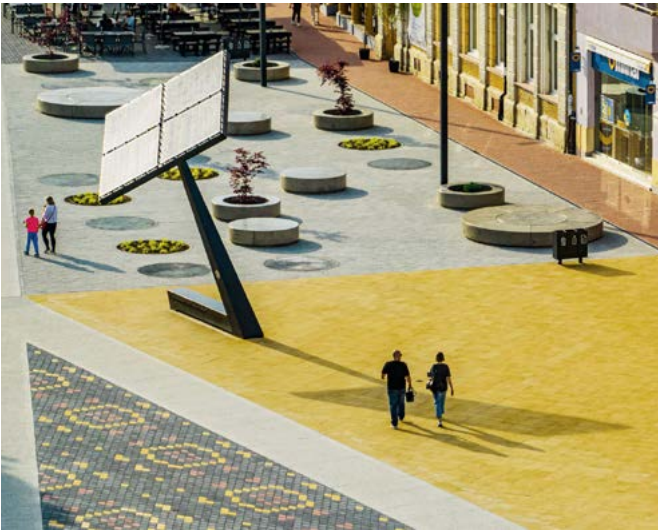

It includes wooden benches next to the park, benches/pedestals on the "art-square", benches-bike racks at the entrance areas of the square and concrete circular benches around the existing tall trees towards the Park. The area in front of the library and cinema is dominated by a solar tree equipped with Wi-Fi, power outlets and a screen displaying meteorological data.

Sculptures, such as the existing but also the new monument to cyclists, have been placed on the opposite sides of the Zrinski square. Horticultural species are mostly similar to those found on site. Ban Jelačić square and the Market square are additionally embodied with rows of maple trees *Acer globosum*.

Existing tree line on Zrinski square is added with maples and sofas with spruce bushes underneath. Red japanese maples are placed in the "art zone" inside circular benches/planters together with the *Ophiopogon* plant.

Architects: NFO

Area: 15000 m²

Photographs: Zoran Bakić, bosnić+dorotić, Filip Ružić

NICHOLAS PEARSON ASSOCIATES

Designing a better environment for our shared future

We are an independent, award-winning, multidisciplinary consultancy.

We provide complementary expertise in:

Environmental Design, Landscape Architecture, Ecology and **Visualisation**

For over 40 years we have brought a collaborative approach to delivering high quality, environmentally and socially responsible projects. We support a cross-section of clients at all stages of the planning, design, construction, and management process.

Our Complementary Specialisms

Environmental Design



Landscape Architecture



Ecology



Visualisation



Get in touch

The Farm House,
Church Farm Business Park,
Corston, Bath,
BA2 9AP

Tel: 01225 876990

info@npaconsult.co.uk

Follow Us



www.npaconsult.co.uk

www.npavisuals.co.uk



Find us online



SHOWCASE YOUR SKILLS AT THIS YEAR'S NATIONAL LANDSCAPE AWARDS

Entering the National Landscape Awards offers a host of benefits to landscape professionals and businesses. The prestigious Awards celebrates outstanding achievements in landscape design, installation, maintenance, and supplier and employer excellence, providing winners with unique opportunities for recognition, networking, and professional growth.

Participation elevates industry visibility and credibility whilst winning an Award demonstrates exceptional skill and innovation to peers and clients. This recognition significantly enhances a company's reputation and attracts new business opportunities.

Moreover, the Awards foster industry connections and networking. Engaging with fellow winners, judges, sponsors, and attendees opens doors to valuable collaborations and partnerships. Networking within the landscape community can lead to shared knowledge, referrals, and future project collaborations.

The rigorous judging criteria pushes entrants to strive for excellence, leading to advancements in design, sustainability practices, and overall service quality. Constructive feedback from judges can also guide participants in refining their techniques and approaches.

For businesses, winning a National Landscape Award can have a tangible impact on their bottom line. Award-winning projects often command premium pricing and attract high-profile clients seeking superior quality and creativity. The accolades serve as powerful marketing tools, distinguishing the winners from competitors and helping to secure new contracts.

Furthermore, the Awards provide valuable opportunities for personal and team development. Celebrating achievements as a team fosters camaraderie and boosts morale. Recognition through Awards can motivate employees to continue pushing boundaries and setting new benchmarks for excellence.

Participating in the National Landscape Awards contributes to broader industry advancement; by showcasing innovative designs and sustainable practices, Winners inspire others in the field to adopt similar approaches, ultimately raising the bar for the entire profession.

The benefits of entering the National Landscape Awards extend far beyond mere recognition. From enhancing professional reputations and fostering industry connections to driving innovation, participation in these Awards is a valuable investment for landscape professionals and businesses looking to distinguish themselves and make a lasting impact on the industry.

Entry deadlines and costs

Accredited Contractor & Group/ Accredited Designer Categories

Final Deadline: 3 June - £260.00
(Additional Entries: £235.00 per entry)

First Time Entrants Deadline: 3 June -
£155.00 per entry

Supplier Exceptional Service/ Employer Excellence Categories

Early Bird Discount Deadline: 3 June -
£225.00 per entry (Additional Entries:
£200.00 per entry)

Final Deadline: 5 July - £260.00
(Additional Entries: £235.00 per entry)

First Time Entrants Deadline: 5 July -
£155.00 per entry

International Category

Early Bird Discount Deadline: 3 June
- Fee £325.00 per entry (Additional
Entries: £300.00 per entry)

Final Deadline: 5 July - Fee £360.00
per entry (Additional Entries: £335.00
per entry)

First Time Entrants Deadline: 5 July -
£255.00 per entry



To start your entry visit
baliawards.co.uk.



BALI
National
Landscape
Awards



Headline Sponsor

OPEN FOR ENTRIES

Accredited Contractor & Group/Accredited Designer Categories

Final Deadline: 3 June 2024

Supplier Exceptional Service/Employer Excellence Categories

Early Bird Discount Deadline: 3 June 2024

Final Deadline: 5 July 2024

International

Early Bird Discount Deadline: 3 June 2024

Final Deadline: 5 July 2024

The National Landscape Awards Ceremony will be held on Friday 6 December 2024, JW Marriott Grosvenor House, Park Lane, London

 @BALI_Landscape

 balilandscapeuk

Visit baliawards.co.uk for entry criteria and to start your entry

For general enquiries, contact **Emily Feeney**
Telephone: **07936 944258**
Email: emily.feeney@bali.org.uk

For sponsorship opportunities, contact **Joanna Pieprzak**
Telephone: **07842 436597**
Email: joanna.pieprzak@bali.org.uk

HEADLINE SPONSOR



SPONSORED BY





BLOOMING URBAN LANDSCAPES

For two decades, Pictorial Meadows has been successfully supplying, installing and maintaining large-scale urban meadows which transform urban landscapes into vibrant, environmentally-conscious spaces.

This article delves into a variety of urban projects by Pictorial Meadows, exploring their approach in creating resilient and engaging nature-based solutions for diverse urban environments.

Meadows for Urban Brownfield Sites

With urbanisation on the rise, there is a pressing need for vibrant and cost-effective landscaping solutions that transform brownfield sites into aesthetically-pleasing spaces. Temporary meadows, composed primarily of annuals, have emerged as an effective solution. Pictorial Meadows' products have been used on over 150 hectares of development land, bringing not only colour and ecological benefits, but also effectively reducing anti-social behaviour. Research from the University of Sheffield validates the positive impact of Pictorial Meadows, fostering heightened feelings of happiness, calmness and relaxation among community members.

Grand Displays at Visitor Attractions

Iconic locations like the Olympic Park in London and The Tower of London serve as testaments to

Pictorial Meadows' ability to create impact on a large-scale and their ability to transform existing as well as newly redeveloped urban spaces. Over one hectare of meadows was planted across these two events. The Tower of London Superbloom Project alone utilised over twenty million seeds from twenty-nine flower species, creating an immersive, sensory experience which captivated visitors with vibrant flowers and buzzing bees. How much visitors enjoyed the spectacle was evidenced by the number of posts and positive comments on social media.

Highways and Council Initiatives

Local councils have harnessed the potential of Pictorial Meadows for highways, using them for central reservations, verges and roundabouts. Rotherham's nine-mile River of Flowers not only reduced maintenance costs and traffic management expenses, but also boosted biodiversity and motorist satisfaction. Testimony to this was, in its first year, the council received over 250 compliments about the extensive display.

Coventry, with its sowing of over three hectares of meadows, earned a Green Apple Award for its significant contribution to environmental 'greening'. The irony lies in the fact that these annual meadows which burst with colour were far from being merely green.

Perennials for Long-Term Impact

While achieving quick wins is easy with Pictorial Meadows' annuals, the focus on long-term solutions takes precedence with perennials. North Lanarkshire has reaped the benefits by utilising Pictorial Meadows to transform urban green spaces into flower-rich meadows, resulting in biodiversity gains and reduced maintenance visits. Solihull Council, through its Green Ways Project, emphasised long-term benefits by employing Pictorial Meadows' perennial flower turf on around fifty hectares.

Embarking on a large-scale landscaping project demands a reliable partner, and the reliability of Pictorial Meadows' products shine through when used in large projects. Pictorial Meadows' seamless blending of horticultural science, environmental management and creative design ensures the creation of successful, sustainable and visually-stunning urban landscapes every time.

Pictorial Meadows is part of The Green Estate Community Interest Company and offers a range of designer meadow seed mixes and turf, complemented by professional meadow creation, management and consultation services.

pictorialmeadows.co.uk

Pictorial Meadows

The original transformational
flower meadow

Expertly designed to deliver maximum impact for minimum input

Classic



Sundance



Aqua



Explore our new Seed Brochure

For detailed information about each seed mix, including:

- Plant Lists
- Flowering Details
- Recommended Usage
- Shade/Sun Tolerance
- Installation & Maintenance Tips



the
green
estate

COMMUNITY
INTEREST
COMPANY

pictorialmeadows.co.uk
0114 267 7635



FINNING SUPPORTS GARDEN SHOWCASING SUSTAINABILITY AT RHS MALVERN

Finning is showing support for an exciting new addition to the show gardens at RHS Malvern Spring Festival by donating one of the latest Cat® next generation mini excavators to carry out groundworks for the innovative creation.

The garden, created around the theme of ‘it doesn’t have to cost the earth’ has been designed by landscape architect, Michael Lote, and showcases innovative sustainable construction products and methods.

Mike is an advocate for creating beautiful gardens in an on-trend style with an environmental conscience, demonstrating that gardens can be both stunning and sustainable. The garden combines native species and a modern naturalistic approach and uses contemporary and reclaimed materials.

Keen to ensure all aspects of the show garden adhered to sustainability principles, Mike contacted Finning, the world’s largest dealer of Cat machines, parts and services, for help sourcing a

machine to carry out the earthworks that aligned with the project’s commitment to sustainability and the environment.

Following initial discussions, Finning offered to loan Mike the use of the latest Next Generation 1.5 tonne Cat 301.5 mini excavator for use in the scheme. The machine is fully compliant with the latest EU Stage V emissions regulations and compatible with renewable energy sources so can be run on either 100% renewable diesel or HVO (hydrogenated vegetable oil).



The machine is also fitted with a host of built-in technology features designed to offer high performance alongside operational efficiencies that reduce unnecessary fuel usage and subsequent greenhouse gas emissions.

Andy Davies, Head of BCP at Finning UK & Ireland explains: "The latest Cat machines come with a whole host of in-built technology features that have been specifically designed to support efficient operation - including reduced fuel burn which then generates less emissions, so seemed a perfect fit for this exciting show garden project.

"We worked closely with Mike to understand what was required for the show garden and were delighted to loan the use of a Cat 1.5 tonne mini excavator for a week to prepare the ground and complete the necessary groundworks.

"Sustainability is at the forefront of decision making today across both the agricultural and construction sectors, and we're seeing a real shift in our customers choosing machines that adhere to these principles."

This year's show theme is 'Gardening for change'. After the event the garden is set to be repurposed for

Woodoaks Farm - which is owned by the Soil Association Land Trust.

The farm is currently undergoing a transformation that will see it create permanent training and educational space to facilitate learning for school children and adults, growing together with the horticultural and agricultural industry. It will support a climate friendly future with plenty of biodiversity, improving habitat for wildlife and continuing to welcome people.

Garden designer, Mike Lote said: 'It doesn't have to cost the Earth' was inspired by personal experience in creating gardens for others. We are using beautiful recycled and innovative sustainable materials, some of which are a first for RHS shows and previously unseen in landscaping here in the UK.

"I'm extremely grateful to Finning for supporting this innovative garden project. It was interesting to learn about how equipment, such as the excavator we used, have evolved so they support more sustainable construction methods."



The RHS Malvern Spring Festival takes place between the 9th and 12th May

TAKE YOUR LANDSCAPE TO NEW HEIGHTS WITH OTTERBINE'S GIANT FOUNTAINS



In a nutshell, they're a quality product delivering a sustainable solution to any water body, but equally as important is the pleasure they bring to visitors, residents and onlookers, and this is delivered by the quantity of impactful features:

- Display heights of up to a staggering 90ft or 27m
- Magnificent multi-dimensional cascading patterns of up to 121ft
- Good fan pattern for impressive width across the lake
- Colour changing lights with a variety of coloured displays and sequences
- Water is kept clean and clear thanks to the unique screening system and an adjustable float to minimise unit visibility in the water
- All units are energy efficient and virtually maintenance free!

Constructed for ease of use, this line allows for operation in shallow operating depths of only 40ins or 1m, while large wheels on the frames improve mobility so the unit can be moved around the lake and eliminating the need for hoists and cranes during installation in most instances (installation really could not be easier!).

When choosing Otterbine customers make the decision to choose simplicity, ease, quality and quantity, plus a guarantee of a long life, all at a competitive price point. The collection comprises the Aqua Star, Aries, Equinox, Mystic, Polaris, Super Nova, and Triad, all featuring multi-tiered and multi-dimensional designs making it easy to find the right fit for the space and helping to make a space come alive.

For landscape architects, designers and contractors looking for the finishing touch to provide focus, impact and texture to the landscape they're creating, Otterbine is the solution.

Whichever fountain customers pick from the seven strong Giant Fountain range, they can be sure of two things: quality and quantity.

The quality comes from knowing:

- Otterbine provides the highest oxygen transfer and pumping rates in the industry - independent testing by the University of Minnesota and GSEE prove it

- These fountains keep water healthy by adding up to 3.3lbs or 1.5kg of oxygen per horsepower hour into the water and pumping over 920GPM or 199m³/hr per horsepower hour
- They treating the water above and below the surface, eliminating the need for chemicals and attracting wildlife
- They're manufactured with 316 marine-grade stainless steel - one of the highest on the market - making them corrosion resistant
- With an average lifespan of over 15 years and backed by an all-inclusive four-year warranty, they're built to last.

Find out how to take your landscape to new heights with Otterbine by visiting distributor Reesink HydroScapes at reesink-hydroscapes.co.uk

Effective water solutions
for all landscapes

MORE STYLE GIANT RESULTS

**Stunning and dramatic water features
for lasting impressions.**



Take your landscapes to new heights with giant fountains from Otterbine. Shallow operating depths combined with cleverly engineered features means these aerating fountains are easy to handle while still striking to see. If you're looking for a water feature that makes a statement without any of the drama, look to Otterbine.

reesink-hydroscares.co.uk



PLANT & GO® LANDSCAPER VEHICLE

The Plant & Go® Landscaper Vehicle from Advanced KFS Special Vehicles Sets the Standard in Low Floor Grounds Maintenance Vehicle Conversions

For decades, AKFS has remained the epitome of excellence in commercial vehicle design, construction, and innovation. As pioneers in the field, we have continuously pushed the boundaries to offer cutting-edge solutions tailored to diverse industries and sectors.

At the heart of our distinguished portfolio lies the Plant & Go® Landscaper vehicle - a true testament to AKFS's dedication to innovation and functionality. This groundbreaking vehicle is meticulously crafted to meet the unique demands of Grounds Maintenance teams with unparalleled efficiency.

Utilising the Fiat Ducato, and Peugeot Boxer Back to Back cabs, and the cutting-edge low floor chassis conversion of AKFS strategic partner Al-Ko Vehicle Technology

Group, our Plant & Go® Landscaper conversion establishes a benchmark for reliability and performance. At the core of the Plant & Go® Landscaper model lies a low floor design and a very generous payload capacity of circa 1430kg at 3500kg GVW, and 2330kg at 4500kg GVW.

Designed for maximum convenience and flexibility, the Plant & Go Landscaper vehicle features a width of 1810mm between the rear wheel arches, and comfortably accommodates most large ride-on mowers including cutting deck; supplemented by ample storage for tools and additional equipment. Crafted with the user's needs at the forefront of consideration, our low floor design facilitates easy loading and unloading, transforming how grounds maintenance tasks are executed.

We don't just stop at vehicle design; operator safety remains our top concern too - the Plant & Go® Landscaper vehicle features a low working height of just 530mm and includes an assisted tailgate as a standard feature, ensuring that



getting on and off the vehicle is both effortless and safe.

Our Plant & Go® Landscaper vehicle is fully customisable at the time of order, and offers a truly bespoke build based upon the end users exact requirements and commitments ensuring a vehicle fit for purpose and ready to work. Optional extras include winch systems, both floor mounted and raised tool storage lockers, LED work lights, and 360-degree amber strobes for complete street level visibility.

Contact our dedicated Grounds Maintenance Product Specialists today on 01246 250022 to learn more about our innovative range of Grounds Maintenance and Landscaping vehicles.

AKFS Ltd

Plant & Go®

Landscaper Vehicle



Scan me



Quote LAUD67 to our Product Specialists and receive a free "Cab Comfort Pack" on all orders processed before C.o.B 31/07/2024



01246 250022
www.advanced-kfs.co.uk



STRATEGIC PARTNER
AL-KO
QUALITY FOR LIFE

Built Without Compromise



LANDSCAPING ASSET FINANCE CASE STUDY FEATURE

By Propel Finance

Propel equips leading Landscaping business to drive growth

Propel recently financed a cherry picker for a leading Landscaping business; supporting the customer to achieve their development ambitions. Following this purchase, Propel helped the customer secure twelve more deals towards a range of business critical assets.

Feedback from the customer:

“We were initially referred to Propel as we required asset finance towards a cherry picker. We were impressed by the whole process, while the speed rate of securing the finance was very quick and efficient. The Propel team were outstanding; and the whole experience of dealing with them was excellent. We had so much confidence in Propel. It was a no brainer for us to return to them for further finance. They’ve since managed to help us purchase several other key assets such as woodchippers, cars, trucks and vans.”

Maintain your advantage

To discuss how you could benefit from an asset finance solution designed around your business, call Propel’s specialist team on 01633 982922 or email contact@propelfinance.co.uk.



Cutting Edge Machinery and Vehicle Finance

for Groundskeeping & Landscaping Businesses

- Access the latest machinery and vehicles immediately
- No large upfront payment, preserving capital
- Boost your cash flow by spreading the costs over time
- Flexible finance solutions tailored to your seasonal cash flow requirements
- Fixed payments protect your business against inflation
- Fast decisions, so no delays to important new contracts

Propel is the fastest-growing asset finance company in the UK; and has a track record of over 25 years in supporting Groundskeeping businesses in achieving their growth ambitions.

Talk to Propel's asset finance experts today for fast and flexible equipment and vehicle finance solutions designed to power your growth.

Finance is subject to status. Terms and Conditions Apply. Propel acts as a lender or a credit broker for business customers only.

contact@propelfinance.co.uk

01633 982 922

www.propelfinance.co.uk

CINDERELLA INCINERATING TOILETS FOR GREENDOWN SHEPHERDS HUTS

Searching for toilet solutions to match their eco-friendly, sustainability ethos, Greendown Shepherds Huts visited industry experts Pump Technology Ltd at their showroom in Aldermaston for advice on appropriate options. Pump Technology provided them with specialist advice on the tricky business of disposing of waste in an effective and environmentally friendly way, in both on and off-grid situations.

Clive Vare, Pump Technology Ltd’s Cinderella specialist, subsequently visited Greendown’s extensive production facility near Bath,

where he showed their team the three Cinderella incineration toilet options and explained their simple and straightforward installation and servicing.

Greendown will now use both gas and electric powered Cinderella toilet models, depending on their customers needs. These modern, eco-friendly, stylish incineration toilets are simple to operate (one push button on the control panel) and match their requirements perfectly.

Cinderella toilets do not require a water or a sewage connection. Incineration transforms



waste into odorless and hygienic, sterile ash which can be safely disposed of by tipping onto the garden.

For more information: 0118 9821 555 www.cinderellauk.co.uk

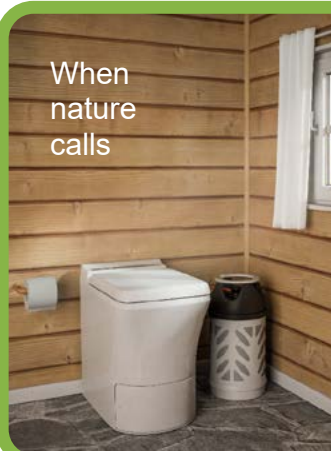

When nature calls



Cinderella® 0118 9821 555
Incineration Toilets

- Ideal for static sites such as: - Garden rooms, huts or ‘glamping’.
- And mobile situations such as: - Canal and house boats, vehicles or mobile containers. LPG gas (Propane) or electric versions available.

www.cinderellauk.com





Cost effective,
readily available,
hard landscaping solution



What is ChipTex

ChipTex is designed to give conventional (HRA) Hot Rolled Asphalt a cost effective colour demarcation & enhancement as well as increased durability. The clear binder coated chippings are simply rolled into the surface at the time of laying, enabling the colour to be maintained throughout its lifetime.

ChipTex uses

- Pedestrian areas
- Driveways
- Footpaths
- Highways
- Cycle & bus lanes

PSV requirements

Speak to our helpful team to discuss PSV requirements & availability.

Size

ChipTex is available in nominal sizes of 10 or 20mm.

Colour options

Alternative colours also available

Available in:



25kg Bucket



Tonne Bags



Bulk delivery

Manufactured to order.

F.H.BRUNDLÉ: SHAPING LANDSCAPES AND HELPING YOU BUILD THE DREAM



Michael Brundle, Managing Director of long-standing suppliers F.H.Brundle, walks us through the products helping landscapers and garden designers transform the outdoor environment.

We used to talk about gardens - now we talk about outdoor spaces.

What's changed? On the surface, not that much. We build homes with lawns and patios the same way we have done for decades. But it's the way we think about them that's shifted.

People loved gardens, but they often saw them as completely separate from the home itself. Since the turn of the millennium, that's totally transformed. Today, they're increasingly seen as an extension of the indoor living space.

This is why we've continued to expand our range of products, providing greater style, range, and flexibility to meet the demands of homeowners and landlords.

Outstanding decking

From our experience, few outdoor products have soared the same way decking has over the last 20 years. Today's cutting-edge solutions like aluminium, are a superior alternative to traditional wood decking and offer unparalleled durability as well as being non-combustible, making it a great option for balconies and high-rise buildings, as well as gardens. Moreover, its eco-friendly attributes make it ideal for the more environmentally conscious consumer.

But the scope of decking solutions extends beyond aluminium, with wood plastic composite (WPC) as the main contender in recent years. Combining the visual aesthetics of timber with enhanced durability and lowered maintenance, composite decking offers a cost-effective way of achieving the outdoor oasis homeowners are looking for.

First-class fencing

Fencing used to mean timber, but not anymore. Now, as with decking, alternatives like aluminium and

wood plastic composite (WPC) are the innovative front runners. Offering low-maintenance and available in a huge range of colours and finishes, aluminium and WPC offer the aesthetic versatility and performance landscapers and gardeners need.

Best-in-class balustrades

Modern design trends see glass increasingly integrated into both indoor and outdoor spaces and there is an extensive range of glass balustrades to choose from. However, there are a range of alternatives available, and our crossbar and stainless steel strand wire systems offer sleek and adaptable options that cater to a range of architectural needs without compromising on looks or practicality.

Elevate to another level!

Gardeners and landscapers alike are always looking for that something special to elevate their gardens and we think this could be it - Straightcurve@.

From modular garden edging to raised garden beds, the range has everything - quality, durability and elegance. Plus, this solution, which we have exclusive UK supply of, is perhaps the most flexible and versatile professional solution on the market.



**Interested in learning more?
For more information call free on
0808 134 2086, or visit
www.fhbrundle.co.uk/lp/landscapers**

Family merchants since 1889



Putting our customers front and centre.

It runs in our family.

F.H.Brundle has been operated as an independent family business since 1889.

Family means a great deal to us, which is why the F.H.Brundle brand has been built on traditional family values. With over 100,000 customers, we consider each of them part of the Brundle family. Our family means the world to us. And, like a family, we're here whenever you need us. Your landscaping product needs taken care of.

Our ever-growing product range is vast, now stocking over 10,000 products.

Handrailing | Decking & Subframe | Fencing & Gates |
Mesh Products | Balustrade | Garden Edging |
Ground Screws and *much, much more!*

Rated Excellent by our family

4.8 ★★★★★

★ Trustpilot

fhbrundle.co.uk | 0808 134 20 86





NiteLux®

YOUR GARDEN IN A NEW LIGHT

www.NiteLux.co.uk

info@NiteLux.co.uk

020 3916 5320

12V

COMPLETE SETUP IN 3 STEPS
PLUG IN & DONE



STEP 1

- CHOOSE YOUR LIGHTS AND MOUNTING BASES



STEP 2

- CHOOSE YOUR LINK CABLES AND CABLE CONNECTORS



STEP 3

- CHOOSE YOUR TRANSFORMERS A TIMER AND CABLE PEGS

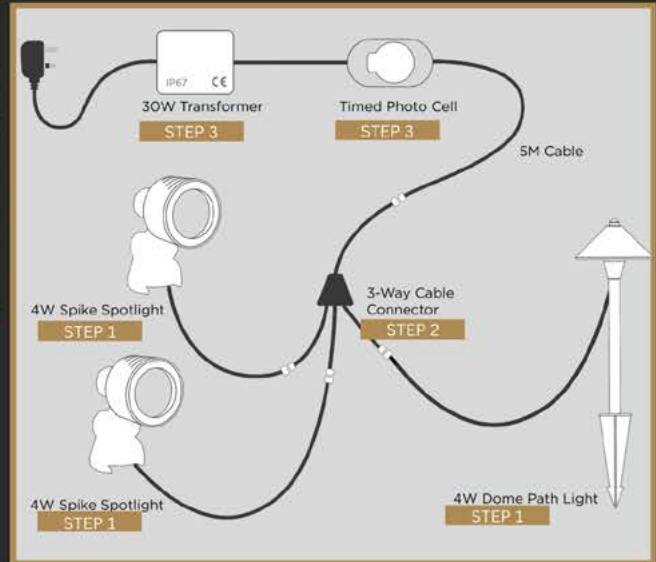

The Professional grade linkable lighting system.

NiteLux should be your top choice for garden lighting due to its blend of innovative technology, eco-friendly design, and unmatched performance.

PLUG IN & DONE



Best exterior lighting products

★★★★★ May 16, 2023

Best exterior lighting products around, the quality is second to none. The customer service from Paul is outstanding, really goes above and beyond when needing help or his expertise.

S L HALL Electrical Services



NiteLux®

YOUR GARDEN IN A NEW LIGHT



Illuminate Your Garden and the Planet: Nitelux Garden Lighting

In the quest for sustainability, every choice counts. Nitelux's innovative design, offers a comprehensive solution that not only brightens your outdoor spaces but also contributes to a greener, more sustainable future. Our partnership with Ecologi, a key player in global climate action, commits to planting trees worldwide and supporting essential environmental projects, contributing to a more sustainable planet. With a focus on accessibility, durability, and environmental responsibility, Nitelux stands out as a leader in the industry.



Nitelux plants trees on your behalf for every £20 spent

Trees planted to date: 18,912
Co2e offset: 38.05 tonnes
Projects funded: 28

Empowering Your Green Journey:

By choosing Nitelux, your company instantly joins the ranks of eco-conscious organisations and becomes part of the green movement, with the ability to track and showcase the positive impact of your contributions through the Ecology platform.

Ecologi



Paul Naylor - MD NiteLux:

Paul Naylor's journey from electrician to garden lighting innovator is a testament to his passion and expertise. Beginning his career as an electrician, Paul honed his skills before delving into garden lighting under the mentorship of industry veteran Dave Milsom of GLI Design.

Inspired by his mentor's guidance, Paul founded Greenlite, dedicated to designing and installing lighting solutions. With a vision for excellence, he later established NiteLux, a superior brand known for its innovative designs and eco-conscious approach. NiteLux stands out as a leading choice in garden lighting, reflecting Paul's dedication to quality and sustainability.

Why is NiteLux so different?

Paul's approach has always been to understand the problems customers could come across from 1st hand knowledge of installing landscape lights for over 20 years.

This is reflected in the huge knowledge base that has been acquired and which is regularly passed onto customers by advice tips and tricks which are freely given.



He often carries out free walks and talks on prospective installations giving advice on what to light and why. The feedback from landscapers, designers, and electricians has been very rewarding.

Paul gives all the help that wasn't available or wasn't freely given when he 1st started out in garden lighting.

WEEE Compliance:

Sustainable Disposal, Responsible Consumption
In adherence to WEEE regulations, Nitelux ensures the safe disposal of LED products,



UNIQUE, INNOVATIVE LIGHTING SOLUTIONS



The Solar Bollard from Zeta is a truly unique and innovative lighting solution combining sustainability with design.

A key feature of the Zeta solar bollard is to deliver a modern solar powered solution for exterior wayfinding illumination. Harnessing its energy from the sun, the bollards offer an environmentally friendly lighting option that doesn't rely on traditional electricity sources.

Zeta's standalone, self-contained solar powered bollards utilise solar energy using LED lights and can be specified for use along pathways and cycle paths, car parks, residential estates or in other public areas to provide illumination and enhance safety. The solar bollard can help reduce carbon emissions and decrease energy costs and is an attractive option to deploy to counter rising energy prices and budget constraints.

In addition to being environmentally conscientious, Zeta has prioritized the design element of the solar bollard. The extruded aluminium body offers a sleek and modern aesthetic that will seamlessly integrate into many types of outdoor spaces. The robust casing material provides durability and longevity, ensuring the bollards will withstand harsh weather conditions. Zeta's commitment to sustainability is further demonstrated with the uniquely designed solar bollard being available in sustainably sourced hardwood as a material choice for a long-lasting lighting solution, highlighting their dedication to responsible sourcing and eco-friendly practices.

Whether for commercial or residential applications, these easy to install bollards require minimal maintenance as they have no moving parts.



The solar bollards reliance on durable LED lights means less requirement for repair and upkeep - an appealing feature when looking to demonstrate commitment to environmental stewardship.

Solar bollards can also be easily relocated if needed, providing flexibility in their deployment. Installation costs are lower too with reduced disruption to the surrounding area during installation.

 zeta

For more information,
call the Zeta Technova team on
01869 322500

Unparalleled Solar Bollard

Zeta's uniquely designed sleek solar bollard integrates into any outdoor space from walkways and paths to residential estates for sustainable wayfinding illumination.



Features

- Integrated PV – four integrated panels ensure light capture from all angles
- Two motion-detecting PIR sensors and LED lights
- Zero trenching and running costs
- Specialist internal controller
- Year round performance with dark skies option
- Commercial, residential or heritage application
- Available in extruded aluminium in a choice of RAL colours
- Sustainable hardwood finish option
- Easy to install – surface or root mounting options





Quality Flexible LED Solutions

For Decking, Planters and Stairs etc

All colour temperatures available with 80 & 90 CRI

All dimmable via DALI, DMX, 0-10V,
Phase or Bluetooth App

5yr Warranty

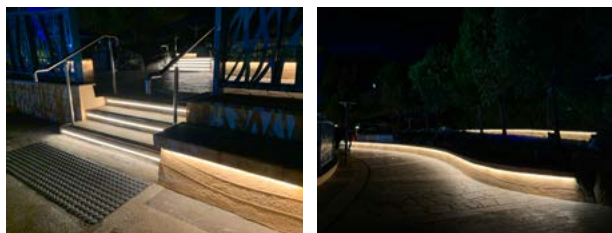

Contact us at sales@kempslighting.com
Or Tel 0113 263 9039

www.kempslighting.com

High performance outdoor LED lighting

Ideal for indoor and outdoor applications, such as garden and deck lighting, cabins, studios, garages or stables.



- Available in lengths of 5m, 10m, 15m, 25m
- Easily installed by a non-skilled person
- LIA UK approved
- IP65 rated
- 180 high output LEDs per metre
- 110v and 240v available



Site Lite
HIGH PERFORMANCE LIGHTING

Developed in the UK, SiteLite is a LED lighting system designed for the leisure and construction industry.

Call: 07974 171681

or email: geoff@cblimited.co.uk

THORN
LIGHTING

**LIGHT THAT
SHAPES IDENTITIES**

Take a look at our applications and lighting solutions at www.thornlighting.co.uk

A nighttime photograph of a garden scene. A brick pillar is illuminated from below, casting a warm glow. To the right, a stone statue of a child stands on a pedestal, also lit from below. A potted plant sits in the foreground. The background shows a brick wall and some bare branches. The overall atmosphere is serene and well-lit.

Gardenelectrician

.co.uk

Garden
lighting

that works

Kingson
Electrical

01442 531176

INNOVATIVE WOODEN CLIMBING FRAMES



A non-prescriptive form of play, the Playspaces pole climbers are fast becoming one of their most popular product types. Their innovative combination of wooden climbing frames and ropes provide a stimulating setting for children to play. Resembling the popular children's game 'Pick Up Sticks', the pole climbers' scattered appearance and non-uniform design creates a challenging play environment for children, encouraging the development of core balance skills, coordination and overall body strength. Children are also inspired to use their imagination while climbing, hanging or balancing, as well as thinking strategically about traversing the climbing frame. With a wide variety of sizes, styles and options there is a suitable pole climber for every play space, from Early Years upwards.

The pole climbers are just one part of Playspaces' vast selection of outdoor playground equipment. Playspaces provide an end to end service, including design, manufacture, supply and install of their bespoke equipment, providing individual play equipment pieces or complete turnkey playground builds.

Their extensive range of timber playground equipment has products suitable for every age and setting, including safety and all-weather surfacing. Their imaginative designs and robust high-quality installations are suitable



for schools, nurseries, parks, housing developments and commercial outdoor play areas.

Playspaces strongly believe in the importance of outdoor play and sport for children's development and enjoyment, and they strive to supply the best equipment to facilitate physical play, learning and fun.

Playspaces' physical play equipment and play schemes comply with the most stringent safety standards and all their manufactured products come with full installation instructions, with each component part simple to identify.

From trim trails and towers to swings, slides and climbing frames, Playspaces will work with you from initial site visits and design discussions, through manufacturing to installation as well as taking care of your subsequent safety and maintenance inspections and repairs.

enquiries@playspaces.co.uk | Tel 01622 844 238
www.playspaces.co.uk



Ask us about
our extensive
Pole Climber
range!



**Bespoke Design, Physical Play Equipment,
Outdoor Learning, UK Manufactured**



Find us on:   

T: 01622 844 238
E: info@playspaces.co.uk

playspaces.co.uk

+ WWW.MULTIMOVER.CO.UK

MULTI-MOVER
UK



ELECTRIC TOW TUGS



MOVE EQUIPMENT QUICKLY, SAFELY AND EASILY WITH A MULTI-MOVER ELECTRIC TOW TUG.

The range of Multi-Mover electric power tugs allow groundskeepers to push and pull lighting rigs and other wheeled equipment on turf. Our machines are specially adapted with grass safe tyres, ensuring no turf damage or signs of use. Easily operated, our movers do not require a driving licence, are silent, emission free and have more than a day's use from just one charge.

We understand that sometimes you may require a custom moving solution, at Multi-Mover UK we can do just that. From hitches to wheels, remote controls and more – We can build a machine to your exact needs.

FIND OUT ABOUT THE FULL RANGE OF MATERIAL HANDLING PRODUCTS:

WWW.MULTIMOVER.CO.UK | +44 (0)1952 771264 | SALES@MULTIMOVER.CO.UK



**EMISSION
FREE**



**TOW QUICKLY,
SAFELY & EASILY**

ECO RUBBER CHIPPINGS FIRM DOUBLES CAPACITY TO MEET DEMAND



A firm that manufactures environmentally friendly recycled rubber chippings, which are a welcome alternative to bark chippings, is doubling production capacity following demand from landscape gardeners, urban designers and contractors from across the UK.

Eco Rubber Chippings' products are produced from 100% premium recycled rubber in Yorkshire and are shipped across the whole of the UK.

Alex Ruff, from Eco Rubber Chippings, explained: "The increase in demand from customers has been significant this year, with more repeat business than ever before and numerous clients recommending us to others. This positive word of mouth means we have significantly upped our production capacity to meet demand.

"Our chippings provide a long-lasting, fade-resistant and weather-proof finish. Most importantly, they are made from quality recycled rubber, making them environmentally friendly and ideal for both people and animals.

"Landscapers, urban designers, and contractors prefer them over traditional bark chippings, because of their durability and the amount of coverage they deliver - with just 20kg required per square metre for use as mulch. As well as suppressing weed growth, they don't decompose or splinter. They are frost resistant, reduce moisture loss, provide excellent drainage, are non-slip and even deter cats from fouling!

"We get fabulous feedback on the eight vibrant colours available, with clients really liking how natural they look and how soft they feel, as well as how they last and don't need regularly replenishing."

Ideal for use in play and recreational areas, parks, forest pathways, nurseries, schools, gardens and bowling greens, clients include local authorities, park operators, garage forecourt operators, caravan and leisure parks, building contractors and specialist groundwork businesses, as well as those in the equine and poultry industries.

Alex added: "Anything from 20kg to several tonnes can be ordered online. We also provide free 1kg sample boxes to demonstrate the durability and staying power of our products over traditional chippings."

Eco Rubber Chippings' products are easy to handle and install, with no maintenance required. They have been tested and certified in accordance with the strict requirements of BS EN 1177: 2008 Impact Absorbing Playground Surfacing - Safety requirements and test methods. Eco Rubber Chippings is a British Association of Landscape Industries accredited supplier.



For a free 1kg sample email
alex@ecochippings.co.uk
using this code: LUD-ECO-CHIP
or visit www.ecochippings.co.uk
for more details

ECO RUBBER CHIPPINGS



Colour Variations



Safe, long lasting, trouble free, colourful ground cover.
Ideal for play areas, landscaping & animal settings.

01977 529 570 | info@ecochippings.co.uk

ecochippings.co.uk

DOOSAN BOBCAT EXPANDS GLOBAL BRAND STRATEGY

Doosan Bobcat has expanded its global branding strategy as it announces its RYAN turf renovation equipment will rebrand under the Bobcat trade dress in 2024.

75 Years of Tradition Continues RYAN equipment joined the Doosan Bobcat portfolio in 2020, following the acquisition of BOBCAT Mowers and the Steiner and RYAN brands from Schiller Grounds Care. RYAN has produced trusted turf renovation equipment for more than 75 years and features a unique product line-up including aerators, sod cutters, dethatchers, power rakes, overseeders and other speciality products that serve landscaping and grounds care professionals across a variety of industries including golf, sports turf, landscaping and rental.



Streamlining Branding Approach
Following the company's success in new product lines such as mowers, compact tractors and grounds maintenance equipment, Bobcat has streamlined its branding approach to strengthen overall brand equity, market recognition and consumer recall of all product offerings. The transition aims to create a cohesive customer experience and grow the organization's footprint, making the brand more accessible to more customers in more places.

"Bobcat has been a recognized name for decades - known for its toughness and versatility. We are proud to extend the brand to new product categories so we can empower even more people to accomplish more," said Scott Park, Doosan Bobcat CEO.

Earlier this year, Doosan Bobcat announced its Doosan Industrial Vehicle and Doosan Portable Power

brands would transition into the Bobcat product portfolio in Europe, Middle East, Africa and applicable markets worldwide in 2024.

"The Bobcat brand has experienced significant growth in recent years, and we acknowledge the potential to expand the brand in bold and innovative ways by introducing it into new product categories and growing their potential under one roof," said Jeongwon Park, Vice President of Marketing and Channel Development at Bobcat EMEA.

With this refreshed identity, RYAN products will undergo design and aesthetic changes in alignment with current Bobcat branding. The turf renovation equipment is produced at the Doosan Bobcat manufacturing facility in Johnson Creek (Wisconsin, USA) and will continue to be manufactured there following the brand transition.

Bobcat-branded RYAN equipment, along with its newly rebranded material handling and portable power is expected to be available for customer purchase through Doosan Bobcat's extensive, global dealer network in 2024. Bobcat and these rebranded product lines will proudly remain part of the broader Doosan Group portfolio.



For more information about Bobcat and its products, visit www.bobcat.com



Bobcat

TURN ANY JOB INTO A MASTERPIECE

There's nothing like watching a master at work. Years of practice and dedication turning your tools into an extension of your hands. Relying on bold vision, surgical precision, and the equipment you trust, for perfect results.

NOTICE: ALWAYS FOLLOW WARNINGS AND INSTRUCTIONS PROVIDED BY THE MANUFACTURER.
FOR MORE DETAILS VISIT WWW.BOBCAT.COM

KRESS GROUNDBREAKING TECH REVOLUTIONISES THE INDUSTRY



Kress has been making headlines in the groundskeeping industry for the past few years. Wanting to find out why? Read more to find out all the ways Kress has changed everything about how it is possible to work in this field.

Kress resets the standard on sustainable landscaping

Kress raises the bar for sustainability, productivity, and profitability. A groundbreaking battery technology is at the heart of the 8-minute CyberPack innovation, which leverages proprietary chemistry to deliver high-current flow without the typical heat buildup that accelerates battery degradation. This breakthrough allows for unprecedented power and a full charge in merely eight minutes, while ensuring unmatched longevity, backed by a 6-year or 3,000-cycle limited warranty.

To ensure continuous operation throughout the day, the Kress CyberSystem features a unique selection of portable DC-DC chargers, enabling ultra-fast, battery charging on-the-go, even when miles away from the nearest AC power source.

The new paradigm of power

Two- and four-stroke engines reach their maximum torque and power at high RPMs when they hit a sweet spot in their performance curve.

In contrast, as we know from EVs, electric motors maintain peak performance over a broad range of RPMs. Yet, conventional low voltage batteries, like those used for OPE, could only deliver high power by pushing the current to levels that would degrade or even damage cells.

Kress's 4 Ah 8-minute CyberPack on-board battery delivers the power equivalent of a 55 cc two-stroke engine, but with maximum torque delivered instantly at the pull of the trigger. This means instant power access without the wait, transforming operators' work experience with newfound efficiency and productivity.

Catalysing the shift through business model innovation

Kress is committed to advancing the expansion of green landscaping by offering a unique business model



designed to support landscape maintenance companies. This model revolutionises the traditional approach to fleet renewal by eliminating upfront costs, thus preserving working capital. The simple yet effective formula relies on manageable monthly installments, comfortably balanced by the savings from reduced fuel and maintenance expenses. The result? Enhanced profitability through pure profit, making the green transition not only feasible but financially advantageous.

Enhancing the environment and workers' health

The transition to zero-emission landscaping not only helps cities achieve their decarbonisation targets but also elevates the overall health and quality of life for its residents. Landscapers, who face the most significant risk associated with emissions from petrol-powered equipment, can experience immediate health benefits. Switching to Kress battery-powered solutions eliminates exposure to toxic exhaust fumes and significantly reduces the consequences of noise and vibration.

The revolution is underway

Transitions can only happen when a viable solution is available.

Kress transcends conventional battery limitations, blending advanced technology with an innovative business model to offer the only eco-friendly solution that promises significant long-term cost savings over fossil fuels.

Kress Commercial products are now available at select commercial dealerships throughout the UK and Ireland - [Kress.com/en-gb](https://www.kress.com/en-gb)



THE NEXT-GEN SOLUTION FOR SUSTAINABLE COMMERCIAL LANDSCAPING

Kress raises the bar for sustainability, productivity, and profitability. A groundbreaking battery technology is at the heart of the 8-minute CyberPack innovation, which allows for unprecedented power and a full charge in merely eight minutes, while ensuring unmatched longevity, backed by a 6-year or 3,000-cycle limited warranty.



Speak to your local garden machinery dealer today to learn more

[kress.com](https://www.kress.com)

ECO CLIPPER®

Efficient electric mowing systems for maintaining large area turfgrass



Eco Clipper FM4 Sport, 411 cm mowing width



NEW!

Eco Clipper FM343
343 cm mowing width

www.ecoclipper.com

FPM

AGROMECHANIKA

COMPACT TRACTOR ATTACHMENTS

farmtechsupplies.co.uk

01420 520510



the home of FPM

FARM TECH SUPPLIES
COMPACT TRACTOR ATTACHMENTS

BENBURGESS

www.benburgess.co.uk



PREMIER GROUNDS CARE EQUIPMENT RETAILER
WITH ELEVEN BRANCHES THROUGHOUT EAST ANGLIA, EAST MIDLANDS AND LINCOLNSHIRE

Club Car Carryall

The Club Car Carryall Series just got better! Club Car Carryall is designed to be rugged and versatile - no task is too big or too small. And now, with the addition of our brand new Lithium-Ion battery, the Carryall 500, 502, 550, and 700 are even more efficient than ever.



Whether it's grounds maintenance, landscaping, sporting fields and facilities, or anything in between, with a maintenance-free AC electric Lithium powertrain, you will spend less time getting ready for the work day and more time getting work done.



SALES | SERVICE | PARTS | HIRE

Find your local branch at www.benburgess.co.uk



Nothing but **HEAVY DUTY.**

M18 FUEL DUAL BATTERY SELF-PROPELLED LAWN MOWER 46cm



NEW
46cm
DECK

COMPACT DESIGN
FOR MORE MANEUVERABILITY

RUNS ON 2x 18V BATTERIES
FOR OUTSTANDING
POWER & PERFORMANCE

ADJUSTABLE SELF-PROPELLED
MECHANISM WITH
5 SPEED
SETTINGS





LOOKING FOR A LAP-BAR ZERO-TURN?

Cub Cadet has created their strongest line up of lap-bar zero-turn riders - whether you are a landscape professional looking for a machine that can handle any terrain or a small business owner looking for a machine for your customers large lawn maintenance.

XZ5 Series

The latest lap-bar technology combined with the extremely robust construction of heavy-duty components, high-performance engine and operator comfort makes the XZ5 Series the ideal machines for large lawn maintenance.

Powerful Cub Cadet and Kawasaki engines mean the machines can reach up to 12 km/h, mowing areas up to 12,500 m²h. The open continuous tubular lightweight steel frame designed for strength and durability with its hinged/removable floor pan allows quick, easy access

to the fabricated deck for ease of maintenance. With cutting widths of 42", 50" and 54" the three machines put comfort at the forefront of their design with individually adjustable seats and high backrests for fatigue-free working.

XZ7 Series

The XZ7 Series make a great impression with their strength, stability and durability. You can easily mow in comfort even under tough conditions.

A powerful Kawasaki (or Kohler EFI) V-Twin dual cylinder engine gives the machines the power to mow up to 15,000 m²h and reach up to 14.5 km/h.

The fabricated mowing decks are designed for high performance and resistance. Even on the most difficult lawns the spring-mounted suspension on the front wheels ensure a smooth ride with less vibration.

With large cutting widths of 48" and 60", the machines put comfort at the forefront of their design with a premium high-back seat with armrests and adjustable suspension for fatigue-free working.

At Cub Cadet we trust our machines to perform with maximum durability and robustness and offer a warranty of 3 years or up to 500 working hours (whichever comes first) on our XZ7 Series and 3 years on our XZ5 Series - as well as offering a dealership service that delivers true advantages to you and your business.

For more information or to book a demo go to www.cubcadet.co.uk/book-a-demo

Once tried. Never forgotten.

Cub Cadet[®]

FREE

DEWALT[®]

**OUTDOOR POWER EQUIPMENT WHEN
YOU BUY SELECTED MACHINES...**



XZ7
ENDURO SERIES

**WORTH
£499**



Our lap-bar technology combined with the robust construction consisting of heavy-duty components and high-performance engines help make the XZ5 and XZ7 Series the ideal solution for large lawn areas.

Now with the added bonus of a free DEWALT 54V Axial Blower designed for fast and effective removal of leaves, twigs, moss and other stubborn garden matter, suitable for blowing on wide areas.

Offer available from 1st March until 31st May 2024 while stocks last. Offer applies to selected XZ zero turns - XZ5 L107, XZ5 L137 and XZ7 L122. Prices listed are RRP. See your local dealer for more details. There is no cash alternative. Cub Cadet reserve the right to substitute the DEWALT equipment listed with an alternative and withdraw the offer at any time during the offer period. The Promoter of the offer is Cub Cadet, distributed in the UK and Ireland by E.P.Barrus Ltd. This offer is only available in the UK and Ireland. The registered address is Glen Way, Launton Rd, Bicester OX26 4UR

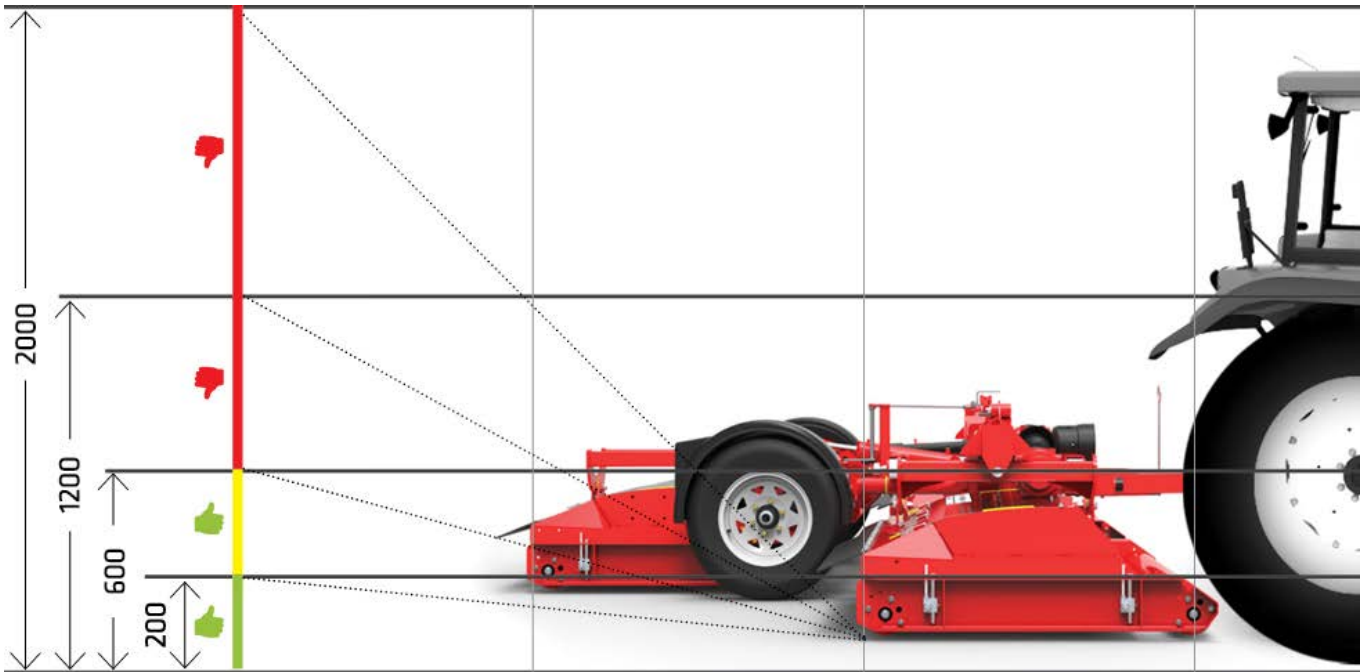

BEHIND THE SCENES - THE RIGOROUS SAFETY TESTING OF TRIMAX MOWERS UNVEILED

In the dynamic landscape of turf maintenance, where the wheels of progress are in perpetual motion, the unspoken hero is often overlooked. Picture this: the hum of machinery, the scent of hard work in the air, and the collective pulse of an industry beating with

ambition. Yet, beneath this bustling surface lies a crucial undercurrent - a commitment to uncompromising safety.

For Trimax, world leader in flail and rotary cutting equipment, safety isn't just a tick box exercise.

"From the design and development of our machines to the testing and manufacturing processes, safety is always at the forefront of our minds. We believe that by prioritising safety, we can not only protect operators but also enhance their productivity and efficiency." Caroline Shaw, Global Brand Manager at Trimax.

Here we've got an exclusive, behind the scenes look at the meticulous safety testing that every Trimax machine undergoes before it hits the market!

Thrown Object Testing

When cutting grass, mowers can come into contact with foreign objects like stones, sticks, and golf balls. When mowers come into contact with them, there is a danger that the struck object may be thrown and cause injury to the



operator or any bystanders. The thrown object test looks at how and where objects are dispersed. During the test, the machine is surrounded by specified targets and will run over sand and stones. To pass the test, no object can be thrown to the side or in the operator area, and only low impacts in the discharge area are acceptable.

Blade Impact Testing

Although Trimax blades are designed and made with durability in mind, in the event of a blade breakage, it must not fall in an unsafe way.

During testing, the mower is surrounded by targets. While the blades are moving, the mower is lowered onto a high-tensile steel bar.

To pass the blade impact test, there must be no loss of any part of the mower, and the targets must not be punctured by blades or any other part of the mower weighing more than 30g.

The purpose of this test is to ensure that if any part of the cutting system fails or comes into contact with anything that could cause damage, there is no hazard to the operator or anyone nearby.

Designing and Testing for Finger and Limb Safety

Due to the nature of a mower, it's imperative that fingers or limbs cannot get close to the blades, especially while in motion. For this reason, every hazard zone/ opening to moving parts has been carefully considered by Trimax, ensuring maximum safety.

Testing for Foot Access to the Cutting Chamber

Another important test is foot access. During testing, Trimax probes the cutting chamber with a dummy foot to evaluate the level of access around the machine, this ensures maximum protection for both the operator and any bystanders.



Trimax Mowers: Safer By Design
When it comes to safety, Trimax is setting the standard. Their uncompromising safety measures, extensive testing, and innovative safety features are what set them apart from the competition.

To find out more about the safety or testing of Trimax mowers, call 01933 652235 or visit www.trimaxmowers.co.uk

“

Changing the game for
turf care professionals

”

CEORA

Call today on 01844 278843
or visit farol.co.uk/ceora

CAPACITY

Pro Sports Quality
Approx 25,000m²

Pro Quality
Approx 50,000m²

Regular Quality
Approx 75,000m²

- Work areas
- Stay-out zone
- Transport path
- CEORA™ mower
- Charging station
- Maintenance point
- EPDS-reference station
- Cutting frequency (times/week)

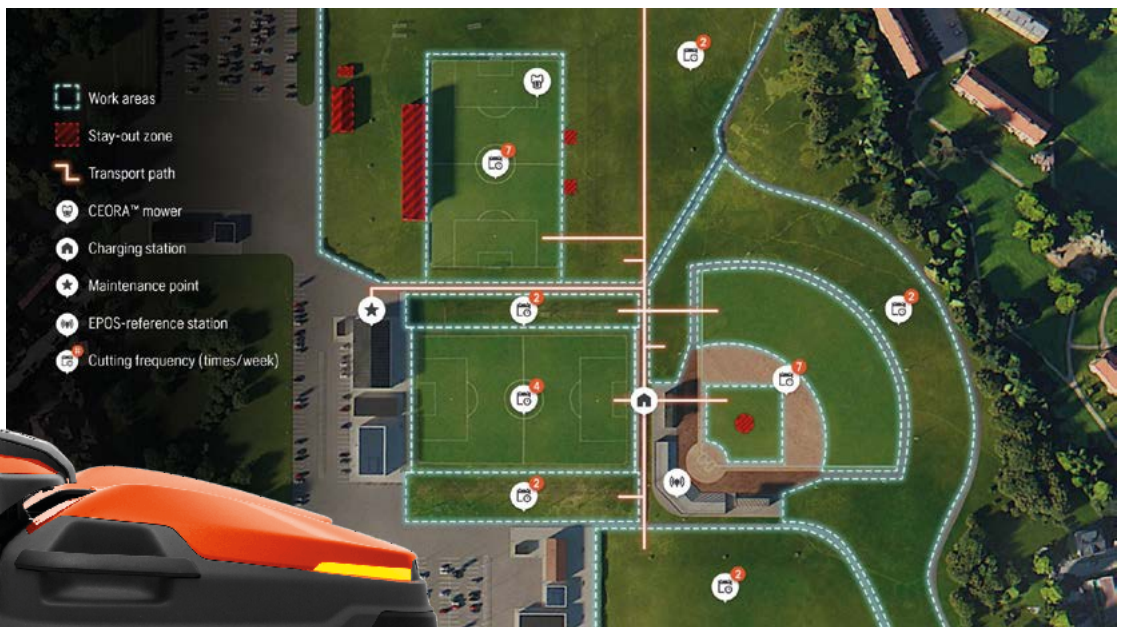



Husqvarna®



FAROL

Flexible and hassle-free zone management

CEORA™ is a state-of-the-art autonomous mowing solution guided by Husqvarna EPOS technology. Precise satellite navigation with virtual boundaries eliminates the hassle of physical wires. Quick definitions of work areas and stay-out zones accommodate optimal use of the turf, while aerating is made easier without the risk of damage wires. The robotic mower travels between work areas on defined transport paths, while temporary stay-out zones can be created for more flexible turf management.



Systematic mowing delivers a winning result

Cutting systematically in parallel tracks means CEORA™ is equally efficient whether managing football pitches or any other large green space. You can also define work areas and set a schedule where various times and different grass heights between 20mm and 70mm are specified. Schedule one pitch for a morning cut, and another for an afternoon cut at a different cutting height. Frequent systematic high-precision mowing offers the perfect result when only cutting a small amount each time.



Visit www.farol.co.uk/ceora for more information

J PREMIER PITCH MAKES IMPRESSIVE DEBUT AT DARTFORD FOOTBALL CLUB



Ticking the boxes for wear tolerance and fast germination, J Premier Pitch from Johnsons Sports Seed has impressed during its debut season at Dartford Football Club. Under the supervision of Head Groundsman Jay Berkhauser and the team at Jordans Sportsground Solutions, J Premier Pitch was chosen due to a tight six-week renovation window, delivering a quality surface for the first game of season and demonstrating great resilience, despite challenging conditions, ever since.

Jay has been in the industry for 20 years, working on all manner

of sports surfaces from Premier League clubs to grassroots facilities, schools, cricket clubs and everything in-between! For the last seven years he's been an operative for contractors Jordans Sportsground Solutions and has been based at Dartford FC, of the National League South, for five seasons. "This pitch gets a lot of use!" he exclaims. "We've got four teams that play here so when it comes to renovating and preparing the pitch we know we need seed that can handle high levels of stress and wear, and meets the budget and resources we have available."

"We'd heard about the quick establishment and germination of Johnsons, and with only five and a half weeks between our renovation and the first game, this was going to be critical. We sowed J Premier Pitch end of May 2023, saw the first sprouts of germination within seven days and by the first game of the season we were as good as gold!"

J Premier Pitch has delivered proven performance on some of the greatest sporting stages globally. The new 2024 formulation blends five top-rated perennial ryegrass cultivars to create a mixture with exceptional wear tolerance, disease resistance and outstanding visual merit. "After the impressive initial germination, we've also noticed the pitch has held up really well given the very wet winter and sustained high levels of play. There has also been a significant reduction in the amount of Red Thread we've seen in comparison to previous years."

"While we may not have the luxury of a big budget or two weeks of recovery time between fixtures, we still very much aim for professionalism in the product we deliver. By hand seeding goal mouths and spot treating problematic areas we can maintain a pitch that looks good and plays well for the whole season. J Premier Pitch, for us, has been the right balance of price and quality" he concludes.

www.johnsonssportsseed.co.uk

LANDSCAPE & URBAN DESIGN



Providing the UK's major landscaping and urban design specifiers with a comprehensive look at the latest in landscape design and management, design innovations, garden design, the built and natural environment, public space, green space, open space and environmental sustainability.

FREE DIGITAL MAGAZINE SUBSCRIPTION

Subscription enquiries:

Call - 01304 806039
info@mhmagazine.co.uk

Advertising enquiries:

Lee Martin - 01227 936974
lee@landud.co.uk

Editorial submissions or enquiries:

Antony Holter - 01304 806039
antony@mhmagazine.co.uk



SUBSCRIBE TODAY!

#designthenation

peach place, wokingham



01254 685 185

sales@woodscape.co.uk

woodscape.co.uk

woodscapegroup

woodscapectd

woodscape_street_furniture



Woodscape.

Bespoke Street Furniture