

LANDSCAPE & URBAN DESIGN

68

Jul/Aug 2024

Price £4⁹⁵

landud.co.uk



RHS Flower Shows make biggest and most exciting changes for a generation

Celebrating the best of UK horticulture, design and talent, taking the world-class Shows to stunning new locations around the country



The geometry of modular design

A series of seating and planter clusters for the City of London

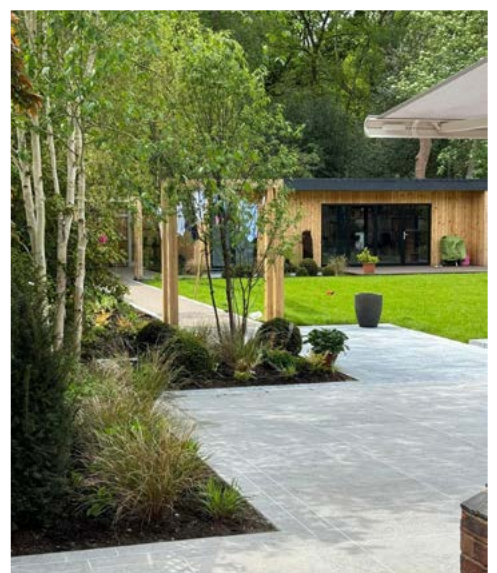

Transform your next patio project

The game-changing Big Spin Hurricane levelling system

Family merchants since 1889

SAVE
10%
on your next
web order*
Use Code
LURB0706



Putting our customers front and centre.

It runs in our family.

F.H.Brundle has been operated as an independent family business since 1889.

Family means a great deal to us, which is why the F.H.Brundle brand has been built on traditional family values. With over 100,000 customers, we consider each of them part of the Brundle family. Our family means the world to us. And, like a family, we're here whenever you need us. Your landscaping product needs taken care of.

Our ever-growing product range is vast, now stocking over 10,000 products.

Handrailing | Decking & Subframe | Fencing & Gates |
Mesh Products | Balustrade | Garden Edging |
Ground Screws and *much, much more!*

fhbrundle.co.uk | 0808 134 20 86

Rated Excellent by our family
4.8 ★★★★★
★ Trustpilot

*Discount applicable to web orders only. Strictly limited to one use per customer. Minimum order value £75. Expires 31.08.24. See Ts&Cs fhbrundle.co.uk/lp/10pcad/



CONTENTS ISSUE 68

THIS ISSUES MAIN FEATURES



Garden Design | 4 - 33



Tools, Plant & Equipment | 34 - 45



Decking | 66 - 77

Garden Design

4 - Some of the biggest and most exciting changes for a generation are being made to RHS Flower Shows, which will celebrate the best of UK horticulture, design and talent.

10 - Stylistic indoor-outdoor spaces from Daval furniture.

16 - In preparation of capturing the essence of summer, Sweetpea and Willow have been adding lots of gorgeous pieces to their outdoor collection, designed to transform your space into a luxurious retreat.

18 - Practicality Brown continued its tradition of excellence in 2024, providing top-quality instant hedges that helped bring 3 RHS special exhibits to life.

22 - Create a dreamy, Victorian English garden - Hartley Botanic's RHS flower show designer shares the key principles.

32 - Turn neglected weedy patches into stylish, statement areas with UltraScape's brand new product range.

Tools, Plant & Equipment

38 - With Kress RTKn mowers, Kress showcases the pinnacle of possibilities in automated mowing.

44 - An INFINICUT®FL22 was purchased by the team at Stanedge Golf Club to equip the Derbyshire venue with a mowing solution for periods of wet weather.

Green & Blue Infrastructure

48 - Greentech has recently collaborated with Flintshire County Council on an environmental initiative aimed at monitoring and improving the air quality at Ysgol Croes Atti Primary School.

Street Furniture

50 - Butler Wiltshire has recently completed a series of seating and planter clusters for the City of London, made from terracotta and repurposed timber.

Bound Surfacing

54 - Enhancing Aesthetics and Functionality with Resin Bound Solutions.

Decking

66 - Eva-Last's extensive range of bamboo composite products are specifically designed to enhance the environment while minimising any negative impacts.

72 - Revolutionise Your Outdoor Projects with EXADECK: The Ultimate Decking Solution.

76 - 4 expert tips for building a water-resistant deck.

Landscaping Services

82 - Celebrate Excellence at the National Landscape Awards.

Accredited
Members
of BALI



Publishing Director

Martin Holmes
martin@mhmagazine.co.uk

Sales Director

Lee Martin
lee@landud.co.uk

Digital Manager

Jamie Bullock
jamie@mhmagazine.co.uk

Editor-in-Chief

Antony Holter
editor@mmhmagazine.co.uk

Editor

Lorna Davidson
lorna@landud.co.uk

Business Manager

Josh Holmes
josh@mhmagazine.co.uk

Studio Designer

Sarah Johnson
sarah.johnson@mhmagazine.co.uk

Marketing Enquiries - 01227 936974
Editorial Enquiries - 01304 806039
Other Enquiries - 01304 806039

Publishers

MH Media Global Ltd.
18/20 Newington Road,
Ramsgate Kent CT12 6EE

Cover images courtesy of: Left: RHS / Neil Hepworth | Top Right: Butler Wiltshire | Bottom Right: Tilerite

Every effort is made to ensure the accuracy and reliability of material published in Landscape & Urban Design however, the publishers accept no responsibility for the claims or opinions made by advertisers, manufacturers or contributors. No part of this publication may be reproduced or transmitted in any form or by any means, mechanical, electronic (including photocopying) or stored in any information retrieval system without the prior consent of the publisher.



RHS Letters by Pinstripes & Peonies. Showground Installation.
RHS Chelsea Flower Show 2024. Credit: RHS / Sarah Cuttle

BIGGEST RHS SHOWS INNOVATIONS FOR A GENERATION TO REACH NEW AUDIENCES AND INSPIRE MORE PEOPLE TO GET GARDENING

Some of the biggest and most exciting changes for a generation are being made to RHS Flower Shows, which will celebrate the best of UK horticulture, design and talent, take the world-class Shows to stunning new locations around the country, and work with more communities and schools.

In the future, well-loved RHS Shows will tour to new locations to promote gardening to as many people as possible. The changes will be a catalyst for new content for an exciting visitor experience.

Whilst RHS Chelsea Flower Show as the world's greatest and most famous gardening event will stay as it is, RHS Hampton Court Palace Garden Festival will become a biennial event in two years with a new Show taking place in 2026 in the historic grounds of Badminton Estate, in Gloucestershire, returning to Hampton Court Palace in 2027. The RHS Shows will remain at Hampton Court Palace for 2024 and 2025.

After 2024, its 25th anniversary, RHS Flower Show Tatton Park will

return to the site every three years, with a 2025 RHS Show happening at Wentworth Woodhouse, one of the grandest stately homes in the country in South Yorkshire, and 2026 RHS Show taking place on the Sandringham Estate, the private country retreat of Their Majesties King Charles III and Queen Camilla.

The first RHS Urban Show took place in Manchester earlier this month and there will be another Urban Show announced for a new location next year shortly. The RHS Urban Show diversifies from the



St James's Piccadilly: Imagine the World to be Different. Designed by Robert Myers. Sponsored by Project Giving Back. In support of St James's Piccadilly. RHS Chelsea Flower Show 2024. Show Garden. RHS Chelsea Flower Show 2024. Credit: RHS / Neil Hepworth

"We want to inspire current and new audiences with world class horticulture and provide access to the UK's best plants people to help even more people garden and grow."

RHS Director of Shows, Commercial and Innovation, Helena Pettit finished: "We have been working with our existing partners over the last few years to ensure that we can continue to deliver the amazing RHS Shows in the iconic sites, whilst innovating in new sites and having the ability to grow the number of communities, schools, designers, nurseries and all stakeholders that the RHS collaborates with.

"We're excited about the opportunities these new partnerships in new locations will offer and will be able to get really creative with ideas and content for our visitors.

traditional RHS Shows model with more focus on gardening for small spaces and community involvement. RHS Malvern Spring Festival will remain the same.

The changes will enable the RHS to deliver world class horticulture to the doorsteps of members who may not have an RHS Garden near them and creating Shows in fixed venue sites means better sustainability opportunities too.

RHS Director General Clare Matterson said: "Our RHS Shows are without a doubt the best horticultural events in the world, however we must not and should not stand still. We owe it to the horticultural world, our invaluable RHS members, our visitors and our nation of gardeners to look at how and what we can do to create new content, work with new contributors and find ways to generate interest and inspiration both within our current much loved British events and in new locations with new Shows to work with new populations and people.

"These are some of the biggest changes we've made to our Shows in a generation and we're delighted to be extending our reach and making the RHS more accessible and welcoming to more people.

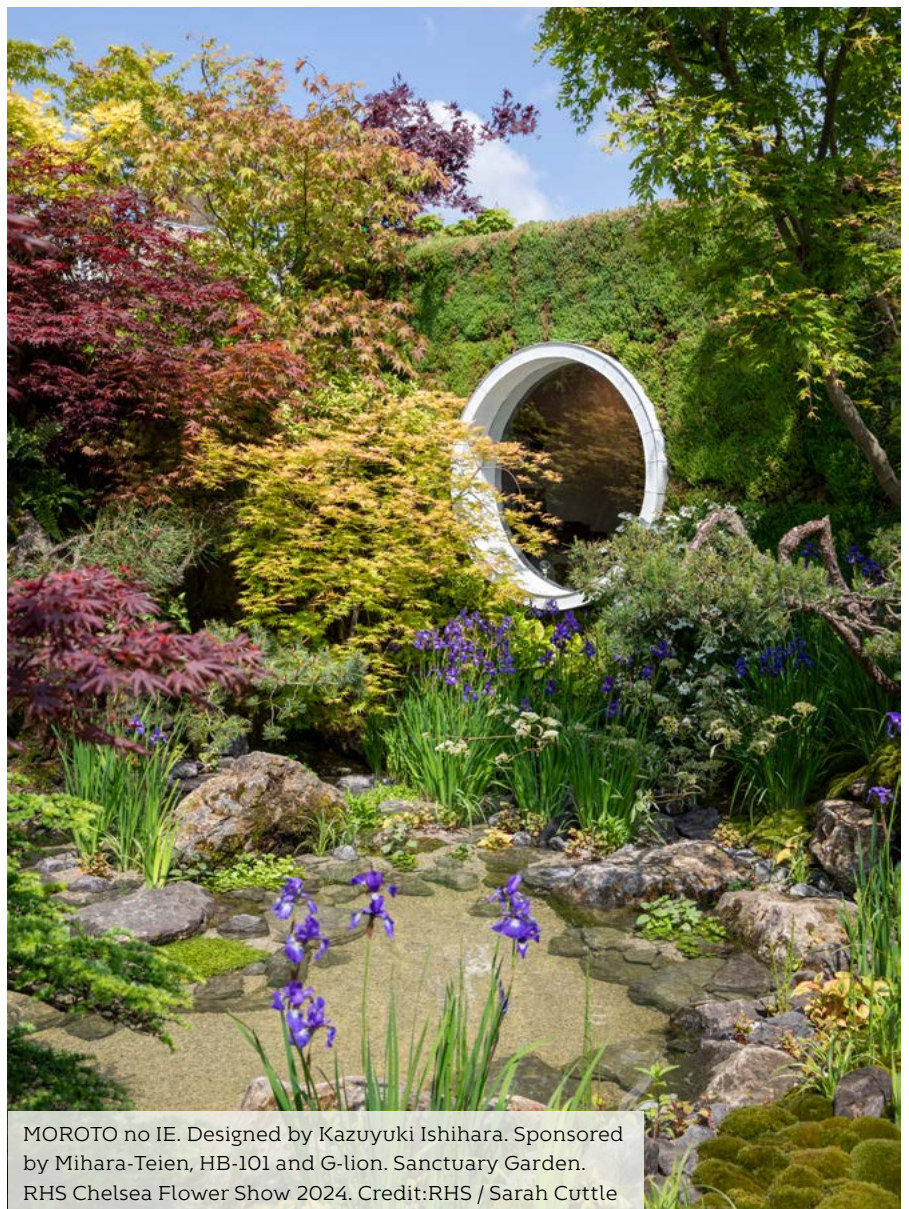

MOROTO no IE. Designed by Kazuyuki Ishihara. Sponsored by Mihara-Teien, HB-101 and G-lion. Sanctuary Garden. RHS Chelsea Flower Show 2024. Credit:RHS / Sarah Cuttle



RHS x UBS A Day on the Nursery: Insights into Life as a Grower. Designed by Emma Tipping. Sponsored by UBS. The Monument. RHS Chelsea Flower Show 2024. Credit: RHS / Sarah Cuttle



The Panathlon Joy Garden. Designed by Penelope Walker. Sponsored by Project Giving Back. In support of The All About Plants Garden. RHS Chelsea Flower Show 2024. All About Plants. RHS Chelsea Flower Show 2024. Credit: LineRHS / Neil Hepworth

At the same time we are delighted that we can continue to work with Historic Royal Palaces and Tatton Park to deliver these much loved events.

“We look forward to working with current friends and new to innovate and create the best horticultural events in the world.”



Flood Resilient Garden. Sanctuary Garden. Meteorologist and climate change expert Laura Tobin will weather through special effect rain and engineered flooding, highlighting how adapting outside spaces can protect against heavy rainfall. Credit:RHS / Oliver Dixon

Family merchants since 1889

SAVE
5%

on your next web order*
Plus FREE fire bowl with
orders over £500
Use Code
LURB0606



ADD STUNNING CURVES TO YOUR GARDEN.

straightcurve®

EXCLUSIVE TO



F.H. BRUNDLE

Bring your design vision to life with our premium steel garden edging range.



Garden Edging

- Safe, child-friendly design
- Designed for ease of installation



Raised Garden Beds

- Precision-engineered
- Unparalleled adaptability



Garden Planters

Ground Screws | Gabions | WPC & Aluminium Fencing |
Handrailing & Balustrade | WPC & Aluminium Decking |
Steel Railings & Gates and *much, much more!*

fhbrundle.co.uk | 0808 134 20 86

Rated Excellent by our family

4.8 ★★★★★



*Discount applicable to web orders only. Strictly limited to one use per customer.
Minimum order value £500. Expires 31.08.24. See Ts&Cs fhbrundle.co.uk/lp/5pcad/

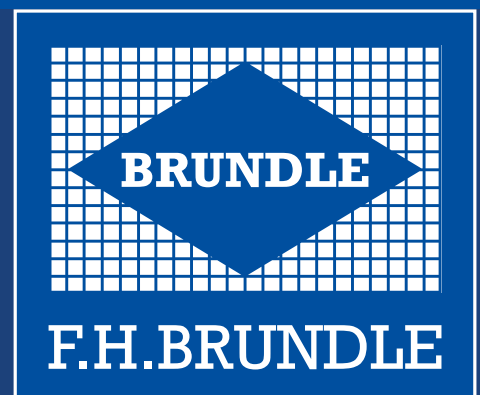



BEAUTIFUL POTS AND PLANTERS

Torc make everything from their studio in the British Isles creating beautiful pots and planters to enhance any outdoor (or indoor) space.

Working alongside a talented team of artisans this family run business really specializes in textures, scale and especially bespoke design. Their pots are shaped by hand until they take on their own unique form - no two pots are ever quite the same. When we are surrounded by so much that is mass produced Torc

believe there is a real appreciation for hand-crafted objects.

The design side of their business is getting busier all the time with landscape architects and garden designers alike realizing just how much expertise this company has to offer with a wealth of experience in design and problem solving to bring to the table. Torc welcome the opportunity to be involved at the design stage and are happy to contribute ideas when requested. Frequently being commissioned to

provide planter designs and outdoor furniture as a one-off template for both commercial and residential spaces.

Launching their new contemporary shaped water bowl this month was a good example of how far they can go - the diameter of this piece can be offered up to 3m wide. Their green credentials are pretty impressive too.

www.torcpots.com

TORC:POTS



www.torc-pots.com



@torc_pots



STYLISTIC INDOOR-OUTDOOR SPACES FROM DAVAL FURNITURE

Simon Bodsworth, Managing Director at Daval Furniture says, "The race for green space during the pandemic has brought a newfound appreciation to the home and garden, with several trends now coming together like biophilic design and sustainable living, which are helping to shape custom design schemes in and outside of the home.

For example, we are seeing a growing number of alternatives to the traditional conservatory or orangery, welcoming stylistically pure indoor-outdoor spaces that can function as an outdoor kitchen with alfresco dining, home office, gym, or simple garden retreat to entertain guests separate from the primary residence.

Homeowners are therefore keen to explore custom solutions which will enhance family life outside of the home with organizational furniture in garden rooms helping to cater to outdoor entertaining with the support of a fully operational kitchen complete with built-in appliances, integrated lighting, and ample storage space."

Daval Furniture were briefed to design and install a stylish made-to-measure home bar in a modern garden room at the Blake House. The homeowners wanted a dual space that works as both a home office, and place to host and entertain friends that's away from the main house and located in the garden.

The beauty of a garden room is even if the sun isn't shining, you can still enjoy a drink (or three!) in style because you're completely protected against the unpredictable British weather to create a private retreat complete with the latest fixtures and fittings.

The Blake House project features Daval Mayfair Bronze furniture, which forms a practical inset bar arrangement with custom fitted storage, integrated appliances, and statement mirrored backsplash. Characterised by its sophisticated mineral effect finish, this metallic stone effect finish creates a textured surface, which adds a layer of luxury to the handleless top units and grey oak structural elements.



The fully fitted furniture by Daval includes Mayfair Bronze base units and deep drawers with load bearing soft-close mechanisms and runners, adjustable display shelving and custom bottle storage to ensure a dedicated space to store the client's favourite fine wines.

Dual-purpose, the Blake House garden room offers enough space to have a dedicated area to work from home so as not to encroach on family life, as well as a comfortable leather sofa with coffee table to enjoy some much needed downtime.

Built from sustainably sourced materials and precision engineered in Britain, Daval Furniture is made-to-order and made-to-measure, with furniture starting from £12,000+vat.



T: 01484 848 500
E: enquiries@daval-furniture.co.uk
W: www.daval-furniture.co.uk
Daval House, Spa Fields Industrial Estate, New St, Slaithwaite, Huddersfield, HD7 5BB



LONDON GARDENERS

I am Samuel Davis, the horticulturist heading London Gardeners. With a lot of experience in changing landscapes into keen ones filled with beauty and life, I am eager to share some insights to make your summer issue of Landscape & Urban Design come alive.

As the summer approaches, it's time to take a fresh look and incorporate new ideas into your garden design. For private gardens, the combination of bright perennials with some soft hardscaping features can help in developing both appealing and low-maintenance landforms. Native plants greatly enhance your landscape's beauty while also helping to maintain local biodiversity and conserving water, which is vital to ensure during summer.

In a commercial landscape setting, however, one needs to make an appropriate balance between aesthetics and utilities. The addition of drought-tolerant plants and efficient irrigation systems greatly helps lower the maintenance cost while providing an inviting appeal. Smart irrigation tools like automatic irrigation controllers and soil moisture sensors optimize water usage while promoting sustainable landscaping.

Artificial turf has become the favorite choice for both residential and commercial landscapes because of its low maintenance and the fact that it stays green forever. When using artificial turf, one has to choose a good-quality material



that is durable and has the right landscape look. Installation with proper drainage and infills not only enhances durability but also vitally reduces damaging risks related to flood and turf degradation.

Green urban - the two words that fit right into modern cityscapes. Green roofs, vertical gardens, and furniture lining the streets made of recycled materials transform the urban space enormously. It's not only about the aesthetic factor; living green parts and furniture in this design have a positive effect on the air quality in cities, reducing urban heat islands, and building up a sense of community for all the people living in the city. Public spaces with proper arrangements of street furniture and green areas turn into dynamic social hubs promoting outdoor activity and facilitating and encouraging community interaction.

In today's green living world, encouraging certain practices, such as composting, rainwater harvesting, and organic fertilizer use, can do wonders within both private gardens and public landscapes. Not only do these methods diminish their environmental footprint, but they have a tendency to truly promote soil health and plant vitality.

For those starting or upgrading their garden project, working with a professional landscaping firm can provide expert know-how and help one get the job done right. At London Gardeners, we take pride in delivering tailor-made solutions that meet the unique needs of our clients, while sticking to principles of environmental stewardship.

www.londongardeners.org.uk
LinkedIn: <https://www.linkedin.com/in/samuel-davis-b650402b8/>

INNOVATION.

It runs in our family.

Innovative, pre-fabricated steel railings and balustrade taken care of.

Panels starting from **£68.50**
(ex. VAT)

- ✓ Test in accordance with BS 6180.
- ✓ All supplied from stock, for a quick delivery.
- ✓ Available in 3 styles including glass panels.
- ✓ High quality pre-galv & powder-coated steel.

Our unique adjustable on-site, pre-fabricated panel, makes gradients up to 40 degrees a breeze.

Mesh Panel Fencing | Mesh Gates | Sliding Gates | Cantilever Gates | Bow Top Railings | Estate Fencing | Palisade Fencing & Gates | Steel Railings | Vertical Bar Railings | Wrought Iron Components | Welded Mesh | Gate Hardware | Gate Automation and *much, much more!*

fhbrundle.co.uk 0808 134 20 86





CHOOSING THE RIGHT SUSTAINABLE WOOD FINISH

Consumers today are more conscious than ever about the sustainability credentials of the products they buy and use. There is a clear trend for switching to more sustainable and environmentally friendly products. That's why so many people turn to Osmo when looking for a wood finish, as it's not only high-quality, durable and easy to maintain, but it is also made from sustainable ingredients.

A Sustainable Solution

The foundation of Osmo wood finishes is based upon purified and refined natural resources which are carefully harvested into natural oils and hard waxes. Osmo products contain natural vegetable oils to help nourish the wood and retain flexibility. Depending on the product, they might include: linseed oil, sunflower oil, soybean oil as well as thistle oil. The interior

range of hard wax oil products also contains natural plant waxes carnauba wax and candelilla wax, offering wear resistance and repellency. Furthermore, our extensively cleaned pigments have been approved for use in the food industry.

Choosing the right finish

Osmo's mission is to preserve the natural beauty and durability of wood with only the highest quality and environmentally friendly products. Products made from wood; from flooring to furniture, are made from organic matter, so will continue to need nourishment to ensure the product stays in the best possible condition, both aesthetically and structurally. Our advice is to make use of a high-quality finish, full of natural ingredients to complement the woods properties. This will ensure that the wood continues

to breathe and respond well to environmental conditions, removing any possibility of cracking or and blistering.

FSC® Certification

Osmo supports sustainable forestry and works diligently to ensure that the origin of timbers used can be proven. To help improve, and with our natural resources in mind, Osmo has taken on the high standard of FSC®-certification for certain products. In choosing an Osmo product, you can be reassured that the product is not just good for wood, but good for the environment too.

For more information on Osmo and its range of environmentally friendly and sustainable products and finishes, call Osmo UK direct on 01296 481220 or alternatively visit www.osmouk.com

NATURAL WOOD FINISHES



Sustainable, plant-based, natural, and Eco-friendly are some of the terms we use to describe our products. This is due to the 5 core natural ingredients within our products, that create our high-performance wood finishes.



SCAN ME!



OUR INGREDIENTS:



Sunflower Oil



Thistle Oil



Soya Oil

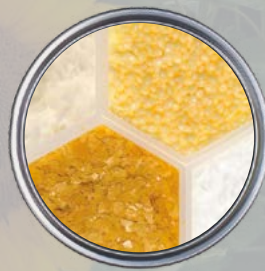

Candelilla Wax



Carnauba Wax



Highly Repellent



High Coverage



Natural Ingredients



Breathable



SUMMER STYLE GUIDE WITH OUTDOOR FURNITURE

In preparation of capturing the essence of summer, we have been adding lots of gorgeous pieces to our outdoor collection, designed to transform your space into a luxurious retreat. Seamlessly blending style and functionality, our Sweetpea Seasonal Style Guide unveils a curated selection of must-have pieces that will redefine outdoor living, letting you bask in the beauty of summer with unparalleled elegance.

JUST LANDED: WILLOW'S OUTDOOR COLLECTION

Our newest Willow's Collection invests in both style and sustainability, bringing the textural elements of wood and rattan to the outdoors. Contrast the natural finishes of the furniture bases with soft, white upholstery to brighten your outdoor haven whilst inviting that timeless, beleric feeling to your space.

SHOP WILLOW'S OUTDOOR COLLECTION ALFRESCO ACCESSORIES

As we transition into the warmer evenings, we expect people to take their dining entourage outdoors. Our collection features a number of dreamy dining accessories, from cutlery and crockery to placemats and parasols, these are the perfect pieces for creating an occasion to remember.



Mykonos Outdoor Lounge Set



Ibiza Sunlounger - Natural



Mykonos Outdoor Pull Out Sofa

Tahiti Outdoor Lounge Set



Bora Outdoor Round Dining Set



Esteli Outdoor Lounge Set

Azelia Placemats - Set of 4



Orca Jug - White



Eichholtz Santiago Bowl - Black

SHOP DINING ACCESSORIES
OUR EDITOR'S TOP PICKS

We simply adore the timeless design and irresistible comfort of the Scoop Armchair. Featuring a natural frame and rope detailing, alongside a plush cushion for extra irresistibility, this piece is as captivating as it is comfortable. The perfect spot for winding down with a book in the warmer evenings.

Boasting graceful curves and a smooth cream finish, this outdoor coffee table is an ideal timeless addition to any minimalistic décor. The luxury piece makes for a subtle stylish statement whilst bringing a natural feel to your garden as you soak up the sunshine.

RHS CHELSEA FLOWER SHOW AND PRACTICALITY BROWN 2024



Practicality Brown have been supplying hedges and trees to Garden Designers at Chelsea for over 20 years. In 2024, Practicality Brown continued its tradition of excellence, providing top-quality instant hedges that helped bring 3 RHS special exhibits to life.

All About Hedges

One of the highlights was the Discovery Zone feature, designed by Dave Green in collaboration with RHS Science. This exhibit focused on the importance of hedges in urban and suburban landscapes. Practicality Brown supplied a selection of their Practical Instant Hedge™ range, including Yew, Privet, Elaeagnus, Portuguese Laurel, and Griselinia. These hedges showcased how well-chosen plants can enhance urban environments by providing privacy, reducing noise pollution, and supporting local wildlife.

RHS x UBS: A Day on the Nursery

“A Day on the Nursery” was designed by Emma Tipping. This Feature

Garden aimed to give visitors an immersive experience of a day in the life at a plant nursery. Practicality Brown supplied their Practical Instant Native Mix Hedge™, a diverse and wildlife-friendly hedge composed of Hawthorn, Hornbeam, Hazel, Blackthorn, and Common Privet. This mix not only provided an aesthetically pleasing backdrop but also highlighted the ecological benefits of native plant species in garden design.

Abeba Esse

This showground installation, designed by Zak Ové and Dave Green depicts a Black Diasporic journey, with planting representing Africa, the Caribbean, and the UK. The garden encourages important conversations about the themes. We supplied Practical Instant Native Mix Hedge™ as a back drop to the exhibit and the yew at the front.

Practical Instant Hedge™

Practicality Brown's Practical Instant Hedge™ is a flagship product that has become a favourite among

Garden Designers. These pre-grown hedges offer immediate impact, transforming spaces with their lush greenery and mature appearance. Available in various species and styles, these hedges are perfect for creating privacy screens, defining garden areas, and enhancing the overall aesthetic of any landscape.

Practicality Brown's contributions to the RHS Chelsea Flower Show in 2024 underscore their position as Instant Hedge Specialists. Their high-quality not only enhance the beauty and functionality of the garden designs but also promote sustainability and biodiversity. Supporting garden designers with their expert knowledge and superior plants, Practicality Brown will continue to be part of RHS events, whether its for the Chelsea Flower Show, or the Hampton Court Garden Festival.

For more information about Practicality Brown visit www.pracbrown.co.uk



Native Mix: 1.8-2m Instant Hedge



Ligustrum japonicum (pleached)



15 varieties of Practical Instant Hedge available

WHEN SHOULD YOU PLANT HEDGES OR TREES IN YOUR GARDEN?



Magnolia grandiflora



Photinia Red Robin



Purple Beech: Grown in 1m long pieces in hedge bags

Traditionally, the best time to plant semi-mature stock is during the autumn/winter, whether its evergreen or deciduous. However, our hedges and trees have been carefully curated and maintained to be planted anytime of the year, even during the growing months.

Our Practical Instant Hedge™ has been produced to ensure that it is easy to handle and plant all year round, with no transplant shock. We have designed this instant hedging range to give you plenty of choice, depending on your garden style, local soil, and weather conditions. It's also ideal for use as a partition or screening to divide your garden into sections.

All of this means, any time of year is the perfect time to plant Practical Instant Hedge™.

We also specialise in screening trees, and

we currently have over 800 in stock at our nursery in Iver, Bucks. We have such trees available with a clear stem up to fence panel height of around 1.8-2m with a full bushy canopy, or pleached (trained to a narrow canopy) or fully feathered trees. These trees are containerised, meaning that they are currently growing in large pots, and are ready to plant and thrive in your garden.

Choosing a product from Practicality Brown means that you save time! We have grown and produced these large hedges and tree, so you can appreciate the mature effect from the moment its planted.

All our hedges and trees are listed on our website. We can help you choose too, simply email us hedge@pracbrown.co.uk

Book a visit or chat to our Horticultural team to find out more.



Screening Trees



Instant Hedge



www.pracbrown.co.uk

Contact us for details
email hedge@pracbrown.co.uk
or call 01753 652022 for more information



TRANSFORM THE OUTDOORS IN AN INSTANT WITH READYHEDGE



Expertly Grown

Readyhedge ready to plant hedges are grown to be fully mature, under the watchful eye of our hedging experts. This ensures every tough of hedging is identical and already knitted together to provide stunning hedging, instantly.

Our aim is to fulfil orders in 48 hours, we offer secure and punctual delivery to any location within the country.

For more information contact Readyhedge on 01386 750585 or visit www.readyhedge.co.uk

Follow us on Social Media:

Facebook @Readyhedge Ltd
Twitter @Readyhedge
Instagram @readyhedge

Give your garden project and instant uplift with ready to plant hedges. Suitable for all garden types, both commercial and domestic.

At Readyhedge you can choose from:

- Metre long lengths
- Various heights - from 30cm tall to 200cm tall
- Available in Readyhedge bags or Readyhedge troughs

Our hedging expertise spans 20 years+, producing over 50,000 metres of instant hedging per year in over 35 varieties. This includes individual plants, low and high panels and even screens.

Wide variety of hedges

Discover the large selection of evergreen, deciduous and mixed native hedging available. There are quick growing hedges, semi evergreen, formal hedges, and even low maintenance hedges to choose from!

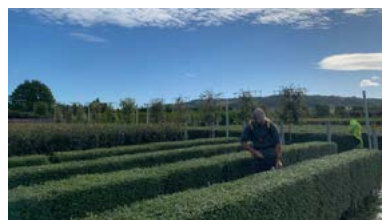

PROVEN QUALITY AND RELIABILITY FROM THE HOME OF INSTANT HEDGING

READYHEDGE

Readyhedge hedging plants, like the mixed native hedging shown here, are container-grown in the UK and fully acclimatised to UK conditions. With over 20 years' experience, Readyhedge delivers hedging to rely on, wherever you are.

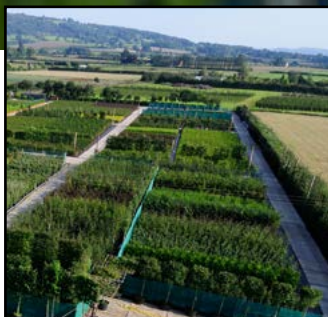

01386 750 585

info@readyhedge.com

readyhedge.com

EXCEPTIONAL PRODUCTS | EXCEPTIONAL SERVICE | BESPOKE FABRICATION

Lux Unique design and manufacture bespoke high quality steel garden products in the UK.

The team behind Lux Unique are family and fabricate all their own products in Cheshire. They have a wealth of state-of-the-art machinery and expertise at their disposal and are very experienced in all aspects of steel fabrication and design. Over the last few years, the company has grown to support many garden designers and clients in creating bespoke pieces for their outside spaces which are beautifully designed and will stand the test of time.

The popularity of Cor-ten steel known for its exceptional strength, longevity and zero maintenance has seen this material become the product of choice for so many landscapers and garden designers. Lux Unique offer a minimum thickness of 3mm on all Cor-ten products because to offer a thinner material would simply compromise on the quality and strength of the product, something many of their competitors do.

The company also offers steels products in powder coated and galvanised finishes.

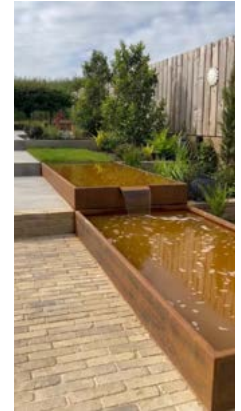

The in-house design team, technical engineers and fabricators mean that Lux Unique have total control over the design and manufacturing process from inception to completion and can work with clients to create truly bespoke, high quality crafted pieces.

The team has created many bespoke pieces for clients including planters, raised beds, water features, ponds, steps, and garden edging, working with designers on all the technical aspects of

their ideas to come up with solutions to suit the space and budget.

Its commitment to high standards has placed Lux Unique at the forefront of bespoke fabrication for the garden industry, bringing superior quality UK made products to the market and offering a personal one-to-one service for all its clients.

T: 03333 66 11 30

Email: hello@luxunique.co.uk

W: www.luxunique.co.uk

LUX UNIQUE

Bespoke Steel Garden Products

www.luxunique.co.uk

hello@luxunique.co.uk

(t) 033 33 66 11 30

Planters | Ponds | Edging | Raised Beds



CREATE A DREAMY, VICTORIAN ENGLISH GARDEN

HARTLEY BOTANIC'S RHS FLOWER SHOW DESIGNER SHARES THE KEY PRINCIPLES

This year, at the RHS's Chelsea Flower Show and Hampton Court Palace Garden Festival, Hartley Botanic, England's most historic and respected Glasshouse and Greenhouse manufacturer, tapped into the timeless charm of a Victorian English garden with its 'Simple Elegance - A Traditional English Garden' tradestand. The manufacturer showcased its beautiful, handmade Glasshouses within a design and planting scheme inspired by the English gardens of the Victorian period, a nod to the longevity of its structures, and a celebration of the era's opulence and elegance.

Landscape Architect Rachel Sampson (BA(Hons) Dip. CMLI,) who designed the planting scheme, shares how you can achieve this iconic look in your own garden.

Key Characteristics of a Victorian English Garden

Quintessential English, Victorian-style gardens are known for their ornate and lush aesthetics, geometric and symmetrical planting and their abundance of flowers - with roses being a staple. Throughout the summer, these gardens are a riot of colours and scents. They capitalise on beauty and fragrance, creating a lush

and inviting outdoor space which appeals to the senses.

1. Planting Techniques

The way plants are arranged can significantly influence the garden's overall look. Here are some techniques to consider:

- **Structure with Topiary:** Start by incorporating clipped topiary, such as cubes, spirals, pyramids, domes, and beehives, to create a strong framework.
- **Layered Planting:** Infilling with of plants, layering perennials for varying heights and foliage, and ensuring overflowing borders.



- **Plant in Odd Numbers:** Use groups of odd numbers (3, 5, 7) to create a natural and soft appearance, with a “one that got away” to avoid overly rigid symmetry.

2. Geometric Shapes and Structure

Victorian gardens often feature symmetrical layouts with precise, geometric designs. Paths, flower beds, and lawns are arranged in orderly patterns, often centred around a focal point like a fountain, Glasshouse or statue.

- **Clipped Topiary:** As mentioned above, use topiary shapes like cubes and spirals for structure.
- **Linear Paths and Lawns:** Defined by perennial borders that overflow with plants.
- **Vistas and Focal Points:** Utilise classic geometry to create interesting views and focal points throughout the garden.

3. Essential Plants to use

- Roses - The heart and soul of an English garden, offering both beauty and fragrance.
- Peonies - With their large, lush blooms, Peonies add a touch of opulence.
- Dahlias - These vibrant flowers contribute a range of colours and intricate shapes.
- Foxgloves - Tall and elegant, Foxgloves add height and a cottage garden feel.
- Hollyhocks - These towering plants bring a sense of old-world charm and grandeur.



- Full Green Foliage: Ensure ample greenery to fill in spaces and create a lush backdrop.

4. Colour Palette

A Victorian-style English garden often features a harmonious mix of whites, purples, and pinks, with bursts of hotter yellows and oranges in late summer. This palette provides a stable yet dynamic structure, ensuring year-round visual interest.

5. Tree Choices

Choosing the right trees is crucial for adding both structure and seasonal interest to your garden. Native British species are a great choice, including:

- Malus (Apples) - Offer spring blossoms and autumn fruit.
- Acer campestre (Field Maple) - Known for its autumn colour.
- Fagus sylvatica (Beech) - Provides excellent foliage.
- Carpinus betulus (Hornbeam) - Adds a structure in winter.

6. The Role of a Glasshouse

Glasshouses were integral accessories and status symbols for the most elegant and wealthy



gardens of the Victorian era in England. They were used to display the tropical and subtropical plant collections which were brought back from around the world by explorers and Botanists.

In a Victorian garden scheme, a Glasshouse serves as both a beautiful centrepiece, anchoring the garden's design, and a functional space for cultivating a variety of plants which would otherwise be limited by the local climate. It adds both aesthetic and practical value, reinforcing the garden's overall theme. Within larger Hartley Botanic structures, partitions can separate growing and lifestyle spaces - allowing you to entertain or admire your Victorian-style garden under glass.

All Hartley Botanic's Glasshouses and Greenhouses are handmade, bespoke, and made to order.



Customers interested in purchasing a Hartley Botanic Greenhouse should visit www.hartley-botanic.co.uk or call 01457 819 155 for more information

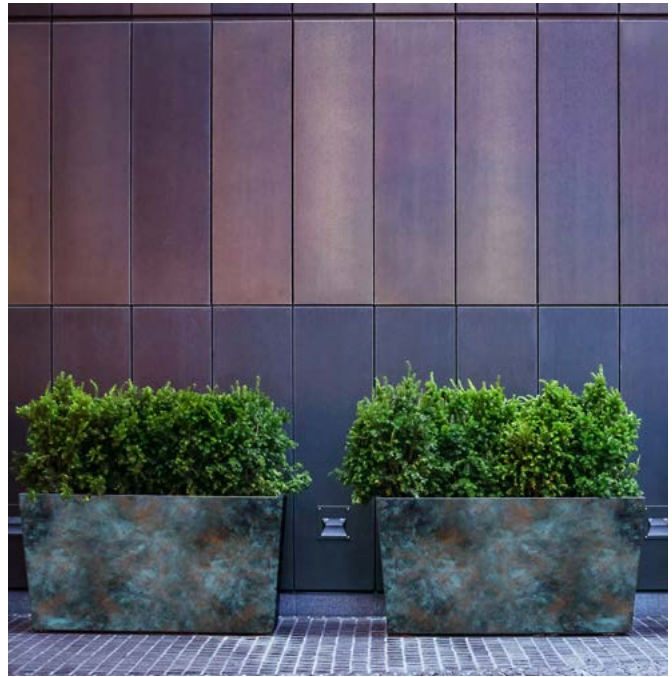

POWDERTECH CORBY CELEBRATES THE BEAUTY OF METAL

Where once, powder coatings, in their primary role as metal protectors, firmly hid the underlying metal from sight, the desire to celebrate the natural beauty of metal has made many exciting design choices available to architects, designers, landscape professionals and fabricators.

Staying on the cusp of advances in powder coating technology

Powdertech Corby is positioned at the forefront of this trend, creating unique ranges of finishes that respond to these design requirements through the latest developments in powder technology.

Powdertech Evolution™/Aged-Metal, launched in 2017, reflects the beautiful patination and oxidation effects which occur naturally on metals if left exposed - except in this case the metal is not exposed, but protected by the powder coating. These finishes have a strong tactile appeal, presenting the roughened

texture of aged metal. Particularly popular in this range are the 'Rust' finishes, chosen by clients as a preferred alternative to Corten steel, combining a 'natural' look and the enormous benefit of colour stability without any water run-off staining onto groundworks or water features.

Taking a soft approach

Ongoing conversations with designers led us to launch PowderLUX® in spring 2024. This unique range of patinated finishes are smooth to the touch reflecting patinated coppers, burnished bronze, blackened steel and marbled effects in soft pastel shades.

Meeting sustainability considerations

Evolution/Aged Metal and PowderLUX have low environmental impact. They contain no volatile organic compounds, halogens or heavy metals in manufacture, application and use. Powder coating is a factory-controlled application so there is no on-site impact

ensuring that up to 95% of what is sprayed adheres to the metal and the little that is left over can be re-purposed. Clever specification and use of Powdertech coatings can reduce the consumption of copper, lead, zinc, brass and bronze without compromising on visual appeal and in many cases reducing cost and improving re-cyclability through use of highly abundant and recyclable aluminium. The finishes are easy to clean and at 'end of life', powder coating does not affect the recyclability of metals.

Both Evolution/Aged Metal and PowderLUX® can be applied to aluminium or steel, for exterior or interior use.

For more information on these and other Powdertech finishes please visit www.powdertechcorby.co.uk.

Also, give me a call or email me:

**Richard Besant,
Richard.b@powdertechcorby.co.uk
+44 (0) 1536 400890**



PowderLux® celebrates the beauty of aged-metal with a glorious silk-smooth matt finish. Unique to Powdertech, PowderLUX® finishes deliver outdoor super durability replicating patinas ranging from aged copper, rust, blackened steel, tarnished bronze to distressed wood.



Sea Foam



Tarnished Bronze



Urban Steel

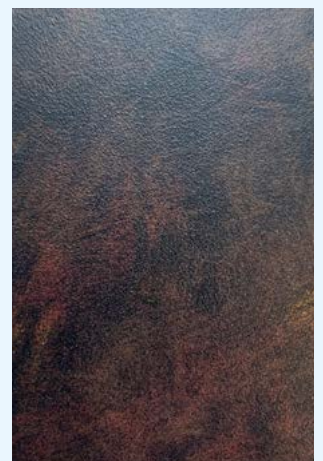

Autumn Rust

Contact: Richard Besant
Email: richard.b@powdertechcorby.co.uk
Visit: www.powdertechcorby.co.uk
+44 (0) 1536 400890

PowderLUX® patina
Ageing without the waiting



SUNNY DAY SAVERS – VONHAUS LAUNCH NEW AFFORDABLE GARDEN FURNITURE RANGE

Spring has sprung a little later than anticipated this year, but there's still plenty of time to get your garden heatwave-ready with homeware and garden retailer VonHaus.

The Manchester-based brand has just launched a brand-new garden furniture range which comprises

of 3 different sets, all of which go by the name of Alba. You can choose from a 6- or 8-seater dining set, or if you're looking for something a little more casual, there's also a reclining garden sofa set available.

Following an increase in demand for affordable and high-quality

outdoor furniture, the range - which is constructed with robust steel and durable PE rattan - is an ideal choice as its water-resistant and UV-resistant qualities mean they require minimal maintenance, resulting in the sets lasting many more years than other options out there.

Each set is easy to build and comes with anti-slip feet, giving you peace of mind about your lounging set-up, whilst also protecting your patio flooring from scratches, scuffs, and other marks.

Whilst these sets are fantastic value, VonHaus understand that spending upwards of £300 can be a big expenditure all in one go, which is why they have recently launched a new payment method: DivideBuy.

You can spread the cost on VonHaus.com, interest free. DivideBuy interest free credit is available on products/services from £250 to £2000. Credit is available from 4 to 8 months. Credit offered is set by the retailer.



www.vonhaus.com



MATERIAL CHANGE COMPOSTING LTD



With 6 composting sites across the Midlands and the East of England, we have been recycling organic waste for over 22 years, turning it into a valuable nutrient rich Soil Improver containing phosphate, potash, magnesium, manganese, small amounts of Nitrogen and trace elements.

We ensure that the compost has gone through the correct quality procedure meaning our Soil Improver is certified PAS:100, ensuring safe handling for you and your garden.

You can have our landscaper's grade of 0-12mm soil improver delivered in bulk bags or larger quantities of loose loads.

Our dedicated friendly sales team will be able to guide you through the order process and provide information and help with regards to our products.

01449 722318 | enquiries@material-change.com
www.material-change.com

Material Change Composting Ltd, The Watering Farm, Creeting St Mary, Suffolk, IP6 8ND

Rockways provide the ideal solution for your garden water feature needs as well as 3D backgrounds for aquariums and vivariums

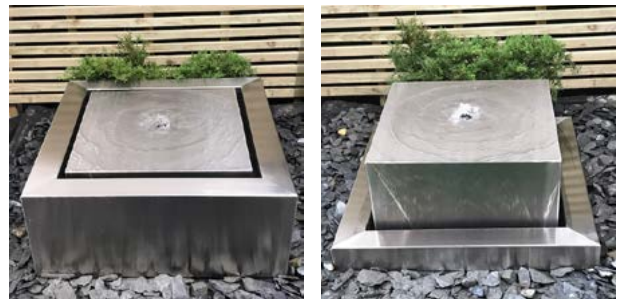

New for 2024

- Stainless/Corten Steel and polished concrete modern square water features. Bespoke facility available.
- Lightweight Artificial Rocks
- Resin and Concrete pond cascades



www.rockwayswaterfeatures.co.uk

Email: info@rockways.co.uk | Tel: 01376 514345

Create Stunning Ponds, Lakes & Water Features



Are you working on a water feature, lake, or nature pond? No matter the size of your project, our hands-on expertise will not only help you achieve your vision but also ensure it flourishes.

For over thirty years, our small, family-run nursery has grown and supplied pond plants across the UK and beyond. We take pride in helping to create beautiful water features that clients love.

With our extensive experience, we are able to provide not just advice but genuine, tailored guidance from the initial design to the final stages of planting and aftercare, ensuring your project is a true reflection of your vision.

Our Services Include:

- Design and landscaping support
- Planting plans and guidance
- Future-proofing solutions
- Supply of true-to-name plants
- Specialist plant advice
- Detailed care guides
- Ongoing support

Contact us today to start your project.

Let us help you bring your client's water feature to life

enquiries@pondplants.co.uk | 01684 310950 | www.pondplants.co.uk

DISCREET AND ELEGANT WALL LUMINAIRE

Outdoor lighting around buildings must provide reliable orientation and harmonise seamlessly with exterior and interior designs.



The Solution:

Discover TRILUX's Invego LED, a luminaire that excels in all settings. Available in square, round, and rectangular shapes, and various sizes, Invego can be recessed or surface-mounted. Its defining feature is the perfect fusion of light effect and design. With high-quality illumination and exceptional light distribution, it ensures reliable navigation while its elegant, discreet design enhances any space, indoors or out. Offering four distinct designs, two sizes, and dual mounting options, Invego LED is a testament to adaptability and aesthetic appeal. This product line is renowned for its superior light quality and timeless, sophisticated design, making it a reliable choice for diverse applications.

www.trilux.com/products/gb/Outdoor-lighting/Wall-and-ceiling-mounted-luminaires/Invego/?retainFilter=true



BENEFITS OF ADDING ARTIFICIAL TURF



of being pristine not just in the summer months but all year round. This means you can utilise your small garden area with minimal effort, minimal upkeep, and minimal stress.

“This then provides the ideal foundation to add in complementary landscaping and decorative features with the artificial grass underpinning the whole aesthetic, such as planters or decking. Having a small outdoor space, such as a terrace or courtyard, doesn’t mean you have to compromise on usability, and artificial lawn is a great, versatile and easy solution to achieving the ideal garden.

“Additionally, people aren’t aware that they can be kind to wildlife too. Beneath the lawn a habitat is created for animals such as worms to thrive, and to add back to the environment we often surround the artificial grass with flower beds, adding a splash of colour and providing for the insects and bees.”

What equipment do you need?

“Before you start laying your new artificial grass, you must first correctly prepare the ground where your new grass will be laid. To do this some basic tools you will need is a shovel or spade, rake, and Stanley knife or precision scissors. Some less common tools also include a wacker plate - also called a vibrating plate and plate compactor or a ‘vib’ plate - which are available from a large selection of local tool hire companies for a relatively low cost.

“Also preferred is a turf cutter - which can you hire too This isn’t necessary for creating your new lawn but will save you many hours of labour-intensive work removing your current natural grass.”



Comments from Adrian Buttress, managing director of PermaLawn on the benefits of adding artificial turfs into gardens to create a clean and minimal maintenance area, as well as the best practices and tools needed to install.

What are the advantages of turf?

“Artificial lawns hit the sweet spot in between form and function. If you have a garden that is limited in space, adding in an astroturf is a quick and easy way to add some class, elegance, and greenery to an otherwise small and unusable area. “Likewise, not everyone has time or enjoys garden maintenance, but still wants to benefit from their outdoor space. The level of input required by the homeowner or tenants once an artificial lawn is laid is next to nothing and has the added bonus



How do you prepare your garden/lawn?

“The first step in laying your new artificial grass is to correctly prepare the ground so that it is ready for its new surface. This can be done with either a spade or turf cutter, though we recommend the mechanical option for new beginners as it saves both time and effort to make the process more enjoyable.

“To do this, the current lawn needs to be removed to a depth of at least 50mm, removing any large stones, bricks, or extra foliage that has remained as these will prevent a flat base being created for the new artificial grass.

“Once that is done a perimeter needs to be installed around the area the grass is going to cover. Walls and any other natural borders can

be utilised, with pressure treated timber ideal for placing around the exposed edges with approximately raised 30mm above the surface of the soil.

“Now that is in place the area can be levelled and compacted so that the grass can be laid. This can be completed using a wacker plate. The levelled ground is then ready for its drainage layer, and after that the membrane to prevent weeds, and finally the artificial grass.”

How do you choose the right turf?

“Speaking to a professional either in person or online is always the best way to determine the right artificial lawn for you, even if only for advice. They can provide the knowledge and analysis that will help you make the right decision as there are a variety of different grasses suited to varying needs such as play areas or golfing greens.”

Are there any disadvantages or things to look for?

“Improper installation may cause issues, however this can easily be negated and avoided by speaking with experts such as ours at PermaLawn.”



TREE RELOCATION: PRESERVING NATURE'S BEAUTY FOR FUTURE GENERATIONS



Since 1963, Civic Trees have been at the forefront of tree relocation throughout the UK, from importing the very first Vermeer tree spade into Europe, to designing and constructing the Newman Frame which is now used worldwide.

Civic Trees are always looking to pioneer new techniques that aid the relocation of trees.

Tree relocation is a concept that involves uprooting trees from one location and transplanting them to another. With current events surrounding environmental issues, relocating trees is even more important now than ever before. By relocating trees instead of cutting them down, we can preserve nature's beauty while also promoting sustainability.

We are proud of our reputation for efficient, cost effective and reliable tree relocation throughout the UK. You can be confident that through our exemplary commitment to staff



training and development, our work meets the highest technical and safety standards.

We believe that a tree is only as good as the way it is handled, planted and maintained. Ground preparation and aftercare are crucial to the successful establishment of the tree.

Before we start the tree move process we arrange a site visit with our client and assess the tree's health, size, and root system. We also create a site specific risk assessment to ensure the whole operation is carried out safely.

Our team of experts use specialised equipment to excavate the tree with minimal damage to its root structure. The tree is then carefully transported to its new location,

where it is replanted and nurtured to ensure its successful adaptation.

Our experienced team will know and understand the benefits and methods of loading and unloading a tree using the correct lifting techniques in order not to stress the tree or root ball. This is imperative for the longevity of the tree's life.

In conclusion, tree relocation is an environmentally friendly method that allows us to preserve nature's beauty while supporting urban growth. By carefully uprooting and relocating trees, we can maintain the valuable benefits they provide to our communities.

Civic Trees prides itself in paying great attention to the health and well being of our clients most prized asset "THE TREE".



Supply. Plant. Relocate.



Visit: www.civictrees.co.uk
Email: info@civictrees.co.uk
Tel: 0208 950 4491





REINVENT YOUR OUTDOOR SPACE

Turn neglected weedy patches into stylish, statement areas with UltraScape's brand new product range. Comprising of bedding, priming and jointing, this range of products are set to revolutionise all future domestic landscaping works.

Ever since the pandemic, there has been a huge upturn in homeowners investing in their gardens. Even with lockdown firmly in the rear-view mirror, we have continued to take pride in our outdoor spaces turning them into beautiful areas to host friends and family.

You can't build a great building on a weak foundation and the same is true about laying new paving. Create a solid foundation so future generations can enjoy your hard work by using UltraScape prebed mortar and prem-prime slurry primer on your next project.

Designed for bases commonly found in domestic gardens, prebed mortar and prem-prime slurry primer are incredibly easy to mix and apply and require minimal tools to install. With the paving laid, choosing the perfect finish is fundamental for the style and integrity of your paving installation. With three jointing solutions available, there is a grout perfectly suited to all types of stone, tastes and aesthetics.

UltraScape premjoint is an all-weather brush-in sand available in four stunning colours to match popular stone options. Porcelain paving continues to dominate popular landscaping trends. Leave homeowners in awe of your work by choosing UltraScape porcelpoint flowable grout for your next porcelain job. Completing the range is flowpoint fine - a flowable grout that has been transforming

landscapes for over 25 years. With just a neoprene squeegee or broom needed to install premjoint, porcelpoint and flowpoint fine, UltraScape's jointing solutions make light work of grouting pavers but are guaranteed to result in a dramatic transformation.

So, if you're working on improvements to a garden, UltraScape's new product range is the perfect way to do it. With a wide range of different styles and applications at your disposal, the world's your oyster when it comes to outdoor spaces.

To find out more please visit ultrascape.co.uk. For pricing enquiries, stockist information, or to place an order, please contact UltraScape's team of paving experts by emailing ultrascape@instarmac.co.uk or calling +44 (0) 1827 254402



Coming to a garden near you

Turn neglected weedy patches into stylish, statement areas with UltraScape's brand new product range. With a wide range of different styles and applications at your disposal, the world's your oyster when it comes to outdoor spaces.

NEW TO THE RANGE

PorcelPoint

Pointing perfection for porcelain



SET TIME:
15 MINUTES



OPEN TO FOOT
TRAFFIC: 1 HOUR



JOINT WIDTHS:
2-50MM



AVAILABLE IN
STONE GREY &
LIMESTONE



PremBed Mortar

Fibre modified bedding mortar



EASY TO
USE



LIGHT FOOT
TRAFFIC: 12 HOURS



DEPTH:
30-100MM



SUITABLE FOR
PORCELAIN AND
NATURAL STONE

JM CLARK
OPERATED PLANT HIRE

0800 014 6241
info@jmclarkltd.co.uk
www.jmclarkltd.co.uk

SCAN FOR MORE

MOTORSPORT AWARDS 2023
WINNER
BEST USE OF TECHNOLOGY AWARD

MECHANICAL ROAD SWEEPING
ROAD LINING
OBSTRUCTIVE VEHICLE REMOVAL
BITUMEN SPRAYING

FORS CHAS mpqc Constructionline Avetta FESTA

MAKITA LAUNCHES NEW BATTERY POWERED BRUSHLESS BLOWER

Makita has launched the UB003C 36V Blower that is the perfect companion for grounds maintenance professionals.

The new UB003C offers an average blowing force of 24N, a maximum air volume 17.6m³ per second, and air velocity up to 86m per second. For clearing large areas, this machine can provide a continuous run time of up to 60 minutes from a single charge.



This is made possible by attaching Makita's backpack battery system to the machine, for all-day work and performance without the hassle of using petrol or power cables. Specifically, rather than conventional batteries, the UB003C can either be connected to either the PDC1200 (33.5Ah) or PDC1500 (43.5Ah) Portable Power Packs as part of the manufacturer's ConnectX system, or to Makita's PDC01 battery backpack (all sold separately).

Find out more at www.makita.co.uk



ECO CLIPPER®

Efficient electric mowing systems for maintaining large area turfgrass

Eco Clipper FM4 Sport, 411 cm mowing width

NEW!
Eco Clipper FM343
343 cm mowing width
www.ecoclipper.com

POWERFUL PERFORMANCE WITH MAKITA'S CORDLESS POWER WASHER



The new 40VMax HW001G XGT Brushless High Pressure Washer from Makita offers a powerful performance akin to corded washers, with a maximum permissible pressure of 11.5 MPa. Three operational modes allow users to control the pressure depending on the task at hand - from light washing to the toughest clean.

When fully charged, the washer can be used for up to 60 minutes (in Mode 1) and can perform with just one battery or with two in parallel, allowing users to keep working even when one of the batteries needs charging.

The HW001G is self-priming, and water can be supplied from a tap, bucket or tank. The trigger lock function also keeps the water running without needing to be constantly squeezed.

Weighing only 8.5kg, a telescopic handle allows the height to be adjusted to 520mm. With large 140mm wheels, it is also easy to transport and manoeuvre, even on difficult terrain.

Find out more at www.makita.co.uk





STIHL

GET IT DONE WITH BATTERY.



Experience unprecedented performance with STIHL's extensive range of professional grade battery-powered tools for commercial users.

IPX4 certification lets you continue working with confidence in the rain. Long-lasting smart batteries deliver consistent power throughout the whole battery charge. And fast chargers deliver quick recharge times so you and your tools are always ready for the job.

FSA 200 BRUSHCUTTER

FIND OUT MORE AT [STIHL.CO.UK](https://www.stihl.co.uk)



APIII
SYSTEM

BEHIND THE SCENES - THE RIGOROUS SAFETY TESTING OF TRIMAX MOWERS UNVEILED

In the dynamic landscape of turf maintenance, where the wheels of progress are in perpetual motion, the unsung hero is often overlooked. Picture this: the hum of machinery, the scent of hard work in the air, and the collective pulse of an industry beating with ambition. Yet, beneath this bustling surface lies a crucial undercurrent - a commitment to uncompromising safety.

For Trimax, world leader in flail and rotary cutting equipment, safety isn't just a tick box exercise.

"From the design and development of our machines to the testing and manufacturing processes, safety is always at the forefront of our minds. We believe that by prioritising safety, we can not only protect operators but also enhance their productivity and efficiency."



Caroline Shaw, Global Brand Manager at Trimax.

Here we've got an exclusive, behind the scenes look at the meticulous safety testing that every Trimax machine undergoes before it hits the market!

Thrown Object Testing

When cutting grass, mowers can come into contact with foreign objects like stones, sticks, and golf balls. When mowers come into contact with them, there is a danger that the struck object may be thrown and cause injury to the operator or any bystanders.

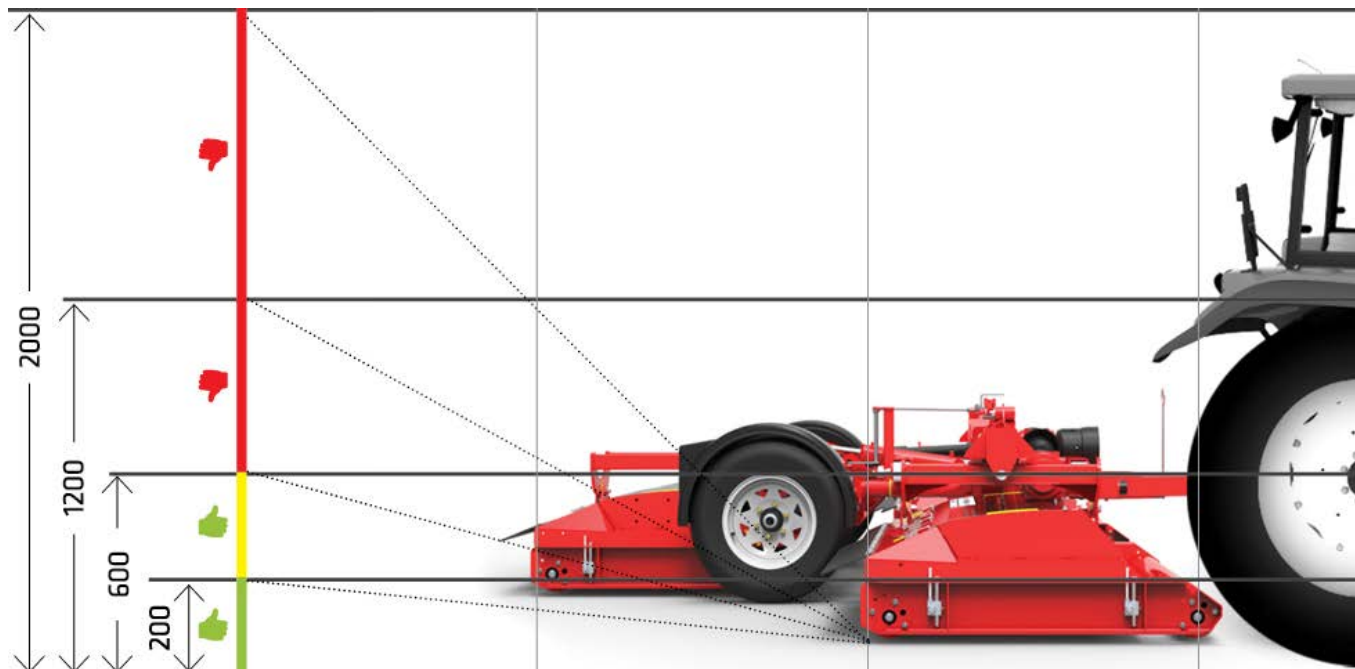



The thrown object test looks at how and where objects are dispersed. During the test, the machine is surrounded by specified targets and will run over sand and stones. To pass the test, no object can be thrown to the side or in the operator area, and only low impacts in the discharge area are acceptable.

Blade Impact Testing

Although Trimax blades are designed and made with durability in mind, in the event of a blade breakage, it must not fall in an unsafe way.

During testing, the mower is surrounded by targets. While the blades are moving, the mower is lowered onto a high-tensile steel bar.

To pass the blade impact test, there must be no loss of any part of the mower, and the targets must not be punctured by blades or any other part of the mower weighing more than 30g.

The purpose of this test is to ensure that if any part of the cutting system fails or comes into contact with anything that could cause damage, there is no hazard to the operator or anyone nearby.

Designing and Testing for Finger and Limb Safety

Due to the nature of a mower, it's imperative that fingers or limbs cannot get close to the blades, especially while in motion. For this reason, every hazard zone/ opening to moving parts has been carefully considered by Trimax, ensuring maximum safety.

Testing for Foot Access to the Cutting Chamber

Another important test is foot access. During testing, Trimax probes the cutting chamber with a dummy foot to evaluate the level of access around the machine, this ensures maximum protection for both the operator and any bystanders.

Trimax Mowers: Safer By Design

When it comes to safety, Trimax is setting the standard. Their uncompromising safety measures, extensive testing, and innovative safety features are what set them apart from the competition.

To find out more about the safety or testing of Trimax mowers, call 01933 652235 or visit www.trimaxmowers.co.uk

THE SUSTAINABLE SOLUTION: KRESS RTKN ROBOTIC MOWERS



Revolutionising Turf Care for Landscapers

With Kress RTKn mowers, Kress showcases the pinnacle of possibilities in automated mowing. These mowers integrate advanced technologies such as RTKn (Real-time kinematic to the power of network), MAP (Mowing Action Plan), and OAS (Obstacle Avoidance System) with new innovations, setting a new benchmark for performance and precision in turf care.

Key Features and Technologies

RTKn Technology: The Kress RTKn

mowers utilise a real-time kinematic network, eliminating the need for traditional powered antennas. This innovation not only makes the system immune to power surge damages, enhancing its reliability and resilience, but also avoids the extra costs and eyesores associated with line-of-sight aerials, this ensures the aesthetic and beauty of the landscape are preserved.

Mowing Action Plan (MAP): This feature optimises the mowing pattern for efficiency, ensuring complete and systematic coverage of the area.

Obstacle Avoidance System (OAS):

Advanced sensors and algorithms enable the mower to detect and navigate around obstacles, minimising the risk of damage and ensuring uninterrupted operation.

Slope Handling:

Kress mowers excel on sloped areas, showcasing their exceptional performance even on uneven terrain. They are engineered to manage slopes of up to 20 degrees effortlessly, ensuring consistent and even mowing. This superior slope-handling ability sets Kress mowers apart, making them an ideal choice for landscapers and groundskeepers seeking robust and versatile mowing solutions.

Unmanned Mowing:

Significantly decreases labour costs and reduces energy bills.

Maintenance Savings:

The durability and advanced technology reduce maintenance expenses.

Health and Environmental

Benefits: These mowers provide a quiet, emission-free alternative to traditional mowing methods, contributing to a healthier environment and sustainability goals. Switching from petrol mowers to Kress RTKn robotic mowers will significantly reduce your carbon footprint and offer a greener, more sustainable maintenance solution.

Investment Worthy:

The operational savings and health benefits provided by Kress RTKn make it a smart investment for any landscaper or groundskeeper. The efficiency, reliability, and technological advancements set a new standard in commercial turf care.



For more information, visit the Kress website: kress.com/en-gb/rtkn-without-boundary-wire.

THE FUTURE OF UNMANNED MOWING IS NOW.

The Kress RTKⁿ robot mowers extend unmanned mowing to larger areas. They efficiently operate in parallel lines and autonomously move from one area to another, as if driven by humans. There is no need for boundary wires or on-site aerials. The Kress RTKⁿ robot mowers maintain areas of up to 36,000 m² each.

RTKⁿ

Real-time kinematic to the
power of network



Kress[®]

Speak to your local garden machinery dealer today to learn more.

[kress.com](https://www.kress.com)



PERFECT PITCHES

CHAMPION WIEDENMANN TERRA SPIKE XF FOR CRICKET MAINTENANCE

Family-owned contractor, Perfect Pitches of Grantham, Lincolnshire, are long time advocates of the Wiedenmann Terra Spike XF.

Indeed, Director, Keith Exton and his son, Alex, go as far as saying it is the only deep aerator on the market that can get the depth without damaging the surface in the harsh cricket square environment.

Perfect Pitches have an established reputation for first-rate care and attention, whether it be for one of their blue-chip clients like Lords, the Oval, Trent Bridge or work with the smallest village clubs.

Keith always partners their Wiedenmann XF, with a trusty John Deere 3720 on Galaxy turf tyres, for autumnal cricket square Terra Spiking,

“Every square is different. However, correct set up is essential. The forward speed of the XF is much quicker than any other deep aerator on the market. Crucially, it’s the tine striking action - due to the belt driven balanced crank shaft - on the XF that fires the tine into the ground so rapidly that makes the difference. It does not seem to hang on to the tines when they come out, so you don’t get ‘lift’, everything is clean,

precise and tidy. That’s what makes it fantastic.

“We must be doing something right as we keep getting the invitation to return year on year,” said Keith.

**For more information contact
Wiedenmann UK 0141 814 3366 or
info@wiedenmann.co.uk & Premier
Pitches 07801 814450**



M18 FUEL

Nothing but **HEAVY DUTY.**[™]

MILWAUKEE® EXPANDS THEIR M18 FUEL “QUIK-LOK™ ATTACHMENT SYSTEM

MILWAUKEE® continues their commitment to drive productivity and versatility for the landscaping and trade professional, with the expansion of the M18 FUEL™ QUIK-LOK™ Attachment System.



“The M18 FUEL™ QUIK-LOK™ Attachment System provides ultimate versatility to complete a wide range of applications.”

ACHIEVING INSTANTANEOUS THROTTLE RESPONSE WHILE MAINTAINING A LIGHTWEIGHT AND ERGONOMIC DESIGN, OPERATORS ARE PROVIDED WITH IMPROVED PRODUCTIVITY AND VERSATILITY ON THE JOB.

Now consisting of over ten attachments and offering year-round application versatility, the M18 FUEL™ Outdoor Power Head with QUIK-LOK™ is compatible with a new cultivator, reciprocator, hedge trimmer, and blower.

RE-FLOW AND GROUNDSFEST – VISIT US AT THE SHOW



Landscape managers require their field management software to:

- give real-time visibility of jobs, documents, and workflow operations.
- provide forms for evidencing work – forms so easy to use that operatives feel more compliant and process driven.

Re-flow is a cloud-based field management solution that provides worker qualification libraries, asset scheduling, job progress, photo uploads, in app communication and much more...

A Case in Point

Re-flow landscaping client, Shines Environmental, chose us as their field management solution during a time when they were operating on a number of siloed digital systems. They also wanted access to high-quality data and job information. A major goal was making photographic evidence a mandatory part of form submission, with tags linking the pictures back to the relevant job and operative.

Shines Environmental adopted the system and rolled it out throughout their business. The software has

given administrative teams total control over job planning and operative deployment while providing a complete history of all works.

There have been other bonuses too:

- Revolutionised health and safety data capture and plant, vehicle, and equipment auditing, leading to an 80% increase in auditability.
- No more workers waiting around for instructions and paper job sheets in the morning.
- Instead, with digital job information, they now have access to a central knowledge base and the ability to instantly receive messages through the app, keeping them up to date and informed.
- Streamlining processes causing an increase in available time by 25% and improvement in cross-team communication by 60%.

Equal to visiting our website, the best way to learn about the power of Re-flow is to see it in person. We're excited to be attending this year's GroundsFest to show off our software, and we invite you along to Hall 1, Stand 31 to talk to our show team...

The team are experts at listening to your particular concerns and the specific operational challenges of your business. They'll show you what the software can do, and list the many ways that Re-flow can be configured to fit your specific needs.



www.re-flow.co.uk

**DO YOU KNOW
WHERE YOUR
OPERATIVES
ARE TODAY?**



RE-FLOW DOES

Re-flow[®]
Field Management

Field management software that puts
you in control and your team to work

Call 01392 547002

Visit www.re-flow.co.uk



INFINICUT® FL22 PROVES TO BE A SILVER LINING DURING PROLONGED RAINFALL FOR STANEDGE GOLF CLUB



An INFINICUT®FL22 was purchased by the team at Stanedge Golf Club to equip the Derbyshire venue with a mowing solution for periods of wet weather... and in reality, its delivery in the autumn of 2023 could not have been more timely! The prolonged and persistent rainfall has seen Head Greenkeeper Lee Williams and his team turning to the INFINICUT® to maintain HOC and presentation while the triple green mowers are resigned to sheltering in the shed.

Located in the picturesque Peak District, the moorland/parkland course like many has seen unprecedented rainfall levels over the last six months. "With no ability to control what mother nature throws at us, all we can do is equip ourselves with the tools and techniques to be able to deliver surfaces no matter the weather" explains Lee, who took over as Head Greenkeeper two years ago. "We knew that we needed to look at hand mowers and spoke to our local dealer Balmers GM about the options

available. We trialled the INFINICUT® and were sold straight away! The quality of cut was unbelievable, like nothing we'd ever used before."

The floating-head FL22 forms part of the INFINICUT® golf range, designed to deliver the ultimate precision for fine-turf surfaces. Engineered to suit the specific set of requirements needed for modern golf-course maintenance, the FL22 is equipped with INFINICUT's SMARTCut™ cylinder reels, produced in-house and dynamically balanced for unbeatable accuracy.

"On top of the quality of finish, the fact that the INFINICUT® is battery-powered has been another big plus-point for us. While it wasn't a necessity initially, we have now all-but eliminated issues with noise and vibration levels, as well as saving ourselves money on fuel." Lee continues, "John Hobbs at Balmers was excellent at getting us all set up, including showing us the many features of the INFINIApp which we've been enjoying using and is just another thing that makes the INFINICUT® stand out from the competition."

At the time of writing, Lee explained that softer ground conditions had seen the club unable to use the triple green mowers this year to date. "The fact we've been able to get out twice weekly and in any breaks between showers with the INFINICUT® has been critical. I'd love to be able to hand mow year-round but with such a small team we are limited by our resources, however, should we be able to go down that road it would be an INFINICUT® fleet without doubt!"

[infinicut.com](https://www.infinicut.com)

THE BEFORE AND AFTER OF ONE METRE DEEP AERATION

COMPACTION AND WATERLOGGING STOP PLAY. DOWNTIME COSTS MONEY.

Terrain Aeration's long-term treatment reaches one metre deep where compressed air blasts the compaction.

The soil is opened up for good drainage and a healthy sward with minimum disruption.

We have been successfully aerating sports turf, bowling greens, golf courses, parks, trees and gardens for over twenty-five years.



See us at work:

www.terrainaeration.co.uk

Call us for a quotation 01449 673 783



 **screwSHOP**.co.uk

DIY • Trade • Business

"Let us surprise you - Lowest Online Prices"



- Ironmongery & Builders Metalwork
- Silicones/ Sealants
- PPE
- Lowest Prices
- Next Day Delivery throughout the UK



Home of **TURBOQWIK** and **RHINO**
THE PRECISION MULTIPURPOSE WOODSCREW SCREWS

0121 559 8866 • sales@screwshop.co.uk



FLOURISH PAVILION

BY STUDIO A-LIGHT

In the greenhouse, where sunlight and moisture converge, emerges a sacred space for the growth of flowers and crops. Inspired by the everyday scenery of agricultural greenhouses in Changhua, Taiwan, "Flourish" features a bamboo-

structured dome. This artwork utilizes agricultural materials such as bamboo and agricultural mesh, aiming to showcase the vitality of blooming flowers through modern geometric structures. The interior of the dome presents a variety of

spaces, including large floral floating islands, greenhouse mist irrigation systems, original electronic music, and projection art, intending to bring a vibrant new atmosphere of spring to the public.



The bamboo dome of “Flourish” is constructed using heat-treated bamboo pipes and metal joints, supporting a colossal dome measuring 9 meters in height and 23 meters in length and width. The structure primarily employs thicker-diameter Moso bamboo as columns and beams, while thinner, heat-treated Makino Bamboo is pre-stressed and curved to form arches, serving as structural braces and artistic expressions for the agricultural film. Three large floral floating islands, suspended in the

center of the dome and collectively weighing 400 kilograms, act as a means to reduce wind forces and stabilize the overall structural system. Bamboo and custom-made metal joints are meticulously installed layer by layer, following pre-set patterns, enhancing the precision of the bamboo structure construction.

Bamboo is primarily found in warm regions between the Earth’s north and south latitudes of 45 degrees, and it is a common material in

Taiwanese forests. After undergoing high-temperature drying treatment, bamboo exhibits axial strength reaching up to 70% of that of hardwood. The presence of bamboo nodes in the middle contributes to the superior toughness of bamboo. The goal of Studio A-Light’s creation is to explore how to rapidly utilize prefabricated bamboo components in the construction of modern building materials while simultaneously showcasing the unique and elegant forms of bamboo.



Architects: Studio A-Light

Area: 415 m²

Year: 2024

Photographs: Fixer Photographic Studio

Manufacturers: MIT-LIGHTING, Yueshan

Lead Architect: Bo Chun Lee

Landscape Architects: flowers juang

GREEN-TECH SUPPLIES PRODUCTS FOR FLINTSHIRE COUNTY COUNCIL AIR QUALITY MONITORING PROJECT

Leading landscape supplier Green-tech has recently collaborated with Flintshire County Council on an environmental initiative aimed at monitoring and improving the air quality at Ysgol Croes Atti Primary School.

Project Overview

The Primary School is located within an urban area of Shotton, North Wales with busy roads close by. The project involved the installation of living green screens to mitigate air pollution and enhance green spaces within the school grounds. After reading a study on how living screens can absorb particulate matter emitted from vehicles, Flintshire County Council decided it would be a worthwhile investment to help create more green space within an urban area whilst simultaneously helping capture particulate matter within the living screens.

The Air Quality Monitoring Project at Ysgol Croes Atti was initiated in response to concerns about air pollutants emitted from nearby busy roads. The project aims to create a greener environment while capturing and reducing airborne pollutants.

Green-tech's Involvement

Green-tech was chosen due to their extensive experience regarding projects like this one, having completed similar projects for other local counties with great success.

For this project, Green-tech supplied a comprehensive range of products, including:

- 45 Hedra Helix Woerner Ivy Screens, designed to absorb particulate matter and other pollutants.
- 45 Bespoke Green Screen Planters, available in any RAL



K7 classic colour, in polished, matt, textured matt, and natural finishes adding aesthetic value to the project.

- 45 Mona Tanks, supplying irrigation which is essential for maintaining the health and growth of the ivy screens.
- 16 Bulk Bags of Green-tree Topsoil, high-quality topsoil to ensure optimal plant growth.

Project Implementation and Data Collection

Wildbanks Conservation, a leading organisation in practical conservation, ecology, and environmental education, installed the green screens for this project that followed a rigorous approach:

1. Baseline Data Collection: Before the green screen installation, three months of air quality data was collected to establish baseline levels of particulate matter and other pollutants.
2. Installation of Living Screens: The living screens were installed across the gated area of the school, creating a green barrier.
3. Post-Installation Data Collection: After installation, further data will be collected and compared to the

baseline data to assess the impact of the green screens on air quality.

The Outcome

Flintshire County Council anticipates that the post-installation test data will show reduced air pollutants on the school grounds. This data will be crucial in determining the effectiveness of the green screens in reducing air pollutants on the school grounds. The project at Ysgol Croes Atti aims to improve air quality and serve as a model for integrating green infrastructure in urban educational settings.

Green-tech's Account Manager James Renfrew comments, "Green-tech's involvement in the Ysgol Croes Atti Green Screen Project highlights the importance of using innovative solutions to address urban environmental challenges. By combining practical conservation efforts with advanced air quality monitoring, this project aims to create healthier and greener school environments."



Helping to transform landscapes for 30 years

Green-tech is proud to work with landscape contractors, designers and architects to create beautiful, sustainable and biodiverse landscape projects, supplying the industry with everything from soil to stakes and tree shelters to topsoil.

- Over 10,000 products with a robust supply chain
- Nationwide, flexible and next day delivery options
- A comprehensive programme of CPD seminars and training seminars
- Renowned for our professional advice and excellent customer care

Order today by calling **01423 332100**
or order online at **www.green-tech.co.uk**

✉ sales@green-tech.co.uk ✉ [@greentechltd](https://www.instagram.com/greentechltd) [@greentechuk](https://www.facebook.com/greentechuk) [in green-tech-ltd](https://www.linkedin.com/company/green-tech-ltd)

All your landscape materials available from one company and on one delivery:

Urban Tree Planting and Tree Irrigation

Soils, Growing Media and Barks

Rural Tree Planting

Wildflower Seed and Conservation

Ecology, Ponds and Bioengineering

Ground, Wind, Weed and Erosion Control

Grounds Maintenance





CITY CLUSTERS

Butler Wiltshire has recently completed a series of seating and planter clusters for the City of London, made from terracotta and repurposed timber. The sculptural, tessellating modules have been designed to respond to the City's unique architectural heritage and provide much-needed pockets of

seating and greenery within the high-rise Eastern City district.

The geometry of the modular design derives from the Coats of Arms of the historic City Livery Companies, which are typically a 5-sided crest or shield. These symbols are synonymous with the

City and can be seen throughout the district, typically on buildings, gateways, and street furniture. From the archetypal shield motif, a subtly altered, tessellating tile geometry was developed. This was extruded to create vessels of six different heights, with the same basic form used to create both seats and planters.

As a counterpoint to the engineered glass and steel of the City towers, the materials used are natural, tactile, and hand-crafted. The bases are ceramic, a reference to the clay on which the City is built, with the distinctive terracotta color

taken from the Roman bricks and pottery found by archaeologists in the Bishopsgate, Fenchurch St, and Lime St areas. The bases were hand-produced by Darwen Terracotta, a specialist in architectural ceramics based in Blackburn.

The three lower modules form seating, with varying heights to cater to different access needs and individual ergonomics. The timber seat tops have been crafted by Fallen & Felled from repurposed fallen urban trees, sourced from within the confines of Greater London. A wide range of species, including oak, elm, yew, hornbeam, and sycamore, bring a variety of unique grains, colours and texture to each cluster.

The asymmetric nature of the pattern and variation in module heights produces a varied, organic language that avoids the appearance of clear repetition. It can be adapted to a multitude of different site sizes and conditions, allowing for endless reconfiguration, and the careful arrangement of the clusters can either emphasize an orthogonal pattern or generate softer undulating edges. The three taller modules are planters, filled with sculptural and seasonal planting.



Architects: Butler Wiltshire

Photographs: Butler Wiltshire - Ed Butler, Architectural Photography by Simon Kennedy

Manufacturers: Darwen Terracotta, Fallen & Felled

Lead Architects: Ed Butler, Daniel Wiltshire

FRAMING

THE VIEW

75 years is just the beginning... At HAGS, the emphasis on sustainability has guided our efforts over the last 75 years.

Even though the concept of "sustainability" might not have been as prevalent in the past, our genuine concern for both the environment and people has always been a driving force.

As a company, we hold the responsibility of ensuring that our operations remain sustainable from economic, social, and ecological standpoints.

We have teamed up with some of the most renowned Scandinavian designers to develop a range of park and Urban Furniture products encouraging the local community to socialise and enjoy spending time outdoors.



Boasting a timeless aesthetic and improved usability, our park and urban furniture range will cope with heavy use and age beautifully over the years. Suitable for all weather conditions and environments, it has added value to many outdoor recreational spaces across the world.

As a global pioneer in designing outdoor recreational equipment, we specialize in crafting innovative park furnishings that transform areas into vibrant outdoor havens.

Embark on a journey where innovation meets purpose, and every structure tells a story of community, fun, and fitness.

Whether you're on the lookout for the perfect accent for your project or require guidance to embark on a new initiative, explore our 'Crafting Outdoor Spaces' section for a roadmap into the world of HAGS equipment. From designing your own seating area HAGS have you covered. Discover more <https://hags.co.uk/en-gb/furniture>



OUTDOOR PARK AND
URBAN FURNITURE





INNOVATIVE GARDEN PATHWAYS: ENHANCING AESTHETICS AND FUNCTIONALITY WITH RESIN BOUND SOLUTIONS

Choosing a resin-bound finish for your garden pathway could be the ideal solution if you are looking to enhance the exterior of your property with a method that is both durable and low maintenance.

Below, John Pearce, Co-Director at Oltco, an award-winning supplier and installer of sustainable resin bound driveways, patios and pathways, discusses just how a resin garden pathway can improve

the aesthetics of the outside of your home, while also increasing functionality.

Smooth and Seamless

Uneven slabs on garden footpaths



bound pathway can be easily cleaned in order to maintain the fresh aesthetic of the pathway allowing spills to be quickly removed with a jet wash. The properties of a resin bound pathway also mean that the surface minimises weed growth in comparison to other flooring solutions so looks fresh all year round. This low maintenance nature makes resin bound pathways an excellent choice for busy homeowners.

Matching Aesthetics

Oltco's resin bound solutions are available in a range of colours and can be created in any shape or pattern to suit your property style and personal preferences. For many of our clients at Oltco, customers are looking for a garden pathway that matches the aesthetics of their homes, and to match their resin bound driveways. The flexibility in design means your pathway can be as unique as your home.

We have also recently launched four brand new colour blends, created by our own in-house team, available in resin-bound and our innovative Recycle Bound solution, made using a mix of stone and aggregates as well as recycled waste plastic. These new blends offer even more options for personalisation, ensuring that your pathway can be a true reflection of your style.

Long Life Span

Resin bound surfaces are resilient and often last up to 25 years or more, making them a cost-effective and environmentally friendly alternative to concrete pathways. At Oltco we offer up to 20-year guarantee to all resin bound footpath customers, alongside detailed aftercare advice in order to ensure the pathway looks fresh for many years to come. This longevity and support provide peace of mind and great value for your investment.

Oltco is available across the UK, and is the country's leading sustainable resin bound flooring company offering solutions for driveways, pool surrounds, balconies, patios, stairs, car parks and footpaths.

can not only be dangerous to walk across but can also look untidy and uncared-for. Resin bound pathways are seamless and have anti-slip properties, making them practical and safe for walking on, as well as DDA compliant and accessible with wheelchairs, pushchairs and bicycles. This seamless finish ensures a modern and polished look for your garden.

Easy to Maintain

Resin bound pathways are low maintenance and permeable, meaning that any water that lands on the pathway will be quickly drained away. Additionally, a resin

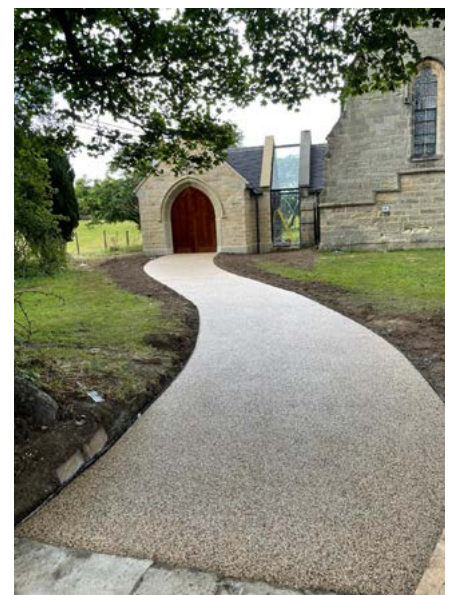
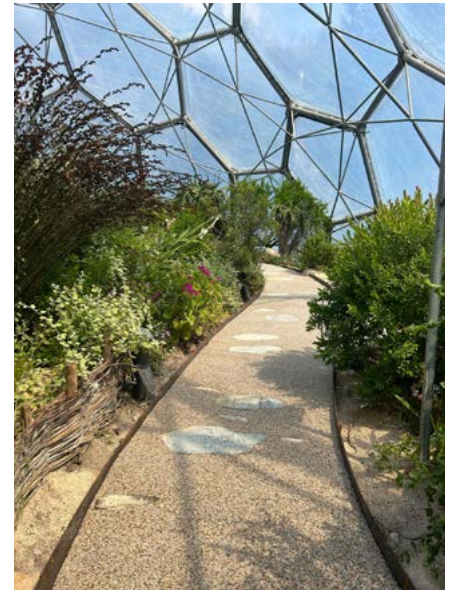

To arrange a free home visit call 0800 040 7795 or visit www.oltco.co.uk/request-home-visit

STONE & PORCELAIN SUPPLIES



With a reputation carved out from a combination of quality porcelain and naturally sourced stone paving, walling and associated products Stone & Porcelain Supplies redefines how stockists can access the best paving products while enjoying excellent prices achieved by its international buying power. With a focus on customer care, product choice and huge stocks, read why you should be speaking to Stone Paving Supplies.

A Commitment to Quality and Affordability

Stone & Porcelain Supplies has built a solid reputation in the industry by consistently delivering high-quality products at affordable prices.

The company imports a wide range of natural stone and porcelain paving, ensuring customers can access the finest materials at amazing prices. Whether it's the timeless beauty of sandstone or the sleek, modern appeal of porcelain, Stone & Porcelain Supplies caters to diverse tastes and project requirements.

Porcelain Paving

Porcelain paving has gained popularity in recent years due to its sleek appearance and practical benefits. Stone & Porcelain Supplies offers an impressive range of porcelain options that mimic the look of natural stone while providing superior performance.

Natural Stone Paving

Natural stone paving is prized for its unique, organic beauty and durability. Stone & Porcelain Supplies offers several types of natural stone, each with its own distinct characteristics.

Exceptional Customer Service

Stone & Porcelain Supplies prides itself on its customer-centric approach. The company's knowledgeable staff are always on hand to provide expert advice and guidance, helping customers choose the right products for their needs and servicing their accounts.

Every stockist account has an experienced account manager to service enquiries and keep you fully informed.

Competitive Pricing

In addition to quality and variety, affordability is a crucial focus for Stone Paving Supplies. The company's strong relationships with quarries and manufacturers enable it to negotiate favourable prices, which are passed on to customers. This ensures that high-quality paving is accessible to a wide range of budgets without compromising quality.

Explore their extensive range and experience the difference that quality, affordable paving can make to your business.

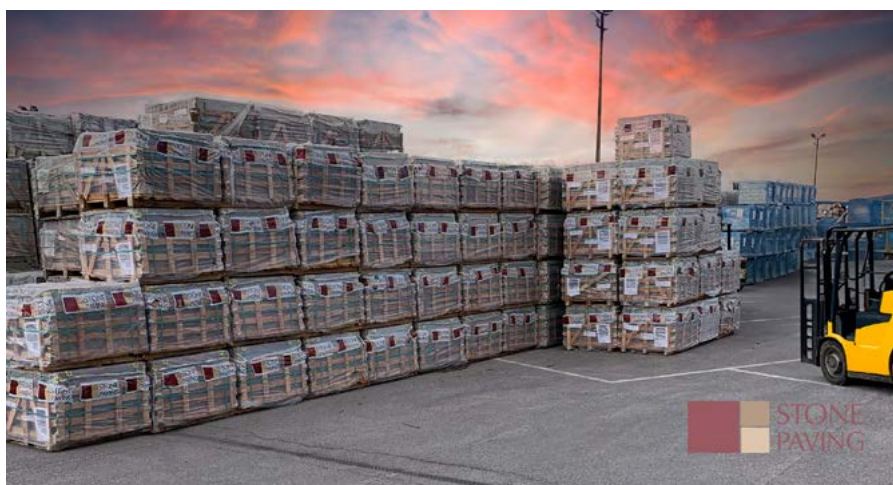

Speak to us today to see how we can help your business call 0333 600 4567 or email sales@stonepavingsupplies.co.uk



Prices from £9.95m² Mammoth choice Huge stocks

Welcome to Stone & Porcelain Supplies, your premier destination for top-quality landscaping products.

As a leading supplier dedicated to serving builders merchants and landscape centres, we pride ourselves on offering an extensive range of stone and porcelain solutions that cater to every need.

Contact us today for July's special offers!



0333 600 4567
sales@stonepavingsupplies.co.uk
stonepavingsupplies.co.uk



GETTING THE BEST RETURN ON NEW BUILD HOUSING DEVELOPMENTS



When people look to buy a new build house, it's not just the house they look at.

Subconsciously, design and development exclusivity are examined and consciously, the parking, garden, room sizes, local amenities, public areas, housing prices are observed, according to a recent Which report.

Launching Verti-Crete fencing this year, Paul Cartwright, Business Development Director at Elite Precast Concrete knew the product had to serve the needs of housebuilders, as well as homeowners, which is why the concrete fencing product is decorative, cost effective, long lasting and low maintenance.



With boundary, acoustic or security fencing needed for most developments, the easy to install, cost-effective, decorative fencing system serves the purposes of all stakeholders.

If fencing falls into disrepair within 5 years, the housebuilder is usually blamed, Paul says, "housebuilders can get a bad name for cutting corners during specification, resulting in cheaper developments, which are bad for the environment and may be dangerous."

"Cheap materials and poor installation can attract vandalism and reflect on house prices, resulting in replacements and repairs, with materials going to landfill and unhappy homeowners."

"Installing secure fencing can prevent damage to the area, increasing property demand and value, reducing homebuyer complaints and development costs and boosting the reputation of the housebuilder."

Paul goes on to say, "we knew we wanted to develop a fencing solution that would be approved for use by housebuilders, landscapers and architects and Verti-Crete answered the requirements they had."

"Available with decorative finishes on both sides of the fencing, Verti-Crete offers savings in time and money and can give a development a complete project look. The 'hollow core' posts are placed over individual footings with rebar anchors, the wall panels are then inserted, and only when each section is squared and levelled are the posts filled with concrete. This secures the connection between the post and footing and allows for a more levelled, stable fence system."

"Made from precast concrete, the Verti-Crete fence system weathers far better than wood or vinyl fencing and will not dent, corrode or be subject to weathering from the sun, making it perfect for landscaping projects and housing developments".

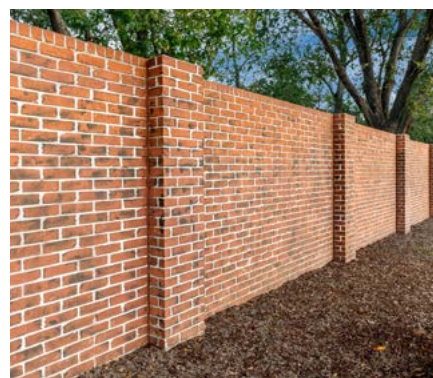

For more information on Elite's Verti-Crete fencing and walling system please visit www.eliteprecast.co.uk/concrete-fencing-products/verti-crete-walling-and-fencing/



Verti-Crete Fencing & Walling System



Secure and Private



Effective Sound Barrier



Fast to Install



Design Flexibility



Cost Effective

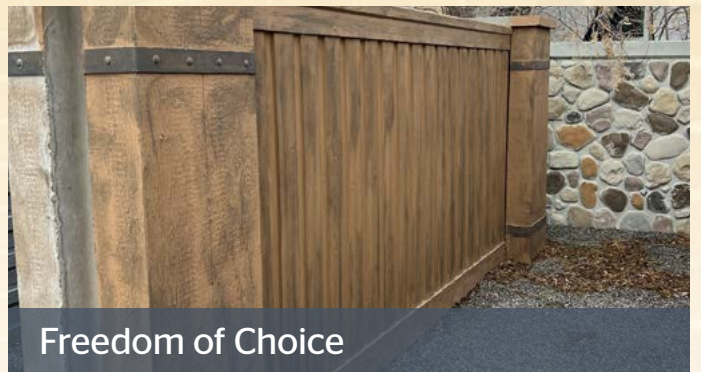

Freedom of Choice



Creating safer spaces with
fencing & walling solutions



For more information please call 01952 588 885
email sales@eliteprecast.co.uk or visit www.eliteprecast.co.uk



HILLS QUARRY PRODUCTS

As a key part of The Hills Group, Hills Quarry Products has continued to build on its 124-year history with further expansion across the south of England - including the opening of new ready mixed concrete plants in Swindon in Wiltshire and Wilmington in Devon. Hills Quarry Products has also future-proofed aggregate supplies with planning approval for its largest gravel quarry to date at Down Ampney in Gloucestershire.

With eight concrete plants, seven quarries and a large fleet of tippers and mixers, including mini-mix, Hills is perfectly placed to fulfil orders of concrete, specialist concretes, floor screeds, stone, gravel, sand and unique, decorative aggregates. Muck-away and haulage services complete the offering, with several licensed waste disposal sites available. Hills Quarry Products is an active member of the Mineral Products Association.

Visit us: hills-quarry.co.uk
 Contact us: info@hills-group.co.uk

Hills Quarry Products

Suppliers of aggregates and concrete for every need:

- ready-mixed concrete, including mini-mix delivery
- sand cement floor screed
- Cemfloor liquid screed
- decorative aggregate
- sand, gravel and stone

Telephone:
01793 714999

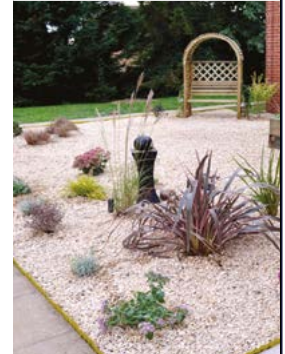

hills-quarry.co.uk



STONEMWORK

BESPOKE MASONRY SERVICES

STEPS | COPINGS | PIER CAPS | SCULPTURE
 PAVING | WALLING | ROCKERY | WATER FEATURES

01844 279274 | sales@stoneworld.co.uk | www.stoneworld.co.uk | Views Farm, Great Milton, OX44 7NV



EXTERNAL PAVING & TILING SOLUTIONS - BRINGING THE INSIDE OUT WITH FUSION XT!

Larsen Building Products is excited to launch the long-awaited new Fusion XT product range!



As a complete external paving and tiling solution, this range comprises five high-quality, high-performance products including three jointing compounds: Fine-Joint, Brush-Joint, and Flow-Joint Smooth, as well as Priming Slurry Bonding Mortar and Brick-Slip Bond Stone & Cladding Adhesive.

Paul Luff, Larsen Sales Manager (Tiling & Flooring Division), speaks of the new Fusion XT product range: "This is a super bucket range; perfect for DIY and retail, as it keeps everything clean and tidy. As specialists in external paving and tiling solutions, Larsen has created these buckets that detail all the key features and easy-to-follow instructions."

Contact: +44 (0) 28 9077 4000
 Website: LarsenBuildingProducts.com
 Social Media: [@LarsenBuildingProducts](https://www.instagram.com/LarsenBuildingProducts)

GEOfabrics®

CuTex
Copper Composite Root Barrier



UK Design &
Manufacture

Love Trees, Hate Roots?

Safeguard infrastructure with the proven permeable root barrier that's environmentally kind.

CuTex is a permeable geocomposite root barrier system, consisting of a specially formulated copper sheet encapsulated between two high-performance geotextiles. Developed and manufactured by GEOfabrics, a leading UK geosynthetics manufacturer.

- Permeable – maintains natural hydrology
- Safe & easy to install
- Enables biodiverse solutions
- Compatible with SUDs strategy
- Independently & scientifically assessed against numerous species

Find out how you can protect your assets from tree root damage – contact our team on 0113 202 5678 or visit www.geofabrics.com

UNIVERSITY OF LEEDS



RIBA
accredited
learning



PCA endorsed

SUDs > BREEM



TRANSFORM YOUR NEXT PATIO PROJECT

The Big Spin Hurricane levelling system is a game-changer for achieving flawless installations. This innovative 2-part system eliminates lippage (uneven tile surfaces) and ensures a perfectly level patio every time.

The Big Spin Hurricane system takes a unique approach to achieving a perfectly aligned and spaced tiling layout. Unlike traditional methods that rely solely on the installer's skill and meticulous adjustments, this system ensures tiles remain level throughout the adhesive curing process. This translates to a significant reduction in installation time and minimises the risk of errors that can lead to uneven surfaces. Once the adhesive dries completely, the caps can be effortlessly removed, revealing perfectly prepared tiles for grouting.

The Big Spin Hurricane system boasts four distinct base sizes, each colour-coded for easy identification based on the desired grout width.

- **3mm:** Ideal for use with porcelain epoxy grout, offering a clean and tight finish, particularly effective for achieving a minimalist aesthetic.

- **4mm & 5mm:** Popular options for standard grout applications, providing a touch of definition between tiles; allowing for slight adjustments during installation.
- **6mm:** Recently added to meet the BS7533-101 standard for porcelain paver installation, ensuring compliance for professional projects and guaranteeing a durable, long-lasting patio.

The system's ergonomic and user-friendly design prioritises comfort and ease of use, minimising fatigue during the tiling process. The specially constructed bases are designed for a clean break, leaving grout joints perfectly prepared for the final grouting stage, eliminating the need for additional scraping or cleaning.

The Big Spin Hurricane system revolutionises the patio-laying experience, transforming it into a more effortless and enjoyable process. With its emphasis on precision and ease of use, the Hurricane system eliminates the frustrations of uneven surfaces, allowing you to achieve seamless, professional results that elevate both residential and commercial projects.

This innovative tool empowers Tilers, Contractors, Landscapers, and even DIY enthusiasts to achieve superior results in their patio projects. By minimising installation time and reducing the risk of errors, the Big Spin Hurricane system translates to cost savings and a smoother overall project experience.

Embrace innovation and transform your next patio project with the Big Spin Hurricane levelling system. Experience the effortless precision and enjoy the satisfaction of creating a beautiful and durable outdoor space that will be the envy of your neighbourhood.



www.tilerite.co.uk



BIG SPIN HURRICANE

Levelling system for porcelain paving



WARNING: HURRICANE SEASON



3mm



4mm



5mm



6mm



TILE RITE
250 PCS
BIG SPIN DEEP
HURRICANE
5MM LEVEL BASES
SUITABLE FOR ALL HURRICANE CAPS

TILE RITE
100 PCS
BIG SPIN
HURRICANE
LEVEL CAPS
SUITABLE FOR ALL HURRICANE BASES

WARNING: HURRICANE SEASON



CLEAN BREAK

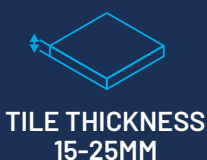

TILE THICKNESS
15-25MM



QUICK & EASY
TO USE



REUSABLE &
RECYCLABLE

Available in 4 different grout widths
colour coded for easy selection
3mm, 4mm, 5mm and now 6mm

Become a stockist: www.tilerite.co.uk

sales: sales@tilerite.co.uk

HIGH-QUALITY LIMESTONE

Cotswold Hill Stone and Masonry based near Cheltenham in Gloucestershire is well known for their Guiting form of limestone - extracted at their Cotswold Hill Quarry and is sought after by numerous different client sectors.

Their high-quality limestone features a fine texture in a pleasing creamy white or honey coloured appearance and is regularly used to produce or repair architectural features such as mullion windows or door surrounds, as well as supply building and walling stone to serve the new homes, commercial, restoration and refurbishment market.



They also boast a team of skilled stonemasons who work closely alongside their clients to bring their ideas to life whilst providing expert guidance.

Cotswold Hill Stone and Masonry also produce a Pennant sandstone from their Birch Hill Quarry, based in the Forest of Dean. The alluring blue and grey colour of Pennant Sandstone is popular among those seeking a more modern aesthetic as it can be used in all manner of applications, including construction, landscaping, revetment work and civil engineering. It is highly weather resistant and maintains its striking colours and

appearance generation after generation. It makes an eye-catching decorative feature, be it weathered or newly-quarried. One of its frequent uses is for the restoration or replacement of Regency building features such as steps and memorials. Birch Hill also produces an attractive cropped building, walling and paving stone regularly favoured by architects and planners.

To view their products visit their website www.stonequarries.co.uk, or to chat call 01386 584384.



LIMESTONE - SANDSTONE
BUILDING STONE - FLOORING - WALLING
MASONRY - LANDSCAPING - RESTORATION



01386 584384
www.stonequarries.co.uk





MAPEI EXTENDS LANDSCAPE CALENDAR WITH NEW MAPEPAVE

Mapei has launched MapePave - a new pre-blended ready-to-use mortar system for the fast installation of natural and engineered stone pavers externally, all year-round. Ideal for 20mm porcelain and natural stone, the new system provides normal setting and controlled shrinkage for fast-drying bedding and installation. When grouted with MapePave Brush in Grout, pavers can accept foot traffic after 24 hours.

The new MapePave line comprises of three products:

MapePave Slurry - a single component water mixed bonding slurry - which is applied to the backs of pavers or tiles. The slurry enables the monolithic bonding method of installation to a bed of fresh MapePave Mortar. It can also be used as a bonding slurry to bond Mapepave Mortar to solid concrete bases.

MapePave Mortar - a pre-blended, ready to use bedding mortar, with normal setting and controlled shrinkage for fast-drying bedding of pavers and tiles. It is applied at a thickness of between 10 - 100mm, dependant on substate build-up.

MapePave Brush in Grout - a ready-to-use polybutadiene-based drainage mortar for grouting pavers with joints of at least 5mm in width. Forming a strong bond and hardening quickly, MapePave Brush in Grout joints are particularly resistant to jet washing and de-icing salts. They also allow fast penetration of rainwater and resist freeze/thaw cycles, as well as the formation of moss and weeds. Joints can receive light foot traffic after 24 hours and are fully-hardened after 7 days.



For more information, please contact: info@mapei.co.uk or visit www.mapei.co.uk



TRENDS IN BUILDING & ARCHITECTURE: BUILT TO LAST

Fashions and fads come and go, but buildings and architecture leave a legacy. Architecture both reflects and shapes the society it serves. As a discipline, it provides a functional framework for fashionable structures that convey contemporary building trends and materials. As an art, architecture speaks to the prevailing preferences, problems and cultural norms and values of society at the time.

Nowadays, the most pressing problem of today's society - the need to address climate change and protect the natural environment

- has become the dominant factor driving decisions in the art and science of modern architecture and building.

This mega-trend is dictating choices in structural design, material manufacturing and building performance through 2024 and beyond.

Eva-Last, leaders in advanced composite building materials, unpacks how this legacy will impact current building trends and architecture:

Green Building & Sustainability as a Mega-Trend

Without a doubt, green building and sustainability is the dominant force influencing international urban development.

Green building is now the most prevalent movement happening in the built environment. The entire construction industry is looking to service an increasingly urbanised population, while reducing its enormous environmental impact. And never has the call for sustainable development been more urgent!

Statistics show that the construction sector contributes a whopping 7-8% towards global carbon emissions. And as government policies and building regulations force compliance to achieve ambitious carbon reduction targets, every segment of the construction sector - from materials manufacturers, design professionals to developers, property owners and project managers - are seeking ways to enhance their built environment without harming the natural one.

Progressive architects, designers and builders are favouring more sustainable green building designs over previously popular styles or traditional building materials.

Savvy building materials manufacturers, such as Eva-Last, are engineering new resource-efficient, eco-friendly and enhanced building components that can contribute towards a net zero carbon site, while energy-efficiency ratings and certifications such as LEED (Leadership in Energy and Environmental Design) are set to become the norm.

Energy-efficiency

The need to reduce our reliance on fossil fuels to power our everyday activities (and reduce pollution that causes climate change) has seen an emphasis on energy-efficiency and passive design principles across structures, and our appliances.

This encompasses everything that affects the energy required for lighting, heating and cooling, ventilation and indoor air quality.

Careful consideration of the aspect or orientation of the building on site and its natural environment improves its performance parameters around energy-efficiency, facilitating heating and cooling using natural light and airflow. This in turn, reduces the need for insulation, ventilation, shading or added lighting.

In addition, the use of materials with natural thermal regulation properties such as bamboo which outperforms concrete, or steel, further improves the energy-efficiency of the build. Materials like Eva-Last's VistaClad cladding profiles provide both an insulation barrier but also allow for building ventilation through design, simply by cladding the building's façade, while decorative shading or protection from glaring sunlight can be achieved using Lifespan's

lightweight architectural beams for pergolas or screening to further enhance energy-efficiency.

Eco-friendly materials

Responsibly sourced renewable and eco-friendly building materials are being specified with their carbon footprint in mind.

Everything from solar systems to rainwater harvesting, low-flow taps and drought-resistant landscaping, energy-efficient lighting to technically advanced products that conserve scarce natural resources are finding their way into modern buildings.

Resource-efficient, easily replenishable raw material inputs are replacing limited natural resources like wood with advanced composite products.



DECKING

Eva-Last's beautiful bamboo composites combine fast-growing bamboo with recycled plastic. Their range of composite decking, cladding, balusters and beams look like timber without contributing to deforestation. In addition, their recycled plastic content introduces superior wear characteristics and durability while simultaneously eliminating the mountains of plastic waste polluting our oceans and landfills.



Biophilic Design

This integrates nature into architecture to enhance wellbeing and sustainability. By incorporating natural elements such as greenery and natural light, biophilic design fosters a sense of calm and connection to the environment that improves productivity and health. It's evident in our preference for natural tones, textures and organic materials such as wood or stone, as well as our penchant for patterns of plantscapes and flora and the inclusion of landscaping and water features in our surroundings.

Eva-Last's latest composite decking range Pioneer connects people to plants by recreating the natural tones and textures of endangered wood species using photorealistic digital print technology. The embossed, patterned surface texture provides the most natural-looking finish in composite products yet.



Lightweight materials

Buildings are going up and getting taller due to limited space. This has spurred demand for new strong, durable but lightweight materials other than steel or concrete.

Eva-Last consistently introduces enhanced performance properties into their building products - the hollow aluminium core of Lifespan's lightweight architectural beams, or the glass-fibre reinforced (GFR) core of Pioneer and Apex Plus decking, allowing for increased spans, are examples of ingenious innovations specifically developed for these types of applications.

Remodel or Renew

High interest rates, labour costs and excessive material requirements, coupled with limited space and urban decay is driving the need to remodel or renew rather than build from scratch. Existing buildings such as abandoned factories, vacant offices or old outdoor structures are being given a facelift with attractive cladding, outdoor decks and patios and shady pergolas or rooftop lounges. These existing spaces are being repurposed into stylish accessory-dwelling units (ADU's) suitable for guesthouses, multi-generational living (such as garden flats) or extended living areas.

Conclusion

Since architecture and building leave a legacy for future generations, be sure to select a product that is built to last.

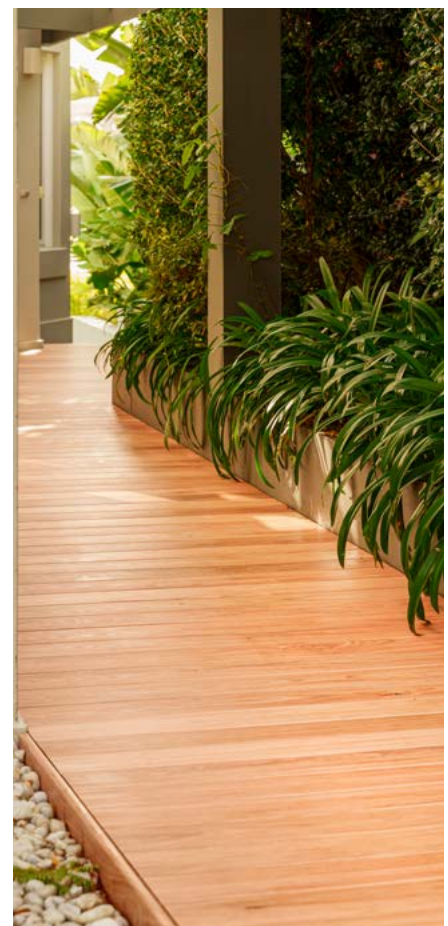

Eva-Last's extensive range of bamboo composite products are specifically designed to enhance the environment while minimising any negative impacts. Engineered to outperform traditional building materials, the collection boasts attractive low maintenance benefits combined with sterling sustainability credentials.

www.eva-last.co.uk

EVA-LAST®

INSPIRED BY NATURE, DESIGNED FOR LIFE.



WHEN YOU CHOOSE EVA-LAST, YOU'RE CHOOSING THE BEST SOLUTION FOR BOTH YOU AND THE ENVIRONMENT.

Eva-Last decking products are the low-maintenance, reliable alternative to timber. They are also free of toxic chemicals and preservatives normally used for the treatment of wooden decking. The beauty of wood, without the constant upkeep. An investment that saves time and money, and adds value to any outdoor project.

EVA-LAST®
INSPIRED BY NATURE, DESIGNED FOR LIFE.



LOW ENVIRONMENTAL IMPACT

Holistically sustainable manufacturing & use of raw materials



www.eva-last.co.uk

Scan for more info on our product range



Sourcing for your next decking project?

Look for the Mark



Find third-party verified and fit-for-purpose products and installers

From deck components and design engineers to wood coating solutions and specialised fixings.



Gripsure Accoya



London Decking Company



WJ Group Deckwright

DeckMark schemes require a full business audit and assessment followed by annual surveillance audits by TDCA.

The Timber Decking & Cladding Association is an independent, not-for-profit technical and advisory trade body. Recognised as the authoritative source of expert opinion in the UK.

Get in touch and find a supplier today

info@tdca.org.uk | 01977 558147

www.tdca.org.uk

BELOW THE SURFACE - IS YOUR DECKING SAFE?

One of the services the Timber Decking and Cladding Association (TDCA) offers, is to inspect and report on projects that have not lived up to the client's expectations. The organisation has seen some sights in its time but none so bad as this recent raised deck at a mobile home park.



Some support posts appeared to be floating - unconnected to the uneven ground, there was a haphazard mix of timber joist off-cuts and non-durable plywood was being used as packing material.

A deck should be constructed so that it is structurally sound and free draining. The statutory rules for constructing decks on permanent buildings is covered in UK planning and building regulations. Planning consent is required for decks more than 300mm from the ground and where planning consent is required, so too is compliance with Building Regulations. Technical plans and methods of construction must be submitted and approved by Building Control officers - to ensure the construction will be safe during its service life.

Although decks that are added onto holiday caravans and lodges are generally exempt from compliance because they are deemed as 'moveable structures', we believe this is not a licence to ignore established good building practice - quite the contrary.

Use an accredited installer

Whether you are adding a deck to your mobile home, adjoined to your permanent residence or free-standing in your garden, you should ensure it is safe and constructed properly. Thankfully the problem deck in these photos was replaced on TDCA's recommendation.

Our accredited installers are audited annually by TDCA to ensure best practice workmanship. Look for the DeckMark or CladMark badge when sourcing your next contractor. Equally, these schemes also cover products - from timber components to fixings, coatings and accessories.

Find your next supplier at our website: www.tdca.org.uk

TDCA Approved Installers



The London Decking Company

DECKBUILDERS
DESIGNED TO REFLECT A LIFESTYLE

Composite decking
has evolved...

Introducing

Evolution

Ecodek's new capped decking features EcoTech™, a protective outer layer for enhanced stain and fade resistance. Get a beautiful woodgrain texture and long-lasting performance.



scan to
find out more



SUSTAINABLE
OUTDOOR LIVING



UK manufactured



Low maintenance



Bespoke lengths



Fade and stain
resistant



Made from 90%
recycled and
sustainably sourced
materials



ecodek

For more details visit ecodek.co.uk,
call 01978 667840 or email enquiries@ecodek.co.uk

REVOLUTIONISE YOUR OUTDOOR PROJECTS WITH EXADECK: THE ULTIMATE DECKING SOLUTION



In the world of architectural design, finding durable, aesthetically pleasing, and high-performance materials is crucial. At Firedeck, we understand these needs and proudly introduce EXADECK, a groundbreaking decking system designed to meet the highest standards of quality and functionality.

EXADECK is not just another decking option; it's a revolutionary system of extruded porcelain decking boards, setting a new benchmark in the industry. Whether you're designing urban landscapes, public walkways, or private gardens, EXADECK offers unparalleled benefits that make it the ideal choice for any outdoor project.

One of the standout features of EXADECK is its exceptional fire resistance. Boasting an A1 fire rating, EXADECK provides the highest level of safety and reliability. It ensures peace of mind, particularly in areas prone to high temperatures and naked flames, making it an ideal choice for residential and commercial projects.

EXADECK's benefits extend far beyond fire resistance. Unlike traditional decking materials such as wood, EXADECK is weatherproof and impervious to moisture. This makes it perfect for environments where exposure to dampness, wind and salt are a concern, ensuring longevity and maintaining its

pristine condition over time. Its high mechanical resistance and remarkable breaking strength ensure that it can handle high pedestrian traffic with ease, making it suitable for high-traffic communal spaces. The overall durability of EXADECK is exceptional, with its inherently scratch-proof surface due to the porcelain extrusion process.

The system's resistance to extreme temperatures, including frost and ice, is another key advantage. EXADECK's zero water absorption prevents expansion and contraction due to temperature fluctuations, ensuring it remains functional even in the harshest winter conditions. The absorption resistance means that the boards are also stain-proof.

The ease of installation and low upkeep make EXADECK a cost-effective solution in the long run, allowing architects and designers to focus on creativity without worrying about durability issues. There is a 30-year warranty on the boards guaranteeing peace of mind.

For architects seeking a superior decking solution, EXADECK from Firedeck is the ultimate choice. Transform your outdoor spaces with a product that combines cutting-edge technology, robust performance, and timeless beauty.

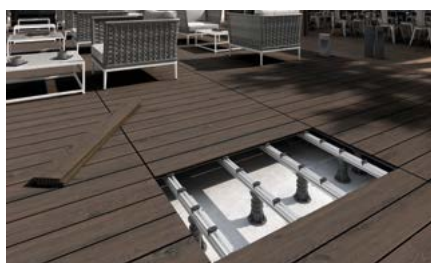
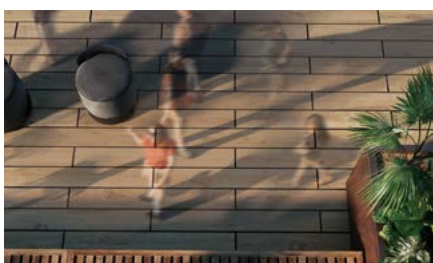

Discover more at www.firedeck.uk
and see how EXADECK can
revolutionise your outdoor projects.

+44 1264 311 113
sales@firedeck.uk

CREATE A GARDEN OASIS

with Exadeck porcelain decking

Anti-slip

Durable

Weatherproof

Low maintenance

Sustainable & Eco-friendly

Scratch and Stain Proof



Care about the environment? So do we. Exadeck is 100% recyclable, with up to 41% recycled content, winning the Archiproducts Sustainability award in 2022.

F FIRE DECK

CALL NOW
01264 311 113
sales@firedeck.uk



Anchor House
Courtesy: David Loy - Your Garden Design.

BRINGING YOUR GARDEN DESIGNS TO LIFE



Find out more about this project profile and **order free samples** at millboard.com

millboard
Live. Life. Outside.



PERFECT FOR WORKING FROM HOME



PROTECTING YOUR PRIVACY WITH STYLE



CREATE THE IDEAL DINING SPACE

MAKE YOUR GARDEN GREAT AGAIN

100% PREMIUM QUALITY	FREE SAMPLE SERVICE	VALUE PRICE MATCH	BUY ONLINE TODAY
--------------------------------	-------------------------------	-----------------------------	----------------------------

COCKLESTORM

0161 724 9595
WWW.COCKLESTORM.COM



ADJUSTABLE PEDESTALS FOR ALL TYPES OF TERRACES

www.buzon-world.com



Fully independently tested and approved by the Health & Safety Laboratory in Buxton, in accordance with British Standard BS 7976: 200

Anti-slip deck boards that stay slip hazard free

Low maintenance and long lasting
Perfect for all seasons

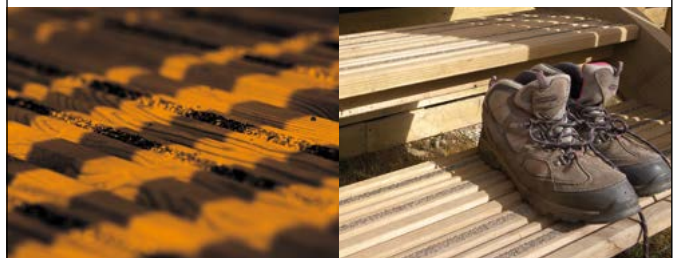

We can apply our DeckWright solution to your own timber deck products.

Interested in having anti-slip deck boards applied for your home?

Once applied, we'll return to you to sell. Please enquire for pricing.

Get in touch and we'll point you in the direction of your nearest stockist.

For more information call or email:
01482 338 950 | info@deckwright.co.uk

wj-group.co.uk



Up to
25 year
warranty

Introducing Endura:

Your Ultimate Decking & Cladding Solution

Crafted from natural timber and 100% recyclable, enjoy peace of mind with up to 25 year warranty. Splinter-free, slip-resistant, and incredibly durable, it's the perfect choice for both domestic commercial projects.

Explore the range today!

TREKKER
LUXURY DECKING & CLADDING

T. +44(0)1483 310800

www.trekkerglobal.com

4 EXPERT TIPS FOR BUILDING A WATER-RESISTANT DECK



It is common knowledge among professional builders that water is the enemy of timber and the leading cause of deterioration for decks. It can lead to mould, mildew, rot and premature deck failure. To prevent moisture from undermining your next installation, keep these four tips in mind:

1. Survey the slope

Water must drain away from a deck structure. Set the deck framing at a pitch of 1% to 2% to slope away from the building site. If you plan to install an under-deck drainage system, decide where the water will discharge. Consider adding a French drain (a.k.a. an engineered trench), reservoir or other means to redirect the water or collect it for use in watering a garden or planting area.

2. Protect the substructure

The lumber used in deck building is pressure-treated to be water-resistant - not waterproof. To protect a deck's structural elements from moisture and rot, it's critical to apply flashing tape, such as Trex® Protect, over all the joinery and blocking. Designed specifically for decking applications, and available in sizes for use on joists, bearers and rims, these self-adhesive butyl tapes

also seal deck fasteners and help screws to hold longer and stronger by preventing moisture penetration and defending against splitting that can result from seasonal freezing and thawing.

3. Use low-maintenance decking

Timber decks can be beautiful but any timber, whether pressure-treated lumber, cedar or exotic hardwood, must be cleaned regularly and coated every few years to keep it looking good and prevent water damage. That's why composite and PVC boards, which are practically impervious to water, continue to gain popularity. They require little upkeep and last for decades.

4. Divert water with a deck drainage system

For more comprehensive waterproofing of your substructure, consider adding a deck drainage system. Designed for use on elevated decks, these systems capture and divert water away from a deck. This not only protects the foundation from moisture penetration but also keeps the space beneath the deck dry and usable for storage or as an additional outdoor living area. Offering maximum protection, the

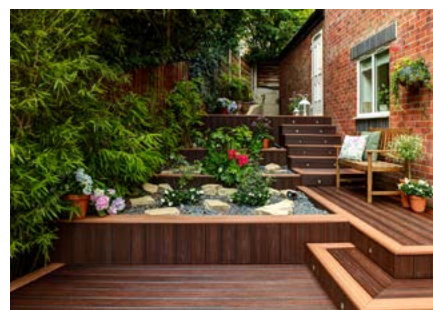

Trex® RainEscape® system installs above the joists of a deck to shield the entire foundation. It also allows homeowners to discreetly run gas and electrical lines beneath the drainage system and a soffit ceiling to power lights, ceiling fans, appliances and electronic components.

For more waterproofing tips, visit [TrexProtect.com](https://www.trexprotect.com).



Modern environments
require modern solutions.

THE
LUXURY DECKING
COMPANY

www.luxurydecking.co.uk sales@luxurydecking.co.uk 0330 236 9989

Scan the QR code to order your FREE sample box



- Double sided composite boards
- 25 Year Warranty
- 90% Recycled materials
- 6 stunning colour options



REESINK EXPANDS IRRIGATION RANGE WITH PERROT SPRINKLERS

MORE BEST-IN-CLASS IRRIGATION SOLUTIONS FOR SPORTS CUSTOMERS

By taking on the distribution of Perrot sprinklers in the UK, Reesink Hydro-Scapes is expanding its offering of professional irrigation solutions for sports customers.

Perrot is known for being able to provide the right irrigation solution to suit any size and meet any requirements, whether for natural, synthetic or hybrid turf. The various combinations of sprinklers available mean that an extremely wide range of different needs can be easily met.

Reesink is bringing to the UK three types of sprinkler technology in six powerful Perrot sprinklers to suit all sorts of sports surfaces - football, golf, hockey, tennis, even horse racetracks. Regardless of which sprinklers are chosen, Perrot systems can reach every inch, in every tight corner, ensuring maximum turf health with minimum water consumption says the manufacturer.

When Toro acquired the manufacturer of Perrot's retractable sprinklers, it was to grow Toro's presence in the sports field industry and provide more choice to customers and Reesink Hydro-Scapes was given the opportunity to take on the UK distribution of Perrot alongside Toro irrigation.

It was an easy decision to make, says Robert Jackson, Reesink Hydro-Scapes division manager: "Toro and Perrot come from the same place in terms of the commitment they have to manufacturing high-quality, professional irrigation products and providing exceptional service



to customers. This is of course something we have had in common with Toro for 40 years and having those values align with a new manufacturer was important.

"We take great pride in being able to provide our customers with extensive irrigation options and Perrot only adds to our range of best-in-class irrigation solutions. They are powerful sprinklers with great range and accuracy, and are well made, with high quality brass inserts which don't corrode."

In addition to those selling points, there's also the fact that they boast a casting range of up to 54m and their systems are expandable and flexible. Nothing, however, is quite as flexible as the Rollcar, which has no fixed installation and can be rolled to

apply water economically and cost-effectively wherever it is needed.

When it comes to synthetic turf, the VP3 provides uniform irrigation from the perimeter, cools down the surface and improves playability and speed, so whatever association mandates are in place, Perrot will cover them.

And there's no need to worry about the water quality, Perrot can irrigate with almost any water quality, whether it be rainwater or greywater.

To understand more about the new range and how it can benefit your venue and surface, visit reesink-hydrosapes.co.uk

Works with
Fountain Glo™
lights

Effective water solutions
for all landscapes

PICTURE PERFECT

**Fixed Fountains. For when aesthetics
are everything.**



Provides tranquillity and beauty for your lakes and ponds. Made from corrosion-resistant and durable marine-grade stainless steel, the stand chamber fits flush with the surface to create that picture perfect landscape. And with a power control centre cable with quick disconnect, installation and maintenance is easy, too.

reesink-hydroscares.co.uk

ADVANCED KFS SPECIAL VEHICLES LOAD & GO®: THE ULTIMATE GROUNDS MAINTENANCE VEHICLE



AKFS is a recognised market leader in commercial vehicle design and construction, firmly holding the top spot within the commercial vehicle industry - our reputation for excellence is well-deserved, reflecting our commitment to quality, innovation and our Built Without Compromise ethos.

For many years, one vehicle design from our portfolio of commercial vehicle solutions has stood out as a clear favourite among our grounds maintenance, landscaping, and lawn maintenance customers: the AKFS Load & Go® Utility Vehicle.

Its superior design and reliability have made it the go-to choice in the industry. Engineered specifically for the grounds maintenance and lawn management sectors, and incorporating valuable feedback from industry giant idverde, the Load & Go® delivers exceptional ROI, usability, and dependability.

At its core, the AKFS Load & Go® vehicle design simplifies the transportation of ride-on lawn mowers, associated grounds maintenance equipment, and tools, ensuring they are moved securely and safely.

Each Load & Go® vehicle comes as standard with a beavertail bed, slip-resistant flooring to the assisted tailgate, multiple lashing points, and fall arrest straps. With a total conversion weight of approximately 320kg, including the assisted tailgate, businesses benefit from the best possible payload options across all base vehicle platforms.

For companies looking to create a fully bespoke vehicle to meet their specific needs, the Load & Go® offers a wide range of optional extras and design choices. Options include various bed lengths (depending on the base vehicle's wheelbase), secure storage lockers, LED strobes to both the front and rear of the vehicle, winch systems, tow bars, LED light bars, and rear parking sensors. This flexibility ensures that each Load & Go® can be tailored precisely to the requirements of any business.

AKFS is proud to be a Renault Approved Converter, with many of our Load & Go® vehicles built upon their 3500kg GVW Renault Master chassis cab. However, they can also be constructed on chassis' from other leading manufacturers, including Mercedes, Nissan, Fiat, Ford, Isuzu, and Volkswagen, among others.

For more information, contact our Grounds Maintenance Product Specialists on 01246 250022.

This is a unique opportunity to discover how AKFS's tailored vehicle conversions can streamline your business operations, setting a new standard in the industry for efficiency and safety.



www.advanced-kfs.co.uk

AKFS Ltd

Load & Go®
Utility Vehicle



Quote LAUD68 to our Product Specialists and receive a free "Cab Comfort Pack" on all orders processed before C.o.B 30/09/2024



01246 250022

www.advanced-kfs.co.uk



STRATEGIC PARTNER
AL-KO
QUALITY FOR LIFE

Built Without Compromise

CELEBRATE EXCELLENCE AT THE NATIONAL LANDSCAPE AWARDS – TICKETS ON SALE MID-AUGUST!



Get ready to immerse yourself in a day filled with inspiration, and celebration as the most prestigious event in the landscaping industry returns this year - the National Landscape Awards on the 6 December 2024! Tickets for this illustrious occasion will go on sale in mid-August, and you won't want to miss securing your spot at the forefront of landscape excellence.

Why Attend the National Landscape Awards?

1. Recognise Excellence in Landscaping:

The National Landscape Awards honour the outstanding achievements of professionals in the landscaping industry. From innovative designs to sustainable practices, this event showcases the pinnacle of talent and creativity. Attendees will have the opportunity to witness first-hand the projects that set new standards and inspire future trends.

2. Network with Industry Leaders:

This event is a melting pot of the industry's best and brightest. It's a unique opportunity to connect with fellow professionals, share ideas, and build lasting relationships. Whether you're a seasoned veteran or new to the field, the National Landscape Awards provide a platform to exchange knowledge and foster collaborations that could propel your career to new heights.

3. Gain Insight and Inspiration:

Be prepared to be inspired by the breathtaking projects and the stories behind them. The awards ceremony not only highlights the technical excellence but also the passion and dedication that drive the industry forward.

4. Celebrate in Style: Held at the prestigious J W Marriott, Grosvenor House, Park Lane, the National Landscape Awards promise an afternoon of celebration. Enjoy a

3-course lunch, and the company of your peers as you celebrate the achievements of the landscape community. It's an opportunity to dress up, have fun, and honour the hard work that goes into creating beautiful and functional outdoor spaces.

5. Be Part of an Exclusive Event:

Tickets for the National Landscape Awards are highly sought after and limited. By attending, you're joining an exclusive group of professionals who are committed to excellence in landscaping. Don't miss your chance to be part of this distinguished event and to celebrate with the best in the business.

Save the 6 December 2024 in your diary get ready to purchase your tickets in mid-August. Stay tuned for further announcements and details on how to secure your place at the National Landscape Awards.

Join us for an unforgettable day celebrating the art, innovation, and excellence in landscaping. See you there!

Visit baliawards.co.uk or follow the British Association of Landscape Industries on our social channels for the latest updates!



BALI
National
Landscape
Awards



Headline Sponsor

OPEN FOR ENTRIES

Supplier Exceptional Service/Employer Excellence Categories

Final Deadline: 5 July 2024

International

Final Deadline: 5 July 2024

The National Landscape Awards Ceremony will be held on Friday 6 December 2024, JW Marriott Grosvenor House, Park Lane, London

 @BALI_Landscape

 balilandscapeuk

Visit baliawards.co.uk for entry criteria and to start your entry

For general enquiries, contact **Emily Feeney**
Telephone: **07936 944258**
Email: emily.feeney@bali.org.uk

For sponsorship opportunities, contact **Joanna Pieprzak**
Telephone: **07842 436597**
Email: joanna.pieprzak@bali.org.uk

HEADLINE SPONSOR



SPONSORED BY

adtrak.

BOURNE
AMENITY

TOPSOIL Responsible sourced,
certified soils -
The experts that care

CQ Business
Management Software

Crowders Growing since 1798

easiglass™

EURO PLANTS
UK LIMITED

Green-tree
Topsail

GreenBlue
URBAN Creating beautiful urban spaces and landscapes

Ground
Control

Miller

JOHNSONS
LANDSCAPE

Makita

M-M
Sells | Aggregates | Waste

millboard
Live. Life. Outside.

REESINK
Turfcare

Rochfords
Partners for the landscape industry

VAN DEN BERK
UK LIMITED

WRIGHT
LANDSCAPES



GREEN-TECH SUPPLY MATERIALS FOR TREE PLANTING AROUND A NEW WIMPEY TAYLOR SUDS SCHEME

Set in the vibrant town of Ipswich, Wolsey Grange is a growing community of newly built homes by Taylor Wimpey

As part of the Construction Environmental Management Plan, a sustainable surface water drainage system (SuDS) was implemented, designed to reduce

rates of stormwater run-off. An Attenuation basin will control water flow from the site into the existing watercourse. These sustainable drainage features will also create a range of water habitats for wildlife. A maintenance regime has been established to ensure the future performance of sustainable drainage features.

Attenuation basins are a common sight on most new build sites and allow for safe and contained storage for excess rain and stormwater as it allows for its release over time into the sewer system at a controlled rate. They remove much of the potential flooding risk caused by the inability of excess water to drain safely.



Cox Landscapes is the experienced landscape contractor on this large-scale project and has vast experience in the landscaping of attenuation basins. They were responsible for the planting area outside of the attenuation basin which involved planting potted plants and bare root trees and protecting these by staking and installing Tubex tree shelters.

Green-tech is Cox Landscapes supplier for landscaping materials and supplied circa 500 stakes and

Holdfast natural tree hessian ties for securing the stakes to the trees, as well as 60cm Tubex tree shelters. In Keeping with this biodiverse and sustainable project the Natural tree ties are made entirely of natural fibres and are fully biodegradable. Unlike other tree ties, a spacer is not required when using with Natural tree tie. You can form a spacer by using the tie itself.

15 rolls of Ecomatt weed control fabric were supplied and installed before being planted

and finished off with decorative bark. The Ecomatt offers a great biodegradable tree weed control option that degrades over two growing seasons. It is manufactured in the UK, exclusively for Green-tech Ltd from 100% recycled materials: and is needle punched onto a film backing, to allow both air and water to pass through the layers.

www.green-tech.co.uk

FROM BIOSWALES TO BIODIVERSITY: PICTORIAL MEADOWS TWO DECADES OF NATURE-BASED SOLUTIONS



Rotherham's eight-mile 'River of Flowers' verge project, delivered by Pictorial Meadows

With urban nature-based solutions now integral to policymaking in the UK and worldwide, the demand for companies capable of designing and implementing these solutions is greater than ever. From sustainable drainage projects like bioswales to, managing roadside verges to cut costs, boost Biodiversity Net Gain, enhancing urban spaces for the benefit of people and nature has become a critical priority.

At Pictorial Meadows, we have always been in the business of developing and delivering urban nature-based solutions. Throughout a twenty-year collaboration with the University of Sheffield's Department of Landscape Architecture, we have been developing the technical understanding required to deliver urban nature-based solutions alongside a range of products and services to support their widespread implementation.

Flowering Meadows and Local Regeneration. The Pictorial Meadows company was first incorporated to create high-impact meadow seed mixes to benefit both people and pollinators and was used extensively

on large areas of cleared housing land in Sheffield. These spectacular, colourful, Pictorial Meadows transformed areas associated with dereliction and abandonment from brown fields to flower fields, changing the way that residents felt about their environment and supporting a narrative shift in what had been some of the most deprived areas in Sheffield. Today, our range of seed and wildflower turf mixes are used by landowners looking for ways to enhance their urban green spaces such as roadsides, parks, housing areas and visitor attractions.

Managing Urban Grasslands for People and Nature. Around two-thirds of green infrastructure in the UK is mown amenity grass, which often provides relatively little benefit to people or nature. By developing alternative meadow management approaches for these areas, we can deliver a wide range of well-researched benefits, including increased plant and animal diversity, a potential reduction in costs and carbon emissions from mowing and proven wellbeing benefits for people. For the last ten years, our team of Landscape Managers have offered a meadows consultancy service helping landowners and managers develop strategies and specifications to create and maintain beautiful and biodiverse meadows



Bioswale part of SuDS for Severn Trent Water in Mansfield

in parks, gardens, urban green spaces and new developments.

A Complete Solution for SuDS.

Pictorial Meadows developed and supplied the specialist substrates and plants used in the Grey to Green project in Sheffield - probably the UK's most prominent and celebrated SuDS scheme. These substrates are engineered to govern water infiltration and retention to meet civil engineering specifications, whilst providing the perfect conditions for a wide range of ornamental plants. Pictorial Meadows are now working on SuDS for Severn Trent Water across Mansfield, supplying rain garden substrate, plants, meadow turf, installation and maintenance as an integrated solution.

Green Roofs: Biodiversity in (and on) the Built Environment.

As part of SuDS, green roofs have been a widely adopted nature-based solution for many years with their ability to slow and reduce the volume of water entering drains, create attractive and biodiverse habitats, insulate and cool buildings. Pictorial Meadows have been developing, producing and supplying green roof products and services such as project consultancy and our industry-leading 'Botanical Skyline' meadow turf to green roofs for over twenty years.

As part of The Green Estate Community Interest Company, Pictorial Meadows have been creating adaptive and resilient green urban spaces for over twenty years. Our mission has always been to create more sustainable, resilient and liveable cities by integrating nature into urban planning and design.

Pictorial Meadows

Transform urban sites with Pictorial Meadows

Beautiful and robust plants that deliver maximum impact for minimum input

Botanical Skyline – for all green roofs



Patchwork Quilt – resilient & adaptable



Super Pollinator – long flowering



Classic – waves of colour



Stunning Visual Impact

100% flowers, extended & continuous successional flowering

Enhances Flood Resilience

Proven in Sustainable Urban Drainage Systems (SuDS)

Premium Green Roof Solutions

Species rich, colonises with minimum fuss & maximum impact

Peat & Plastic-Free Turf

100% peat-free product with no plastic netting



the
green
estate

COMMUNITY
INTEREST
COMPANY

pictorialmeadows.co.uk
0114 267 7635

TRANSFORMING LANDSCAPING WITH BIOCHAR: THE ECO-FRIENDLY TREE SOIL ENHANCER



In today's drive towards sustainability and ecological stewardship, biochar is emerging as a key component, particularly when utilised as a tree soil improver. It's becoming essential for enhancing both new plantings and the revitalisation of older and veteran trees.

The Magic of Enriched Biochar Explained

Biochar is a form of charcoal, produced through the process of pyrolysis - the thermal decomposition of organic material in the absence of oxygen. Its application in landscaping is transformative, enhancing soil properties, increasing water retention, and providing a refuge for beneficial microorganisms. In the quest for greener landscapes, the superiority of enriched biochar over its plain counterpart marks a significant advancement. Enriched biochar, such as that offered by Carbon Gold, goes beyond the basic

benefits of traditional biochar by incorporating a blend of natural biology and fungi. This not only addresses the inherent issue of nutrient leaching associated with plain biochar, but also fosters a more conducive environment for plant and tree growth.

The addition of beneficial microbes and mycorrhizal fungi into the biochar matrix creates a symbiotic relationship with the plant roots, enhancing nutrient uptake, improving soil structure, and increasing water retention. These enriched properties ensure that trees and woody plants are not just surviving but thriving, by getting off to the best possible start with a robust foundation for long-term health and growth.

Pioneering Urban Greenery with Carbon Gold

For new plantings, the integration of biochar-based soil improvers can significantly accelerate growth by improving root development and nutrient uptake. This is especially crucial in urban environments where soil quality often lacks the richness found in undisturbed natural landscapes.

By incorporating Carbon Gold's enriched biochar into the soil, landscape architects and urban planners can ensure a more resilient and vibrant green infrastructure.

Revitalising Veteran Trees with Biochar Tree Soil Improver

Moreover, the rehabilitation of older and veteran trees presents a unique set of challenges, often involving compromised soil health. Here, biochar's role becomes even more

critical. Its ability to rejuvenate and restore soil fertility can breathe new life into ageing trees, enhancing their ability to withstand the stresses of urban environments and disease. Carbon Gold's Biochar Tree Soil Improver, with its added natural biology and fungi, offers a lifeline, promoting healthier, more resilient arboreal plants.

Sustainability: The Core of Biochar's Appeal

Sustainability is at the heart of biochar's appeal. Carbon Gold's products have been organically certified by the Soil Association since 2007 and are produced in an eco-friendly manner within the UK, emphasising local sourcing and minimising carbon footprint. This aligns with the broader goals of landscape and urban design to create sustainable, green spaces that contribute to the well-being of communities and the planet.

The use of enriched biochar in landscaping represents a significant step forward in sustainable urban development. Carbon Gold's innovative products exemplify the potential of combining traditional knowledge with modern science to address environmental challenges.

As we continue to reimagine our urban landscapes, Carbon Gold's suite of enriched biochar products stand out as key components in fostering healthy, resilient, and beautiful green spaces for future generations.

For further information email sales@carbongold.com or telephone 0117 2440032

CARBON GOLD[®]



DRAINAGE OR NO DRAINAGE - PUMP TECHNOLOGY LTD HAS A SOLUTION FOR INSTALLING A TOILET ANYWHERE!

Modern holiday lets such as shepherds' huts, pods and glamping sites always require toilets. If there is no gravity drainage to the public sewer Pump Technology Ltd offer many solutions. Here are just two of them!

When a water supply is available, but no gravity drainage, a small, below ground pumping station offers is the best option.

For this, the Saniflo 110, one of the most robust pumping stations on the market, is ideal. It comes complete with an automatic, submersible pump and alarm system.

The tank is constructed from a high density, rotational moulded polyethylene, giving excellent mechanical strength and resistance to possible chemical and UV attack.

If no drainage is available, then an incineration toilet can be used!

Cinderella toilets do not require a water or a sewage connection. Incineration transforms waste into odorless and hygienic, sterile ash which can be safely disposed of by tipping onto the garden.



Based in Aldermaston, Pump Technology Ltd, is the UK's leading wastewater and sewage pumping equipment stockiest.

For more information: 0118 9821 555
www.pumptechnology.co.uk
www.saniflo-pumps.co.uk
www.cinderellauk.co.uk

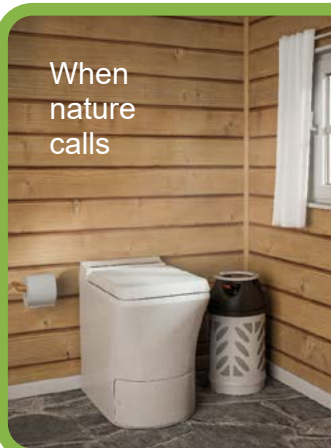

When nature calls



Cinderella[®]
Incineration Toilets

0118 9821 555

- Ideal for static sites such as: - Garden rooms, huts or 'glamping'.
- And mobile situations such as: - Canal and house boats, vehicles or mobile containers. LPG gas (Propane) or electric versions available.

www.cinderellauk.com



propel[®]

LANDSCAPING ASSET FINANCE CASE STUDY FEATURE

By Propel Finance

Propel equips leading Landscaping business to drive growth

Propel recently financed a cherry picker for a leading Landscaping business; supporting the customer to achieve their development ambitions. Following this purchase, Propel helped the customer secure twelve more deals towards a range of business critical assets.

Feedback from the customer:

"We were initially referred to Propel as we required asset finance towards a cherry picker. We were impressed by the whole process, while the speed rate of securing the finance was very quick and efficient. The Propel team were outstanding; and the whole experience of dealing with them was excellent. We had so much confidence in Propel. It was a no brainer for us to return to them for further finance. They've since managed to help us purchase several other key assets such as woodchippers, cars, trucks and vans."

Maintain your advantage

To discuss how you could benefit from an asset finance solution designed around your business, call Propel's specialist team on 01633 982922 or email contact@propelfinance.co.uk.

propel[®]

Cutting Edge Machinery and Vehicle Finance

for Groundskeeping & Landscaping Businesses

- Access the latest machinery and vehicles immediately
- No large upfront payment, preserving capital
- Boost your cash flow by spreading the costs over time
- Flexible finance solutions tailored to your seasonal cash flow requirements
- Fixed payments protect your business against inflation
- Fast decisions, so no delays to important new contracts

Propel is the fastest-growing asset finance company in the UK; and has a track record of over 25 years in supporting Groundskeeping businesses in achieving their growth ambitions.

Talk to Propel's asset finance experts today for fast and flexible equipment and vehicle finance solutions designed to power your growth.

Finance is subject to status. Terms and Conditions Apply. Propel acts as a lender or a credit broker for business customers only.

✉ contact@propelfinance.co.uk
 ☎ 01633 982 922
 🌐 www.propelfinance.co.uk

DCM MINIGRAN® FERTILISER

Natural Technology For Turf And Soil

MINIGRAN VITAL-GREEN 14-4-7



•Up to 100 days controlled release

Application Rate: 35 grams per square metre
Each 25 KG bag will treat 714 square metres
IMPORTANT: 14 bags will treat 1 hectare

Total Nitrogen 14%
3.0% Ammoniacal Nitrogen
6.0% Urea Nitrogen
5.0% Water Insoluble Nitrogen*

Available Phosphate (P₂O₅) 4.0% (1.7%P)
Soluble Potash (K₂O).....7.0% (5.8%K)
Magnesium (MgO)..... 3.0% (1.8%Mg)
Iron (Fe) 0.15%
0.15% Chelated Iron (Fe)

MINIGRAN SPORT-MIX 8-3-12



•Up to 100 days controlled release

Application Rate: 35 grams per square metre
Each 25 KG bag will treat 714 square metres
IMPORTANT: 14 bags will treat 1 hectare

Total Nitrogen 8.0%
1.0% Ammoniacal Nitrogen
3.0% Urea Nitrogen
4.0% Water Insoluble Nitrogen*

Available Phosphate (P₂O₅)..... 3.0% (1.3% P)
Soluble Potash (K₂O).....12.0% (9.9% K)
Magnesium (MgO).....3.0% (1.8% Mg)

MINIGRAN GREEN BALANCE 9-0-9



•Up to 100 days controlled release

Application Rate: 35 grams per square metre
Each 25 KG bag will treat 714 square metres
IMPORTANT: 14 bags will treat 1 hectare

Total Nitrogen 9.0%
3.0% Ammoniacal Nitrogen
3.0% Urea Nitrogen
3.0% Water Insoluble Nitrogen*

Soluble Potash (K₂O) 9.0% (7.5%K)
Magnesium (MgO)..... 2.0% (1.2%Mg)
Iron (Fe) 2.0%
2.0% Water Soluble Iron (Fe)

MIXTURE OF VEGETABLE, ANIMAL AND/OR MINERAL INGREDIENTS



EACH INGREDIENT HAS ITS SPECIFIC NPK CONTENT

EACH INGREDIENT IS A FEEDING SOURCE FOR SOIL LIFE





FLOOD CONTROL INTERNATIONAL: THE WATER STOPS HERE

As is becoming ever more apparent, global warming and the rapid expansion of cities are contributing to the frequency and severity of flooding. The challenge of managing flood risk is intensifying, posing severe threats to landscapes, infrastructures and homes. Here at Flood Control International, we are at the forefront of this critical issue, offering innovative solutions that redefine how cities, landscapes and individuals can prepare and respond to flooding.

Since 1994, Flood Control has designed, supplied and installed the widest range of flood protection solutions in the world. Our experience spans thousands of projects and together with the full spectrum of associated professional services, we pride ourselves on our ability to offer the most innovative and effective flood defences available today.

Available flood defense systems range from demountable flood barriers to automatic flood gates all designed by our talented in-house team of technical specialists and engineers that ensure each solution is tailored to meet the unique demands of every client.

All our flood solutions are engineered and manufactured to withstand the most extreme conditions while minimising disruption to everyday life. For instance, our demountable barriers can be quickly deployed and easily removed, making them ideal for both permanent and temporary flood responses. This flexibility is crucial in a world where climate change makes flood patterns increasingly unpredictable.

Our dedication to innovation and quality has earned us a global reputation. Our systems are installed worldwide, from the streets of

New York to riverside properties in Brisbane, protecting countless lives and properties from the devastating effects of floods.

As the threat from flooding continue to grow, Flood Control International remains committed to leading the way in providing innovative, effective and above all else, dependable, flood protection solutions, to ensure a safer future for communities around the world.

The Water Stops Here®



THE WATER STOPS HERE®



Since 1994, Flood Control has designed, supplied and installed the widest range of flood protection solutions in the world, across thousands of projects, together with the full spectrum of associated design services.

Our technical specialists and engineers produce both standard and custom designs for our range of **flood barriers**, **flood gates** and **flood doors**, to suit new build developments and existing buildings.





HEDGING PLANT SPECIALISTS

Hedges Direct is the UK's leading supplier of hedging plants, despatching direct from our 16 acre nursery site in Lancashire, covering all of mainland UK - and with nearly 20 years horticulture experience, we make buying hedges easy.

As a Hedging plant specialist, we have plants for every project - from popular evergreens to UK grown native varieties, all available in a range of heights and root types, with year round options in over 100 species.

Expert Advice

The Hedges Direct trade team are highly experienced and provide expert advice and a friendly, efficient and flexible service tailored to work for you. They're here to help you with all your planting requirements, whether we stock it or not. We work with growers and suppliers of all types of plants from across the UK

and Europe, meaning we can be your complete one-stop-shop for plants, saving you both time and money.

No quibble, 12 Month plant guarantee

We never compromise on quality. Our teams work hard to hand-pick your plants to ensure that you will get the best quality plants for your project. The Hedges Direct 12 month guarantee is our promise that you can buy our plants with complete confidence - if any fail within the first 12 months after delivery, we will replace them.

Delivered with care

We have been delivering plants since 2005, so we know our stuff. We offer trade customers a flexible delivery service so you can have your plants delivered on a date that works around you and your projects. We can deliver directly to you or to your customer, whatever suits best.

Who Are Our Trade Customers?

Hedges Direct is the hedging specialist of choice for many companies in the public and private sector. We regularly work with Landscapers and Garden Maintenance companies, Garden Designers and Landscape Architects as well as Property Developers, Builders, Leisure Companies, Farmers and Land Managers on all land and design projects.

From the public sector we work hand in hand with local councils and educational establishments to help improve the local environment, plus promote health and wellbeing.

Explore more at hedgesdirect.co.uk
or call our trade team on
01257 806101



Hedges Direct is the UK's leading supplier of hedging plants. We offer the largest range of hedging plants in the UK, from 10cm to 8m and over 100 hedging species.

Whether you are looking for decorative hedging, boundary hedges, screening and partitions - or perhaps need to create privacy, improve land drainage, or reduce noise and wind, we have hedging options and solutions to suit all situations and budgets.

Our dedicated trade team are here to help. They offer expert advice and bespoke trade pricing along with a completely flexible, fast and efficient delivery service, tailored to match you and your specific requirements.

We don't just stop at hedging either - with grower contacts from all over the UK and Europe, we can source all your planting requirements whether that's shrubs, trees, topiary or garden plants for a complete one-stop-shop service.

Contact us today to see how we can help you!



01257 806101

trade@hedgesdirect.co.uk

www.hedgesdirect.co.uk

 **HEDGES DIRECT**

INNOVATIVE WOODEN CLIMBING FRAMES



A non-prescriptive form of play, the Playspaces pole climbers are fast becoming one of their most popular product types. Their innovative combination of wooden climbing frames and ropes provide a stimulating setting for children to play. Resembling the popular children's game 'Pick Up Sticks', the pole climbers' scattered appearance and non-uniform design creates a challenging play environment for children, encouraging the development of core balance skills, coordination and overall body strength. Children are also inspired to use their imagination while climbing, hanging or balancing, as well as thinking strategically about traversing the climbing frame. With a wide variety of sizes, styles and options there is a suitable pole climber for every play space, from Early Years upwards.

The pole climbers are just one part of Playspaces' vast selection of outdoor playground equipment. Playspaces provide an end to end service, including design, manufacture, supply and install of their bespoke equipment, providing individual play equipment pieces or complete turnkey playground builds.

Their extensive range of timber playground equipment has products suitable for every age and setting, including safety and all-weather surfacing. Their imaginative designs and robust high-quality installations are suitable



for schools, nurseries, parks, housing developments and commercial outdoor play areas.

Playspaces strongly believe in the importance of outdoor play and sport for children's development and enjoyment, and they strive to supply the best equipment to facilitate physical play, learning and fun.

Playspaces' physical play equipment and play schemes comply with the most stringent safety standards and all their manufactured products come with full installation instructions, with each component part simple to identify.

From trim trails and towers to swings, slides and climbing frames, Playspaces will work with you from initial site visits and design discussions, through manufacturing to installation as well as taking care of your subsequent safety and maintenance inspections and repairs.

enquiries@playspaces.co.uk | Tel 01622 844 238
www.playspaces.co.uk



Ask us about
our extensive
Pole Climber
range!



**Bespoke Design, Physical Play Equipment,
Outdoor Learning, UK Manufactured**





Find us on:   
T: 01622 844 238
E: info@playspaces.co.uk

playspaces.co.uk



ECO RUBBER CHIPPINGS

Colour Variations



**Safe, long lasting, trouble free, colourful ground cover.
Ideal for play areas, landscaping & animal settings.**

01977 529 570 | info@ecohippings.co.uk

ecohippings.co.uk



Our football and rugby crowd and pitch barriers are flexible, safe, durable and strong.

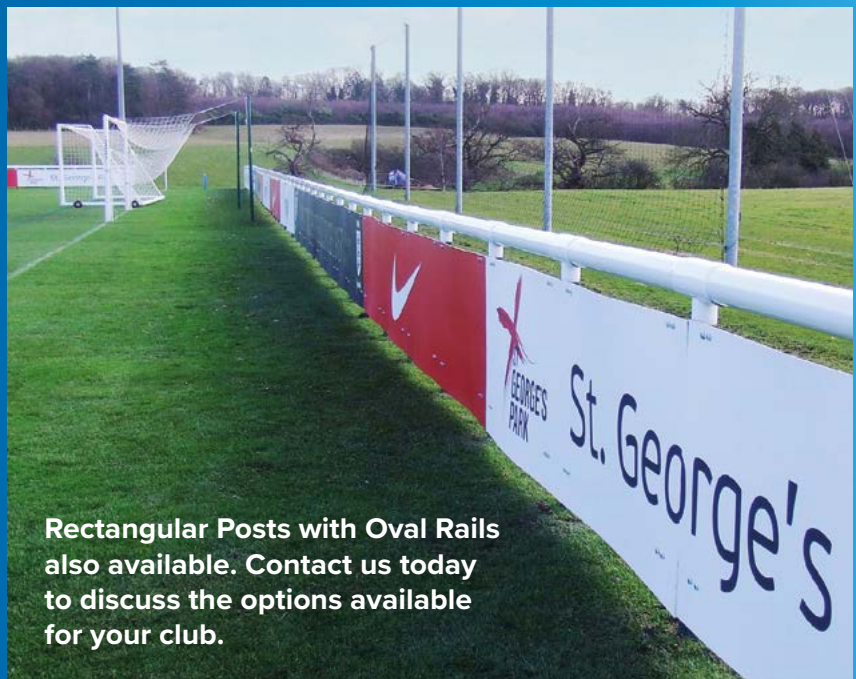

Rectangular Posts with Oval Rails also available. Contact us today to discuss the options available for your club.

www.barriersint.com

sales@barriersint.com

+44 (0)1 666 829 100



A SPRING CLEAN FOR YOUR PLAYING PITCH

In the same way the needs of your garden change through the seasons, so do the needs of your sports pitches. As Spring is now here it's time to start thinking about what needs to be done to maintain your pitches and ensure they are ready for the forthcoming summer period.

Getting off to the right start

Spring is the perfect time to start preparation of your pitch for the upcoming playing seasons. Focusing on cutting the grass and aeration of the pitch, to allow water, air and nutrients to penetrate down to the roots, will ensure you have laid the foundations for the coming year.

To gain a consistent surface throughout the pitch, we recommend overseeding and feeding it. These two activities allow you to plant grass seeds directly onto the lawn without turning it and provide the nutrients it needs to maintain and encourage healthy growth.

Late Spring Renovation

Towards the end of Spring, it is time for a few last renovations. Continuing to overseed and aerate the soil, along with removing thatch and debris from the surface, and performing topdressing by spreading a thin layer of material like sand over the grass you can be confident your pitch will stand up to the rigours of the games to be played on it.

Constant maintenance is key

Next up, it's important to maintain regular mowing to make sure the grass is kept at the optimal height for performance. While the optimal height may change depending upon the sport, for most pitches it is around 25-30mm, which ensures your players' movement isn't restricted. Make sure you also check the integrity of your irrigation and drainage arrangement to avoid water logging issues. It is also important to monitor for small pests on the pitch as well as other

potential natural problems like harmful fungi, to ensure the safety of your players.

A year-round investment

A good pitch requires commitment to well-planned, year-round maintenance. Here, at Kestrel Contracts, we develop long-term partnerships with our clients and we are passionate about helping our customers have the best playing surfaces available. We are more than happy to visit you and have a conversation about the specific needs of your playing surfaces.

To find out more about our services, get in touch.

www.kestrelcontractors.com
01256 880 488
info@kestrelcontractors.co.uk

LANDSCAPE & URBAN DESIGN



Providing the UK's major landscaping and urban design specifiers with a comprehensive look at the latest in landscape design and management, design innovations, garden design, the built and natural environment, public space, green space, open space and environmental sustainability.

FREE DIGITAL MAGAZINE SUBSCRIPTION

Subscription enquiries:

Call - 01304 806039
info@mhmagazine.co.uk

Advertising enquiries:

Lee Martin - 01227 936974
lee@landud.co.uk

Editorial submissions or enquiries:

Antony Holter - 01304 806039
antony@mhmagazine.co.uk



SUBSCRIBE TODAY!

#designthenation

clatterbridge hospital



01254 685 185

sales@woodscape.co.uk

woodscape.co.uk

woodscapegroup

woodscapectd

woodscape_street_furniture



Woodscape.

Bespoke Street Furniture