

Report No. NA-3057

~~CONFIDENTIAL~~

A1
(X) F-51J spec

Classified or Controlled
OR changed to
Auth: C. G. Ame
6 Dec 50
By Capt. A. G. Brown

PILOT'S HANDBOOK OF FLIGHT OPERATING INSTRUCTIONS
FOR THE
XP-51J AIRPLANE

Powered With Allison
V-1710-119 Engine

Manufactured by
North American Aviation, Inc.
Inglewood, California

February 20, 1945

~~CONFIDENTIAL~~

X 72092

TABLE OF CONTENTS

	Page
Section I DESCRIPTION	
1. General	1
2. Flight Controls	1
3. Landing Gear	1
4. Brakes	2
5. Hydraulic System	2
6. Power Plant	2
7. Fuel System	8
3. Oil System	3
9. Cooling Systems	3
10. Electrical System	17
Section II PILOT'S OPERATING INSTRUCTIONS	
1. Flight Restrictions	18
2. Before Entering Cockpit	18
3. On Entering Cockpit	13
4. Starting Engine	20
5. Engine Warm-up	23
6. Scramble Take-off	24
7. Engine and Accessories Ground Test	24
3. Taxiing Instructions	25
9. Before Take-off	26
10. Take-off	26
11. Engine Failure During Take-off	27
12. Climb	23
13. During Flight	23
14. Flight Operation	23
15. General Flying Characteristics	29
16. Engine Failure During Flight	29
17. Stalls	30
13. Acrobatics	30
19. Diving	30
20. Night Flying	30
21. Emergency Exit	31
22. Approach and Landing	32
23. Stopping Engine	33
24. Before Leaving Cockpit	34
Section III OPERATING DATA	35
Section IV COMMUNICATION EQUIPMENT	
1. General	36
2. Command Set, SCR-522-A	36
3. Identification Equipment	33
4. Pyrotechnic Signal Pistol	33

Classification Cancelled
OR Changed to
Auth: G G Amc
10 Dec 50
By Capt. A. G. Bryson

Section V ARMAMENT

1. Gunnery Equipment	40
2. Bombing Equipment	42

Section VI OXYGEN EQUIPMENT

1. Description	43
2. Operation	43

Section VII HEATING, VENTILATING, AND DEFROSTING SYSTEM

1. Description	46
2. Operation	46

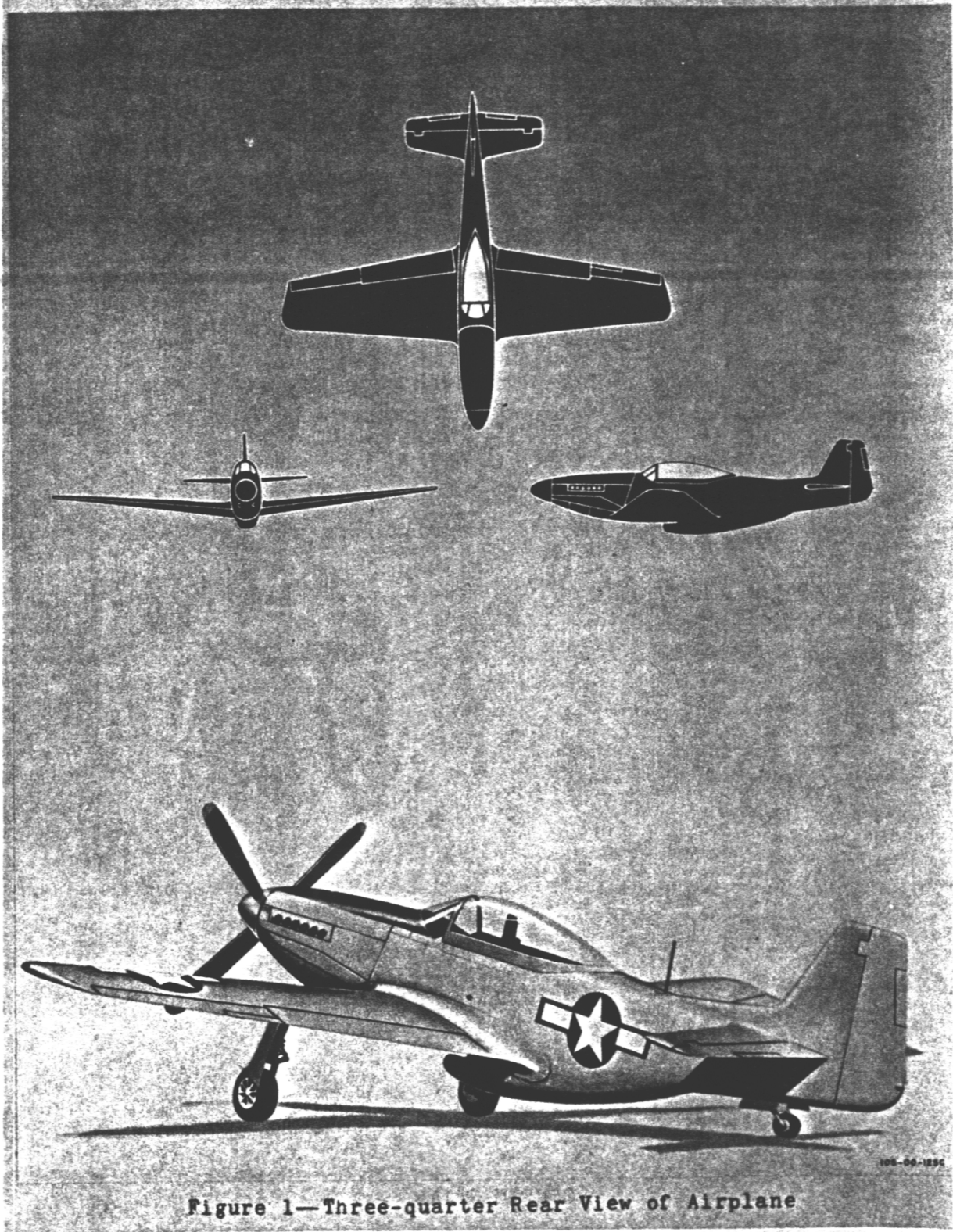

Figure 1—Three-quarter Rear View of Airplane

100-00-1050

Section I
DESCRIPTION1. GENERAL.

The North American XP-51J Fighter Airplane is a single-place monoplane powered by an Allison Model V-1710-119 engine. The airplane has a wing span of 37 feet, an over-all length of 33 feet, and an approximate gross weight of 7400 pounds. It is armed with two fixed .50-caliber machine guns in each wing and may be equipped with wing racks to carry bombs, depth charges, or fuel tanks. Armor protection is shown in figure 5.

2. FLIGHT CONTROLS.

The ailerons, elevators, and rudder are conventionally operated by a control stick and rudder control pedals. Trim tabs on the ailerons, elevators, and rudder are manually operated by two control knobs (rudder and aileron tabs) and a control wheel (elevator tabs) located on a pedestal at the left side of the cockpit. A surface control locking device, furnished as loose equipment, may be attached to a bracket at the right side of the cockpit near the floor level to lock the control stick and rudder pedals. The wing flap control lever, located on a control pedestal below the instrument panel, provides simultaneous movement of the flaps with movement of the control lever. Flaps are automatically locked at any desired control lever setting until the lever is again moved. No provision is made for operating the wing flaps if the hydraulic system fails.

3. LANDING GEAR.

a. GENERAL. - The main landing gear and the tail wheel are actuated hydraulically by movement of the control lever located forward of the trim tab control pedestal at the left side of the cockpit. In case of hydraulic system failure, both gears will drop when the control lever is placed at the "DOWN" position and will be locked in their extended positions by bungees. After hydraulic retraction, the landing gear is held by the fairing doors which are mechanically locked by the landing gear control lever. The doors are locked when the lever is in neutral. During taxiing, with the control stick pulled aft, the tail wheel is maneuverable to 7 degrees right or left through movement of the rudder pedals. With the control stick pushed forward, the tail wheel is unlocked and will permit full rotation.

WARNING

Do not move the landing gear control lever when the airplane is on the ground and the engine is operating.

b. POSITION INDICATORS. - A red light and a green light on the left switch panel indicate the position of the landing gear. The red indicator illuminates when the gear is between the fully extended and fully retracted positions, and when the gear is in the fully retracted position with the throttle retarded to a position indicative of 16-19 in. Hg manifold pressure at 2000 rpm. The green indicator illuminates only when the main gear is fully extended and locked. Both lights should be out during normal flight. A fairing door warning light, located beneath the red and green landing gear lights on the left switch panel, illuminates when the fairing doors are unlocked.

4. BRAKES.

The hydraulic brakes are operated by pushing forward on the upper portion of the rudder control pedals. Fluid for the brake system is obtained from the main hydraulic reservoir. A parking brake control knob is on the lower right side of the center control pedestal.

5. HYDRAULIC SYSTEM.

The hydraulic system operates the main landing gear (extension and retraction), tail wheel (retraction only), wing flaps, brakes, sliding canopy, and the pilot's seat. Controls for the wing flaps, sliding canopy, and the seat are located on the control pedestal below the center switch panel. The canopy control lever may be moved from the "LOCK" to the "UNLOCK" position by pulling aft on the spring-loaded lock knob at the end of the control lever and moving the lever to the right. In this position, hydraulic fluid is by-passed to permit manual operation of the canopy. The seat and canopy controls are both spring-loaded and will return to their neutral positions when released.

6. POWER PLANT.

a. ENGINE. - The Allison Model V-1710-119 liquid-cooled engine incorporates a two-stage supercharger, a fuel injection pump, and an automatic manifold pressure regulator. The two-stage supercharger has a 7.54:1 low blower ratio, an 8.1:1 high blower ratio, and is automatically controlled by a boost control unit. The propeller reduction gear ratio is 2.36:1.

b. FUEL, OIL, AND COOLANT.

Fuel	Specification No. AN-F-28, Grade 100/130, Amend. No. 2
Oil	Specification No. AN-VV-0-466, Grade 1120 (S) or 1100 (W)
Coolant	Type D (70 percent water and 30 percent ethylene glycol, Specification No. AN-E-2, inhibited with NAMBT)

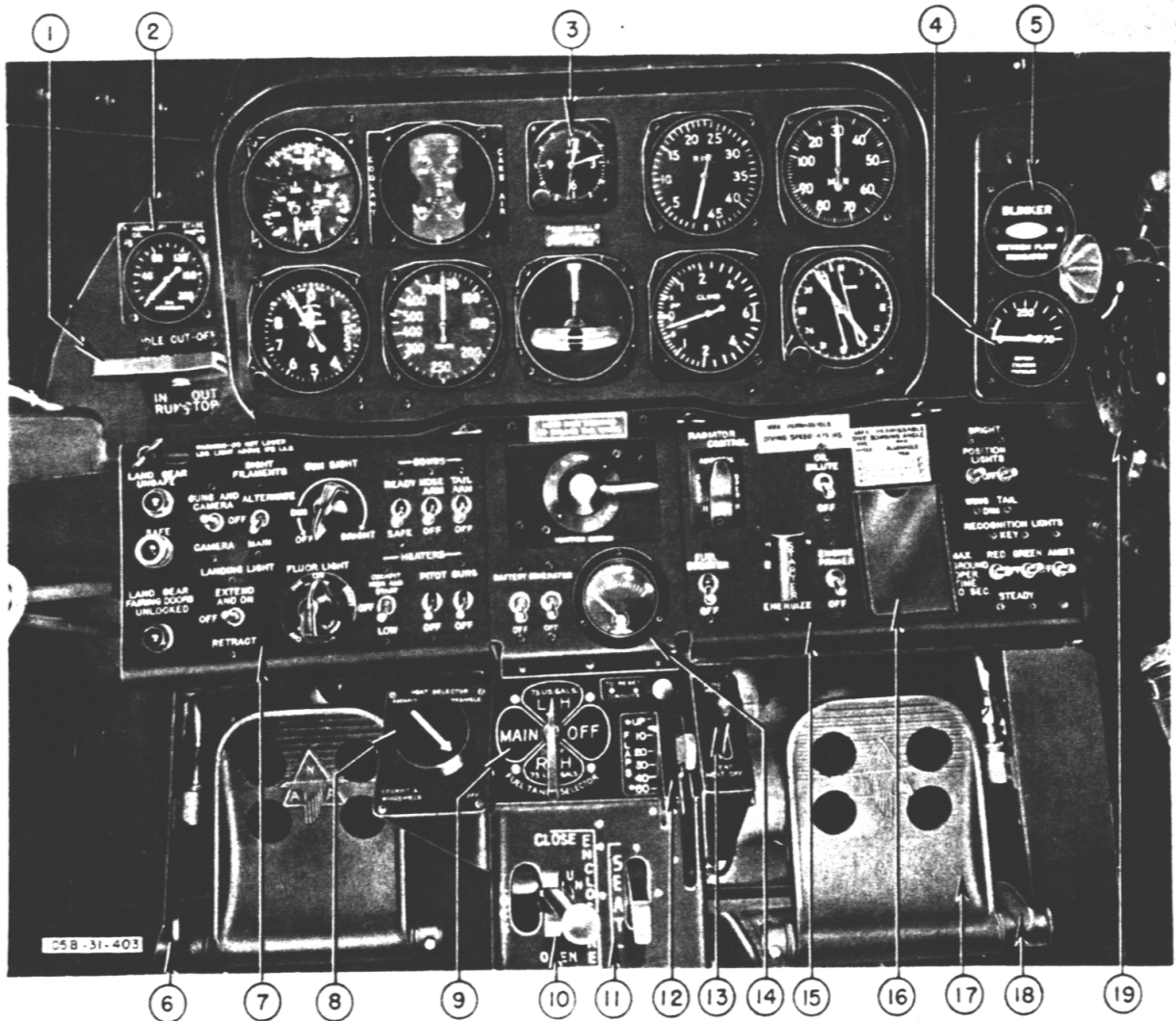

- | | |
|--------------------------------------|---|
| 1. IDLE CUT OFF CONTROL | 11. SEAL CONTROL |
| 2. AUXILIARY STAGE OIL PRESSURE GAGE | 12. WING FLAP CONTROL |
| 3. INSTRUMENT PANEL - SEE FIGURE 16 | 13. HEAT AND VENT CONTROL |
| 4. OXYGEN CYLINDER PRESSURE GAGE | 14. CENTER SWITCH PANEL - SEE FIGURE 18 |
| 5. OXYGEN FLOW INDICATOR | 15. RIGHT SWITCH PANEL - SEE FIGURE 18 |
| 6. RUDDER PEDAL ADJUSTMENT LEVER | 16. CARD HOLDER |
| 7. LEFT SWITCH PANEL - SEE FIGURE 18 | 17. RUDDER PEDAL |
| 8. HEAT SELECTOR CONTROL | 18. RUDDER PEDAL ADJUSTMENT LEVER |
| 9. FUEL SELECTOR CONTROL | 19. OXYGEN REGULATOR |
| 10. ENCLOSURE CONTROL | |

Figure 2—Cockpit - Forward View

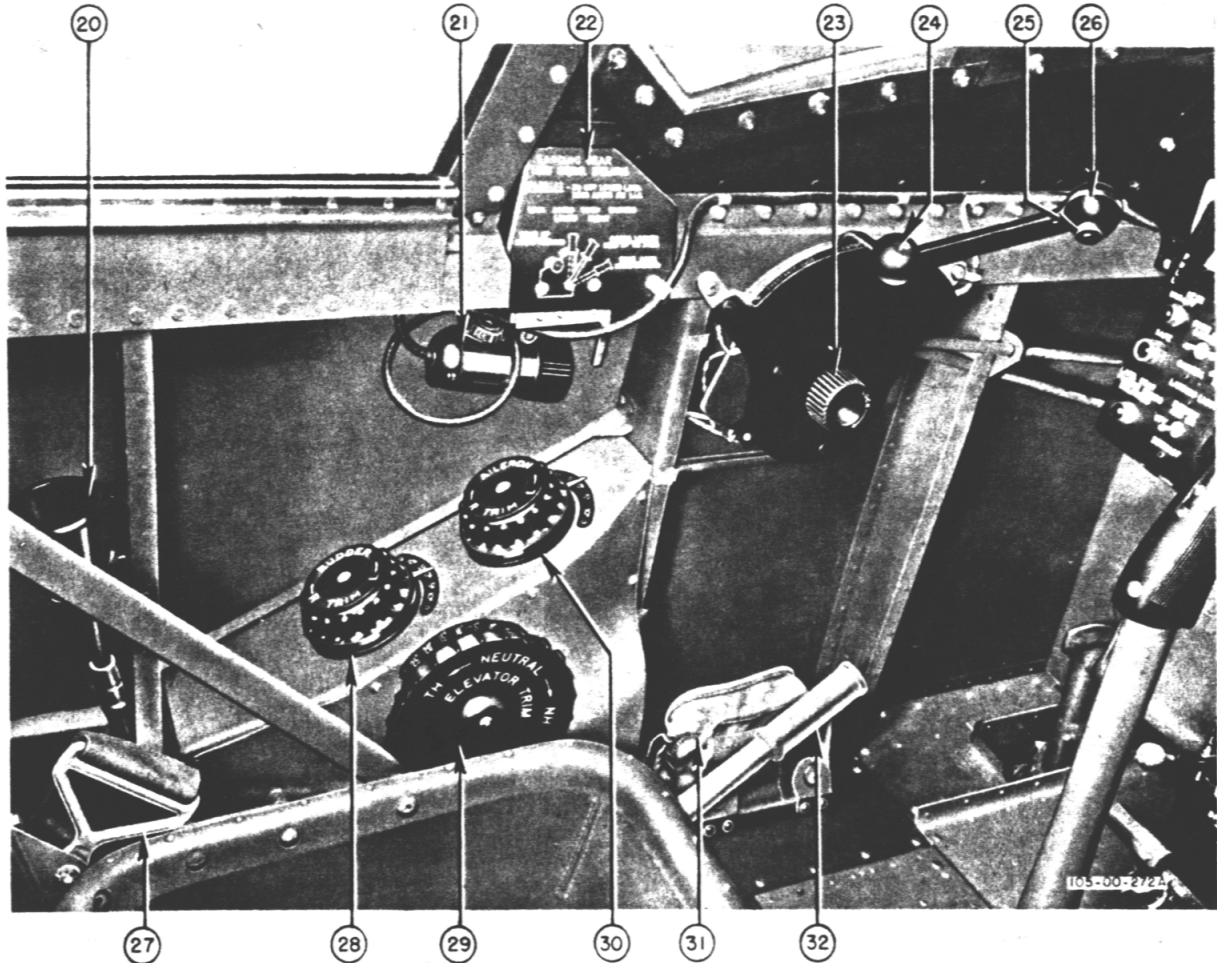

- 20. RELIEF TUBE
- 21. COCKPIT LIGHT
- 22. LANDING GEAR CONTROL INSTRUCTION PLATE
- 23. QUADRANT FRICTION LOCK
- 24. PROPELLER CONTROL
- 25. THROAT MICROPHONE SWITCH
- 26. THROTTLE
- 27. SAFETY BELT
- 28. RUDDER TRIM TAB CONTROL
- 29. ELEVATOR TRIM TAB CONTROL
- 30. AILERON TRIM TAB CONTROL
- 31. PYROTECHNIC SIGNAL PISTOL CARTRIDGE CASE
- 32. LANDING GEAR CONTROL

Figure 3—Cockpit - Left Side

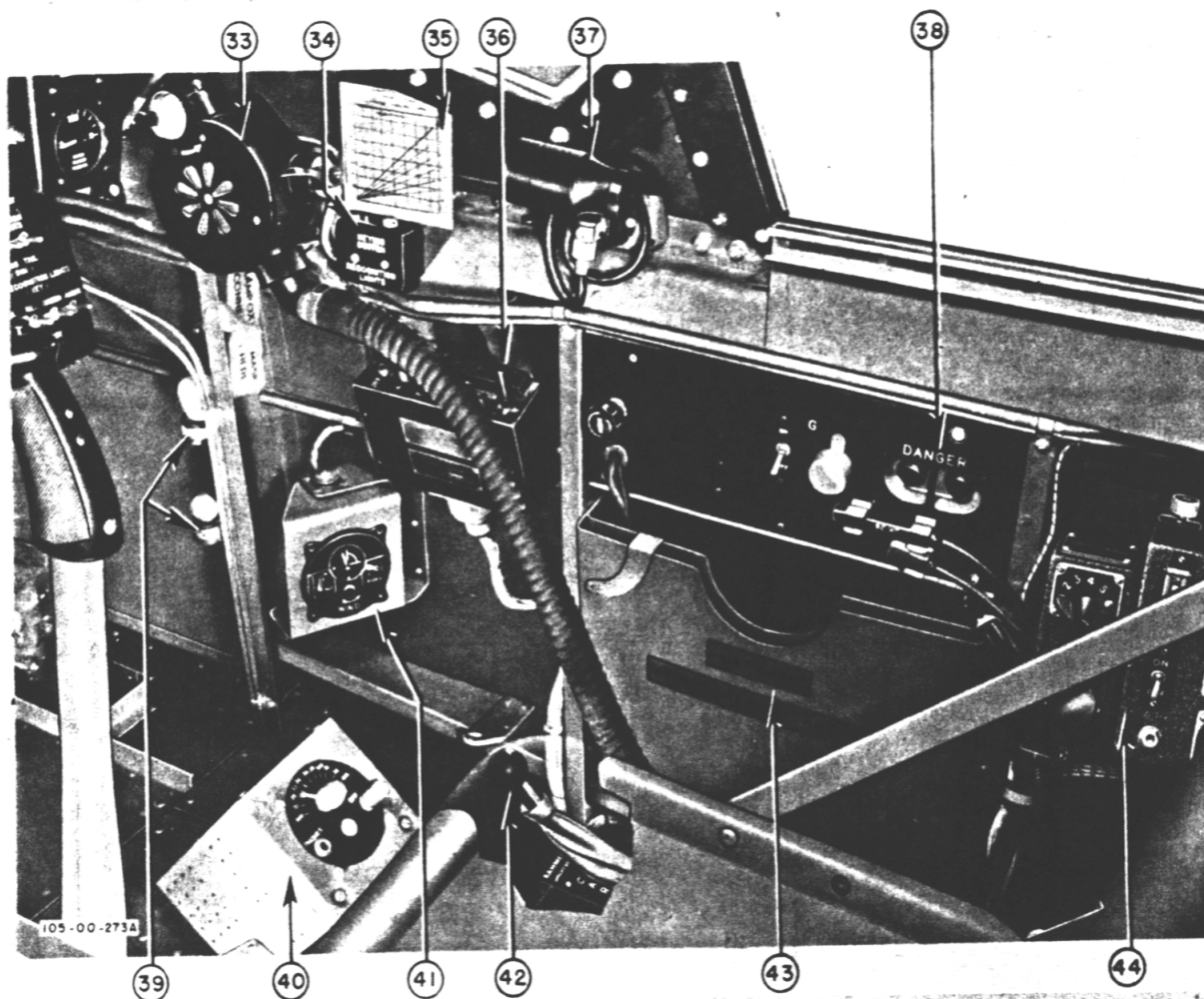

- 33. OXYGEN REGULATOR
- 34. RECOGNITION LIGHTS KEYING SWITCH
- 35. OXYGEN CONSUMPTION CHART
- 36. SCR-522-A CONTROLS
- 37. FLUORESCENT LIGHT
- 38. DETONATOR SWITCHES
- 39. SPARE LAMP STOWAGE
- 40. DETROLA RECEIVER
- 41. REMOTE CONTACTOR
- 42. CARBURETOR AIR CONTROL
- 43. MAP CASE AND FLIGHT REPORT HOLDER
- 44. SCR-695-A CONTROLS

Figure 4—Cockpit - Right Side

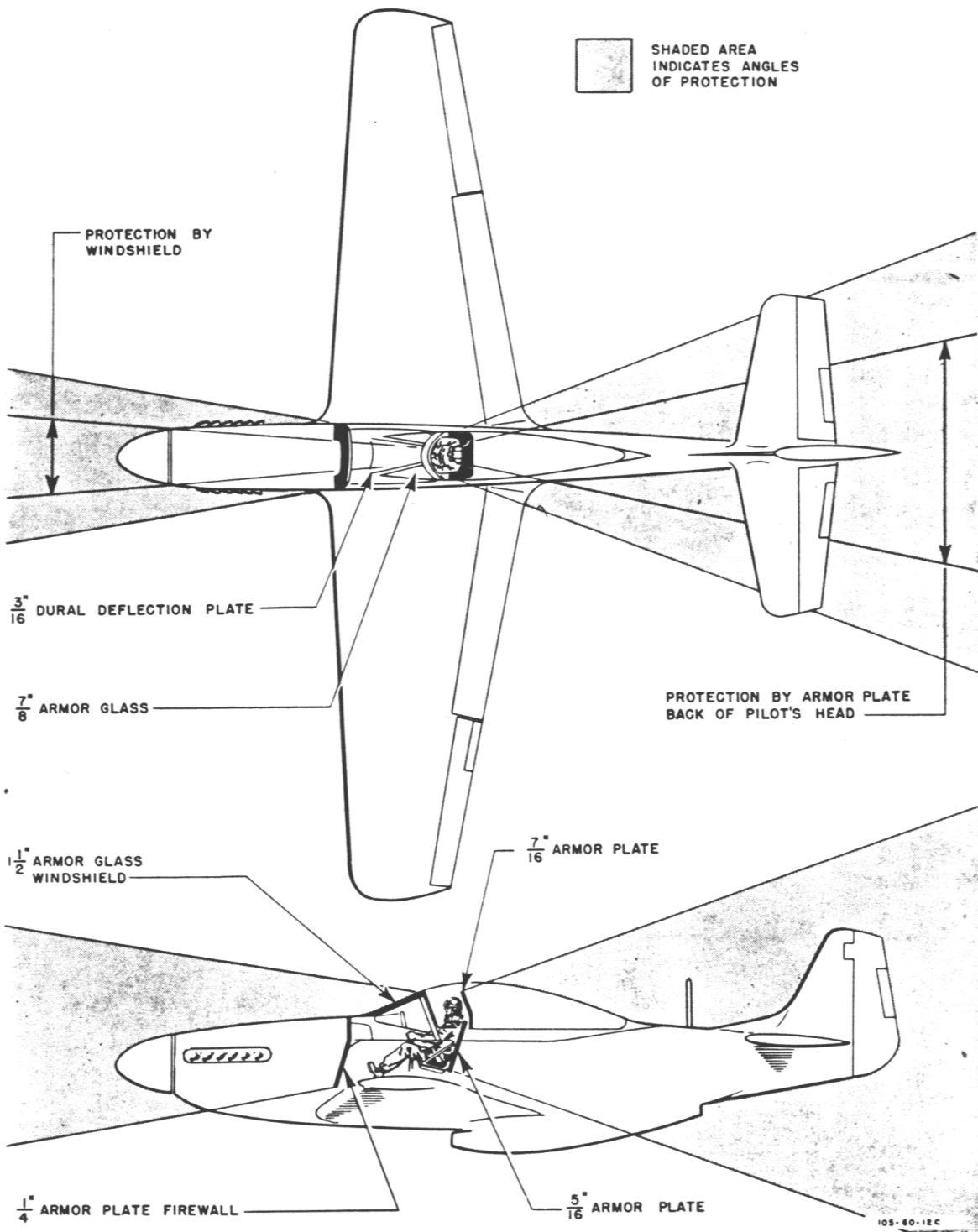

Figure 5—Armor Protection

Note

For operation at temperatures below -12°C ($+10^{\circ}\text{F}$), use Type C coolant (30 percent water and 70 percent ethylene glycol, Specification No. AN-E-2, inhibited with NAMBT).

c. PROPELLER. - A four-blade, hydraulically operated, constant-speed Aeroproducts propeller is used on this airplane. The diameter of the propeller is 11 feet, 1 inch.

d. ENGINE CONTROLS.

(1) THROTTLE AND PROPELLER CONTROLS. - The throttle and the propeller controls are operated independently. War emergency power is obtained by moving the throttle forward past the control joggle stop at the maximum normal rpm position. The propeller control may be moved fore and aft to either "INCREASE RPM" or "DECREASE RPM." Both controls are located at the left side of the cockpit.

(2) IDLE CUTOFF CONTROL. - This is a cam type of control located on the left side of the instrument panel. Two positions are provided: an extreme forward (pushed in) for operating the engine, and an extreme rear (pulled out) for starting and stopping the engine.

e. CARBURETOR AIR. - The air induction system supplies the carburetor with rammed cold air, unrammed warm air from the engine compartment, or unrammed filtered air. The carburetor air control lever is located to the right of the seat at the floor level. When the control lever is moved to "RAMMED," only rammed cold air enters the carburetor. When the control is moved to "FILTERED," air enters the induction system through a filtering unit installed in the baggage compartment. If the air duct becomes obstructed by ice, unrammed warm air from the engine compartment will enter the induction system automatically through the spring-loaded hot air door.

Note

If operational conditions make the use of filtered air unnecessary, the filter section of the air duct may be replaced by the baggage compartment door. When the door is installed, movement of the control lever to "FILTERED" will automatically admit engine compartment air to the carburetor. If more heat is required, move the lever to the hot air position.

7. FUEL SYSTEM.

Fuel is supplied to the engine from a fuel cell in each wing or from two auxiliary combat tanks (when installed) on the wing racks. The right wing cell has a capacity of 105 US (87.5 Imperial) gallons and the left wing cell holds 75 US (62.4 Imperial) gallons. The auxiliary tanks hold 75 US (62.4 Imperial) gallons each. Fuel is supplied from the left wing cell (when installed) through a gravity feed to the right wing cell, and is then pumped to the engine by a submerged-type booster pump. A uniform fuel level is always maintained in both cells. Fuel in the combat tanks is pressurized by the engine superchargers; the tank pressures are controlled by a spring-loaded valve to limit the pressure to 5 pounds per square inch. A fuel tank selector control is located on the control pedestal below the center switch panel and a booster pump control switch on the right switch panel. Turning the fuel tank selector control from "MAIN" to any other position automatically shuts off the booster pump.

Note

The normal fuel capacity of the airplane is 105 US (87.5 Imperial) gallons which are carried in the right wing cell only. When tactical missions do not require a greater fuel load, it is permissible to remove the left wing cell to reduce the gross weight of the airplane.

8. OIL SYSTEM.

The oil tank, mounted on the forward face of the firewall, has a total capacity of 15-3/4 gallons and an actual capacity of 14 gallons. Approximately one gallon of oil is forced into the heat exchanger when the engine is started. Scavenge pumps are provided in the engine sump to return oil directly from the engine, through the heat exchanger and a thermostatic control valve, to the oil tank. When a temperature of 85°C (185°F) is obtained, the thermostatic control valve closes to divert the oil through the heat exchanger. This valve also functions as a by-pass valve, and will open when a surge pressure of 40 pounds per square inch is reached. The oil dilution system is controlled by a switch located on the right switch panel.

9. COOLING SYSTEMS.

Two separate cooling systems are provided; one system cools the supercharger fuel-air mixture and the engine oil, and the other system cools the engine. Each system has an expansion tank, a radiator section, and a pump. The engine coolant radiator and aftercooling system radiator are constructed as a unit and are located in the air scoop. A thermostatically

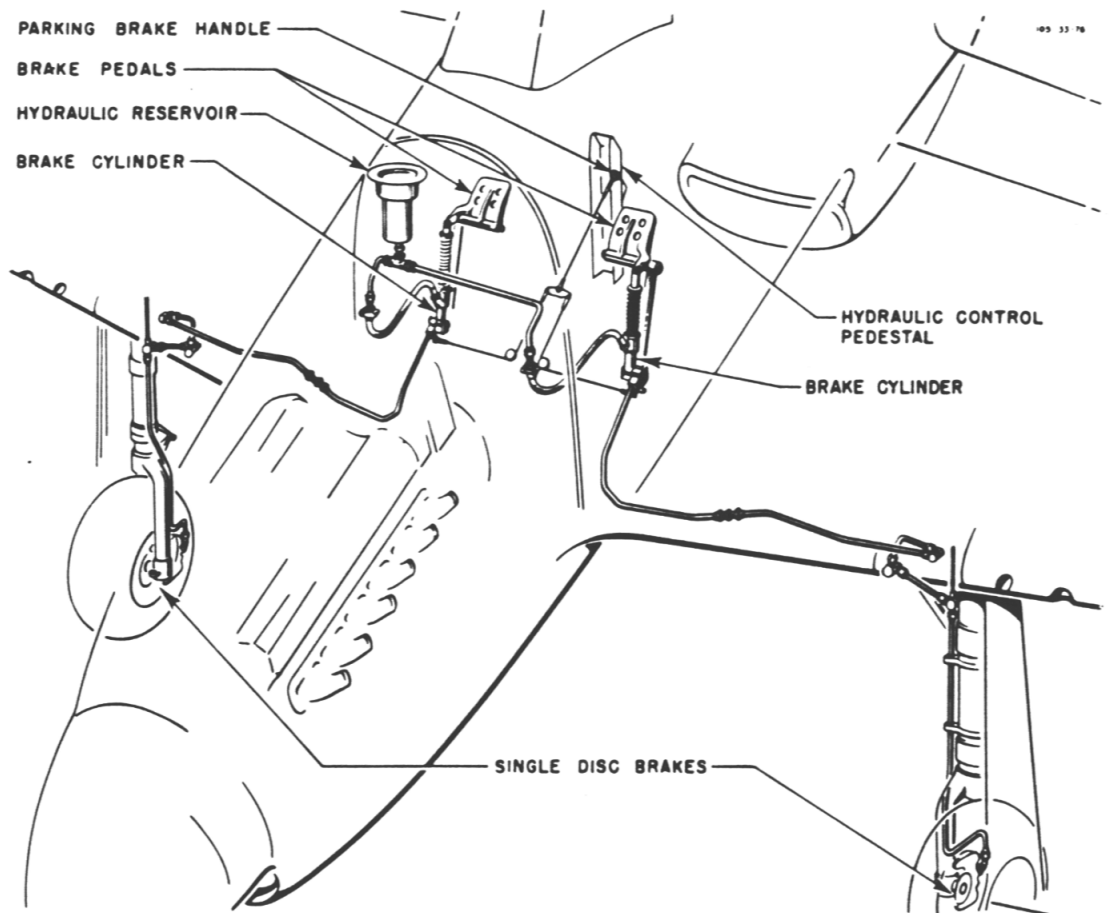
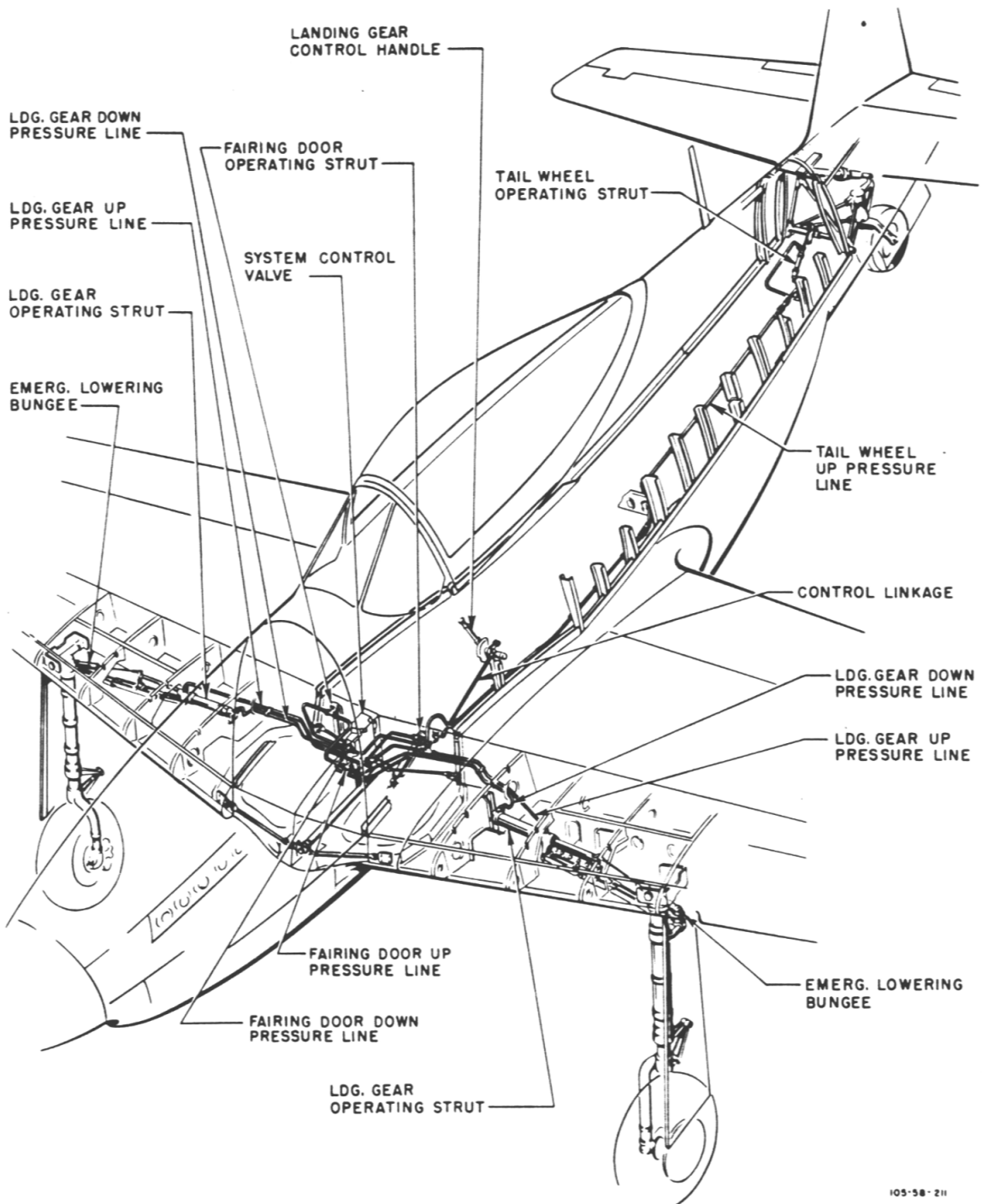
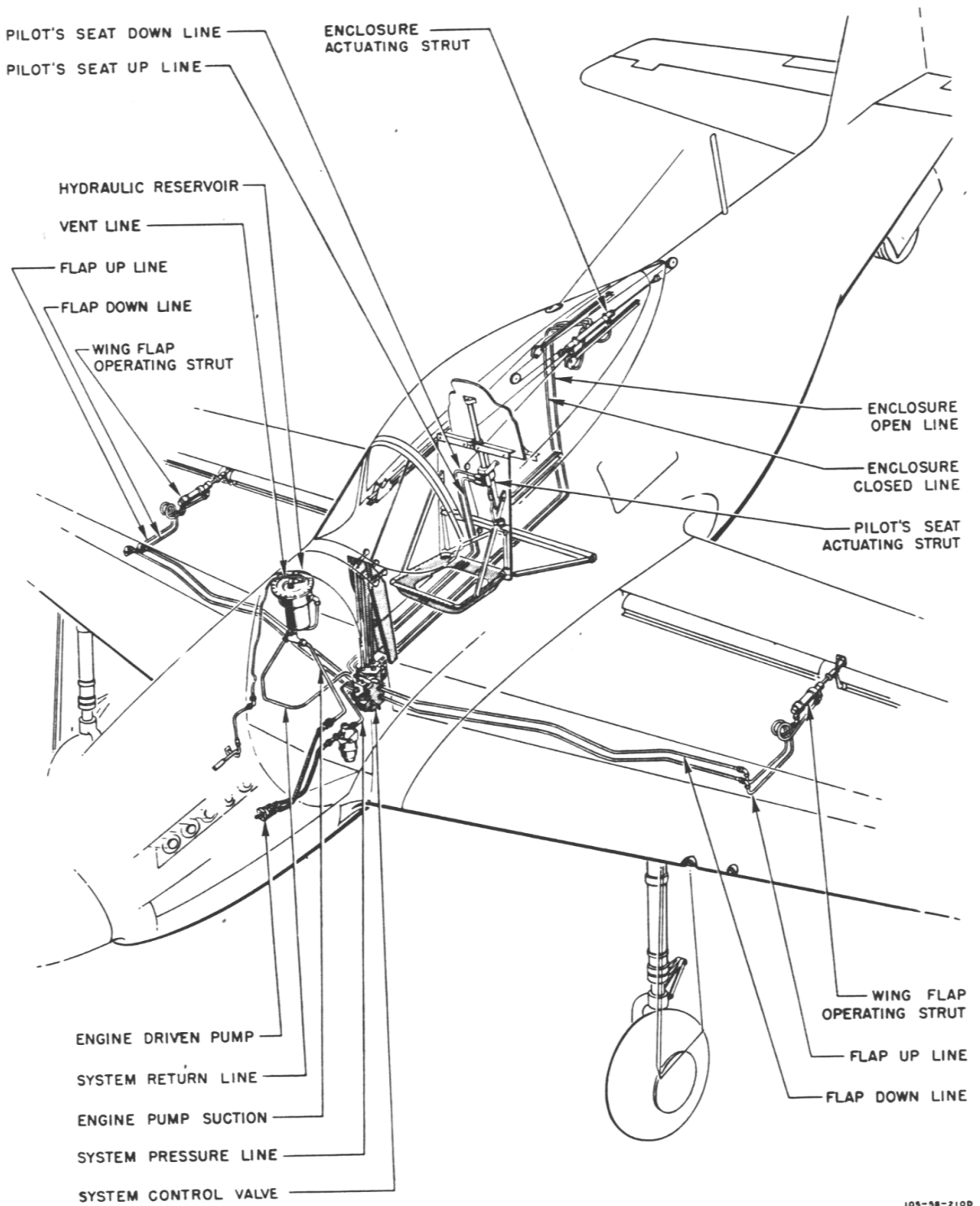

Figure 6—Brake System



105-58-211

Figure 7—Landing Gear Hydraulic System



105-58-2100

Figure 8—Hydraulic System - Power, Wing Flaps, Seat and Enclosure

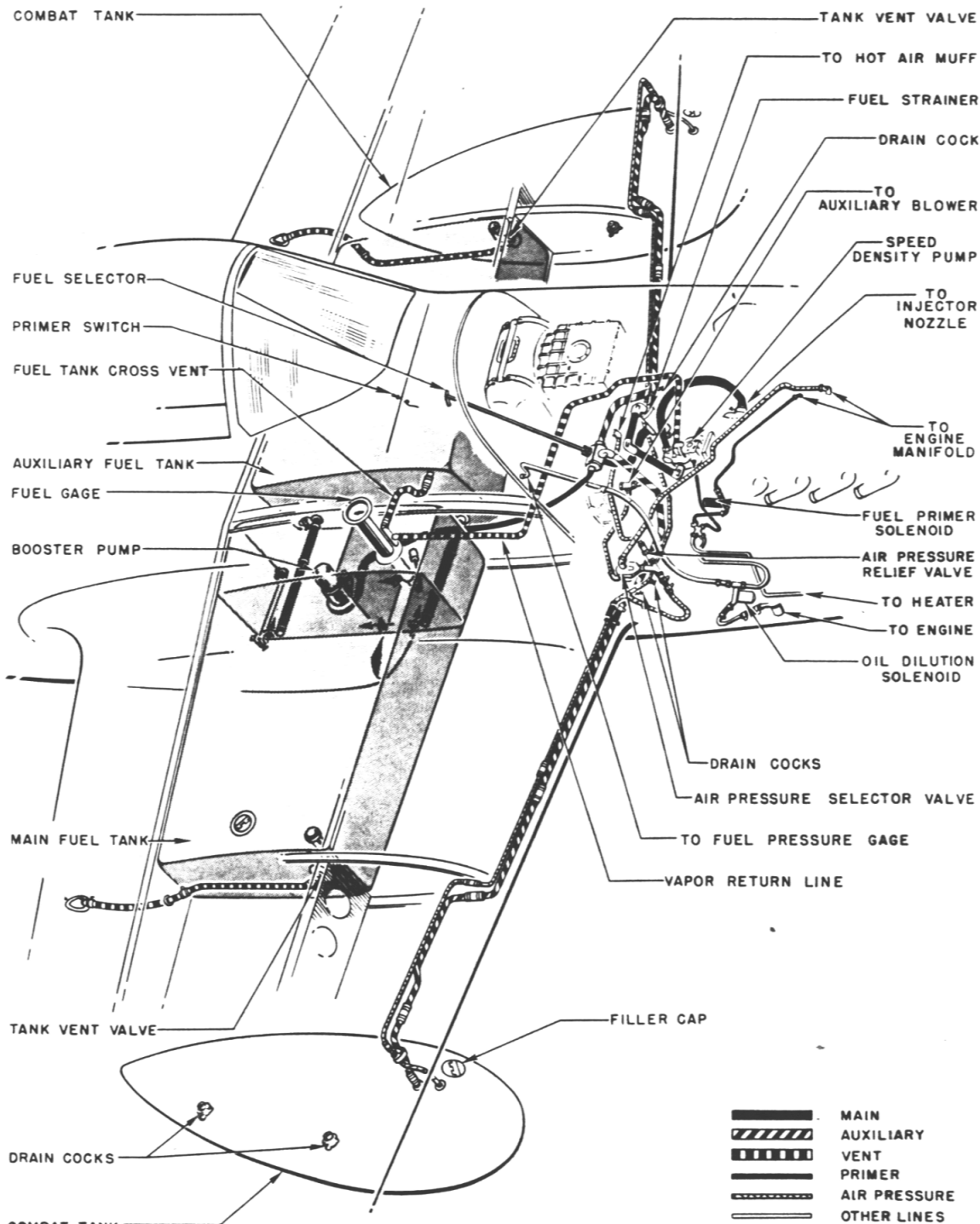

109A-48-176A

Figure 9—Fuel System

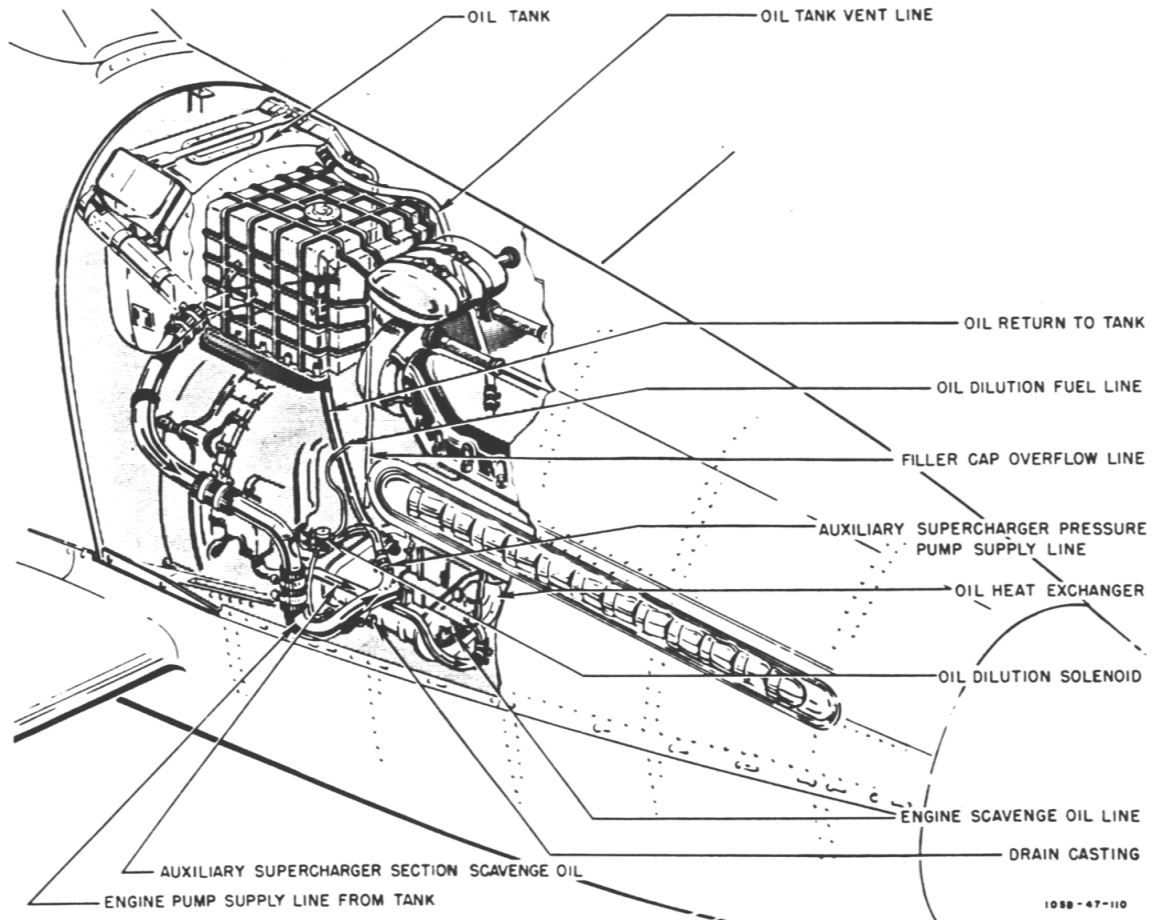

Figure 10—Oil System

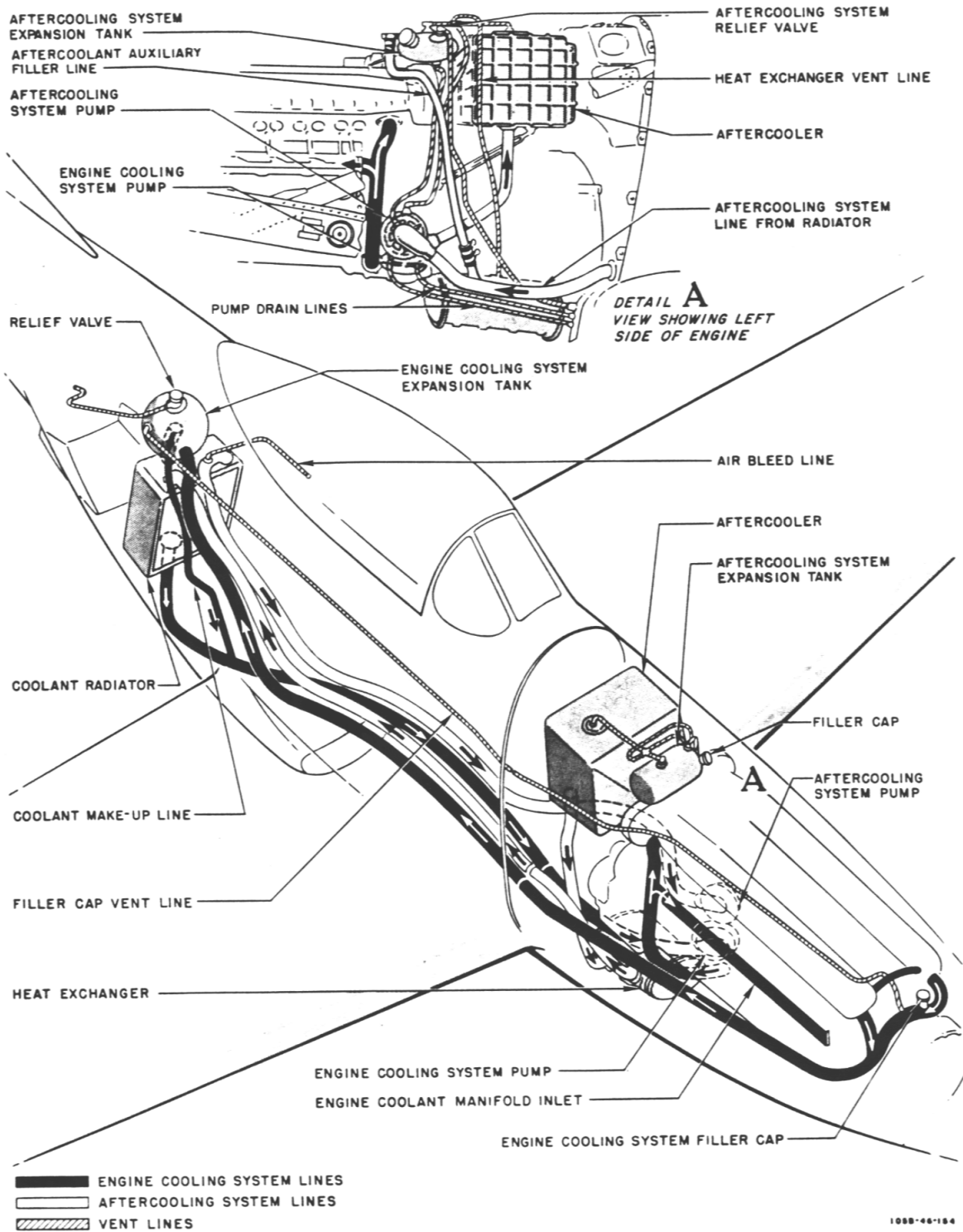

Figure 11—Cooling Systems

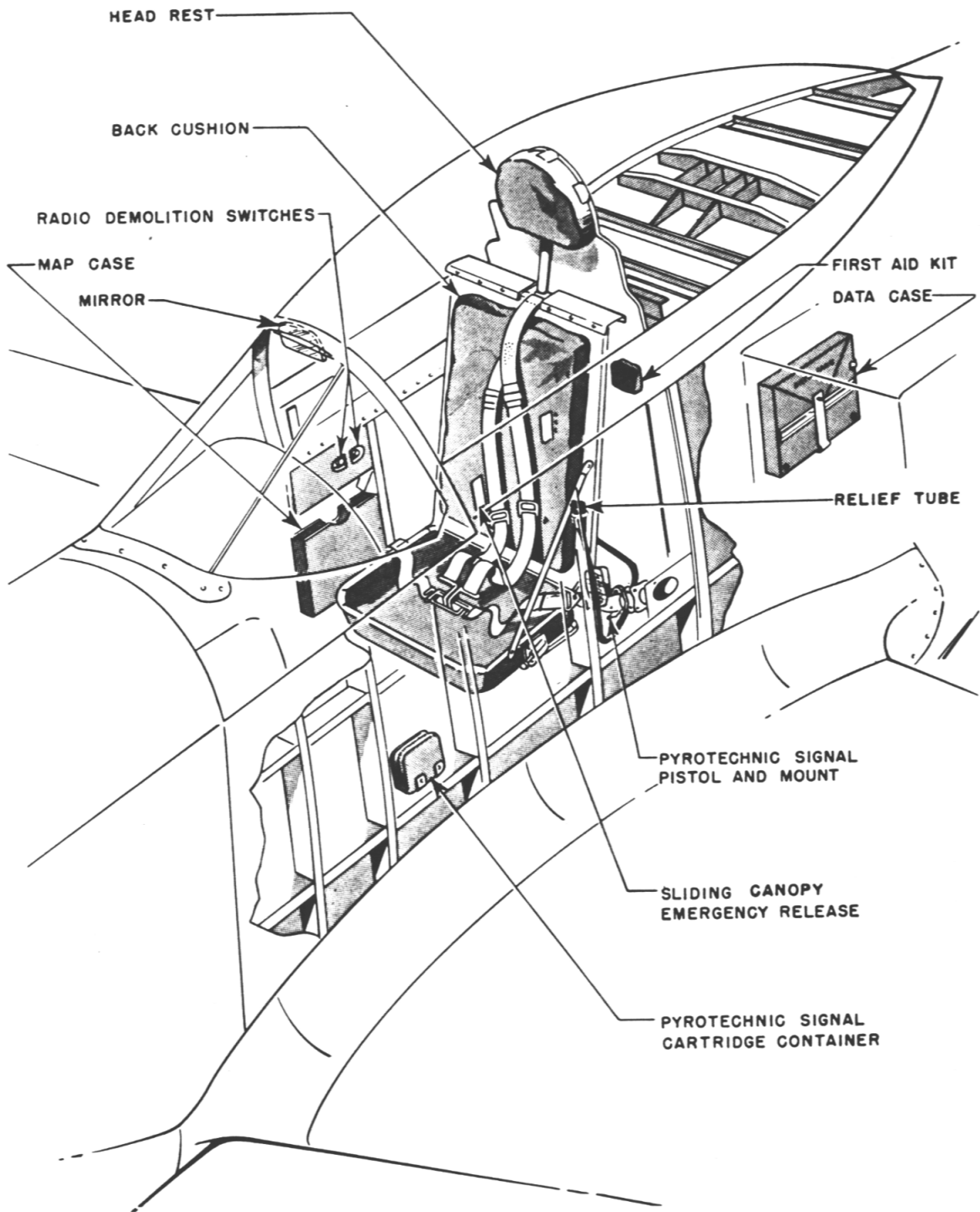

Figure 12—Miscellaneous and Emergency Equipment

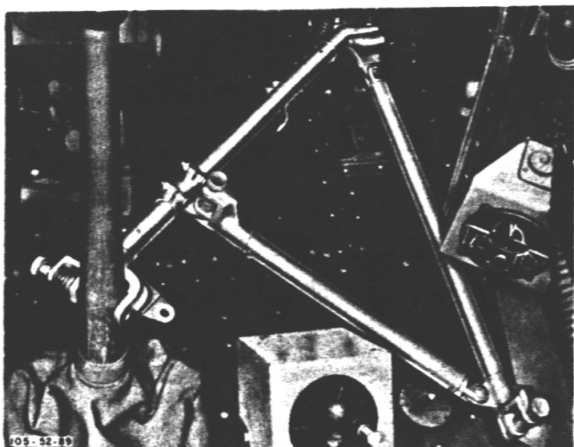

Figure 13 - Surface Control Lock

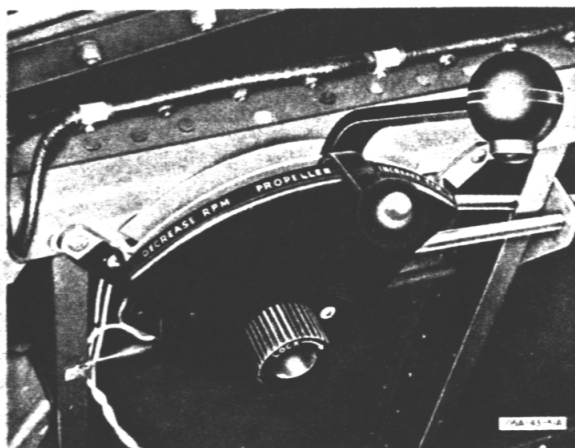

Figure 14 - Engine Controls

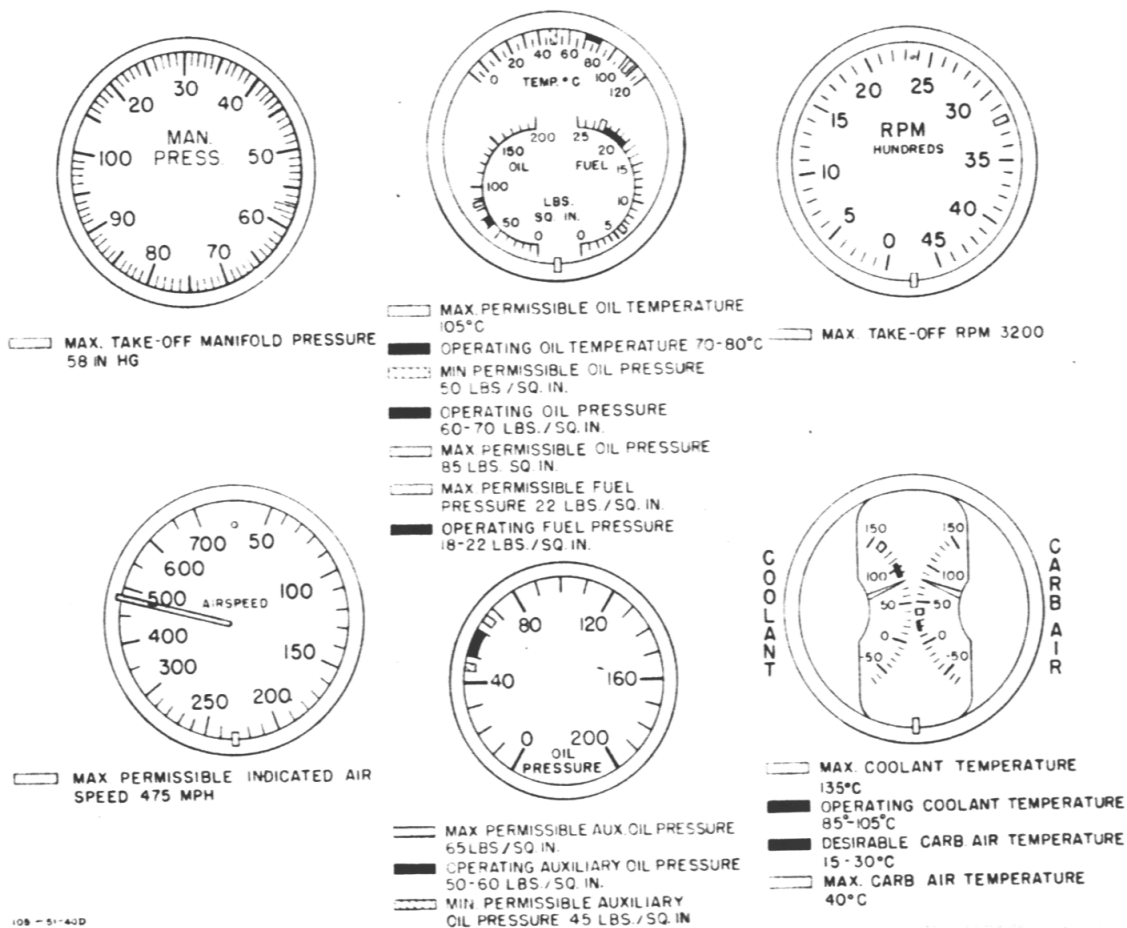

Figure 15 - Instrument Limitations

controlled, electrically operated outlet flap regulates the flow of air through the radiator.

10. ELECTRICAL SYSTEM.

The electrical system is of the 24-volt, direct-current, single-wire type using the structure of the airplane as a common ground return circuit. An engine-driven generator, regulated to a 28-volt output by a voltage regulator, supplies power to charge the battery and to operate the units of electrical equipment. An external power socket is located on the left side of the fuselage above the trailing edge of the wing for inducting external power when operating the electrical system on the ground. Electrical power for the starter motor is supplied only through this external socket. All electrical control switches are mounted on three panels directly below the instrument panel; a master circuit breaker reset button is located on the control pedestal below the center switch panel.

Section II
PILOT'S OPERATING INSTRUCTIONS1. FLIGHT RESTRICTIONS.a. MANEUVERS PROHIBITED.

(1) Inverted flying must be limited to 10 seconds because of loss of oil pressure and failure of the scavenge pumps to operate in an inverted position.

b. AIRSPPEED LIMITATIONS.

- (1) The maximum permissible diving speed is 475 IAS.
- (2) Do not extend landing gear above 170 IAS.
- (3) Do not lower flaps fully above 160 IAS.
- (4) Do not lower landing light above 170 IAS.

2. BEFORE ENTERING COCKPIT.

a. Make sure the airplane has been serviced and is ready for flight, particularly in regard to proper quantities of fuel, oil, coolant, hydraulic fluid, and oxygen.

b. Make sure the total weight of fuel, oil, ammunition, and special equipment carried is suited to the mission to be performed. This is most important as the rate of climb of the airplane may vary, depending on the load carried.

c. Maximum safe manifold pressure for ground run-up, without using tail anchorage, has not been determined prior to this publication. Securely anchor the tail of the airplane and use wheel chocks, if available, when excessive manifold pressures are required during run-up.

d. Make sure external power supply (if available) is connected.

e. The sliding canopy may be opened from either side by pushing in on the spring-loaded door at the forward end and sliding the canopy aft.

3. ON ENTERING COCKPIT.

a. The following procedures should be carried out prior to all flights:

- (1) Make sure ignition switch is "OFF."

(2) Remove surface control lock as follows:

(a) Pull out on spring-loaded plunger on left side of the control stick, and move stick aft.

(b) Pull up on plunger on the control lock at the right side of the cockpit, and move lock slightly inboard.

(c) Pull up on plunger on center of control lock, fold control lock flat, and unhook lock from rudder pedal.

(d) Hand control lock to ground personnel.

Note

The surface control lock is not carried in the airplane, except on ferrying flights.

(e) Check the controls for free and proper movement, watching control surfaces for correct response.

(3) Adjust rudder pedals for proper leg length so as to obtain full brake control while taxiing. Adjustment is made by pressing the lever located on the outer side of each rudder pedal.

(4) Push in on circuit reset button on control pedestal.

(5) Set parking brakes by pulling out the knob below the center of the control pedestal, depressing the brake pedals, and then releasing the handle.

(6) Make sure gun and bomb switches on left switch panel are "OFF," and spring safety lock is in place on emergency bomb release handle.

(7) Make sure landing gear control handle on left side of cockpit is in neutral position, and landing gear "SAFE" indicator light is illuminated.

(8) Set altimeter to correct barometric pressure.

(9) Test gun sight illumination by turning gun sight filament switch to "MAIN" and operating rheostat control on left switch panel.

(10) Check remote-indicating compass for correct reading.

b. When night flying is anticipated, make the following additional checks:

(1) Test fluorescent instrument light on right longeron by operating rheostat control on left switch panel.

(2) Position cockpit light under left longeron by pulling aft on the light bracket and swinging bracket inboard to the locked position. Test light by operating switch and rheostat on the lamp housing.

(3) Test position lights by moving switches on right switch panel to "BRIGHT" and "DIM."

(4) Test landing light (with aid of outside observer) by moving landing light switch on left switch panel to "EXTEND AND ON." After testing light, move switch to "RETRACT" and then to "OFF."

(5) Test recognition lights by operating the switches on right switch panel and the keying switch on right longeron.

Note

Do not operate recognition lights longer than 10 seconds on the ground.

4. STARTING ENGINE.

a. Start the engine as follows:

(1) Connect external power supply.

(2) See that ignition, battery, and starter switches are "OFF."

(3) Move generator-disconnect switch on center switch panel to "GENERATOR."

(4) See that idle cutoff control, on left side of instrument panel, is pulled out.

(5) Have ground personnel turn propeller several revolutions by hand.

(6) Open throttle one inch.

(7) Move propeller control to full "INCREASE RPM."

(8) See that radiator air control switch on right switch panel is in "AUTOMATIC."



CSB-5-14

Figure 16—Instrument Panel

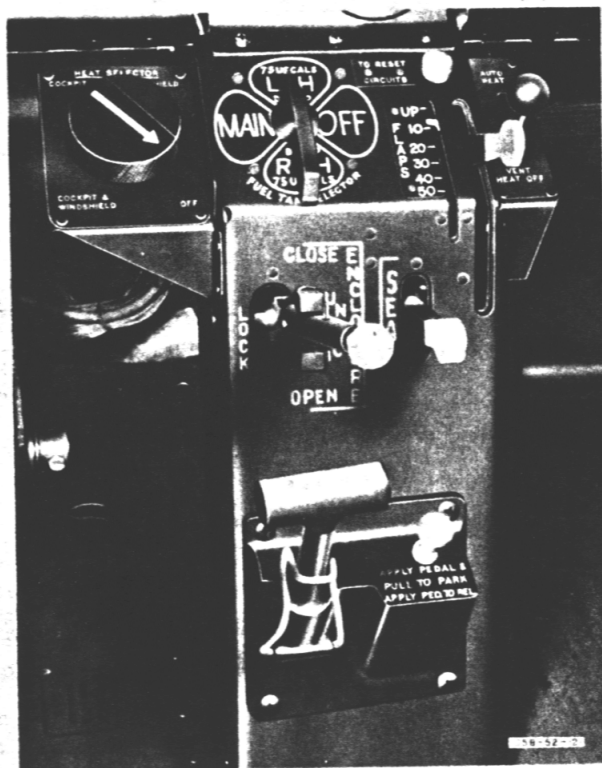

Figure 17—Control Pedestal
CONFIDENTIAL

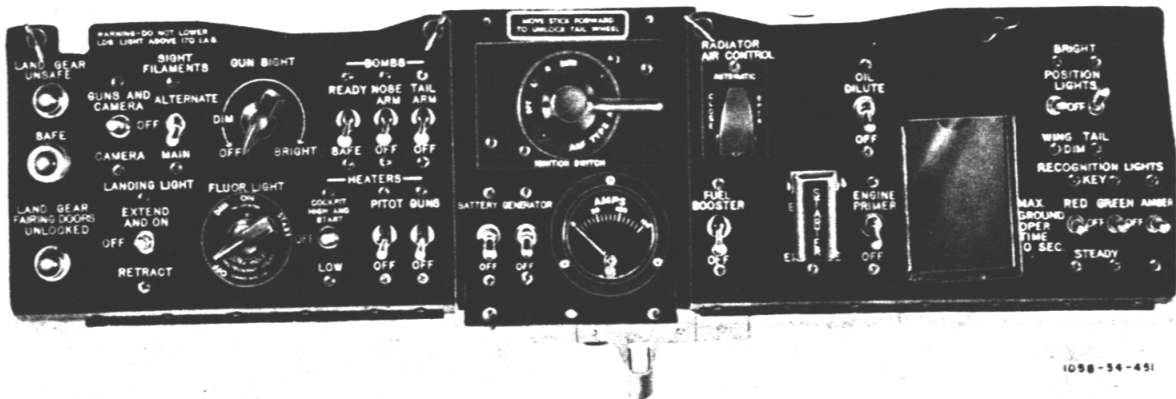

Figure 18—Switch Panels

NOTE:

THE COMBAT TANKS ARE SELECTED BY THE SAME SELECTOR VALVE, BUT HAVE NO BOOSTER PUMP. A CONTROLLED AIR PRESSURE OF 5 LBS / SQ IN. IS MAINTAINED WITHIN THE COMBAT TANKS.

NOTE:

TURNING FUEL SELECTOR VALVE FROM MAIN TO ANY OTHER POSITION AUTOMATICALLY SHUTS OFF THE BOOSTER PUMP.

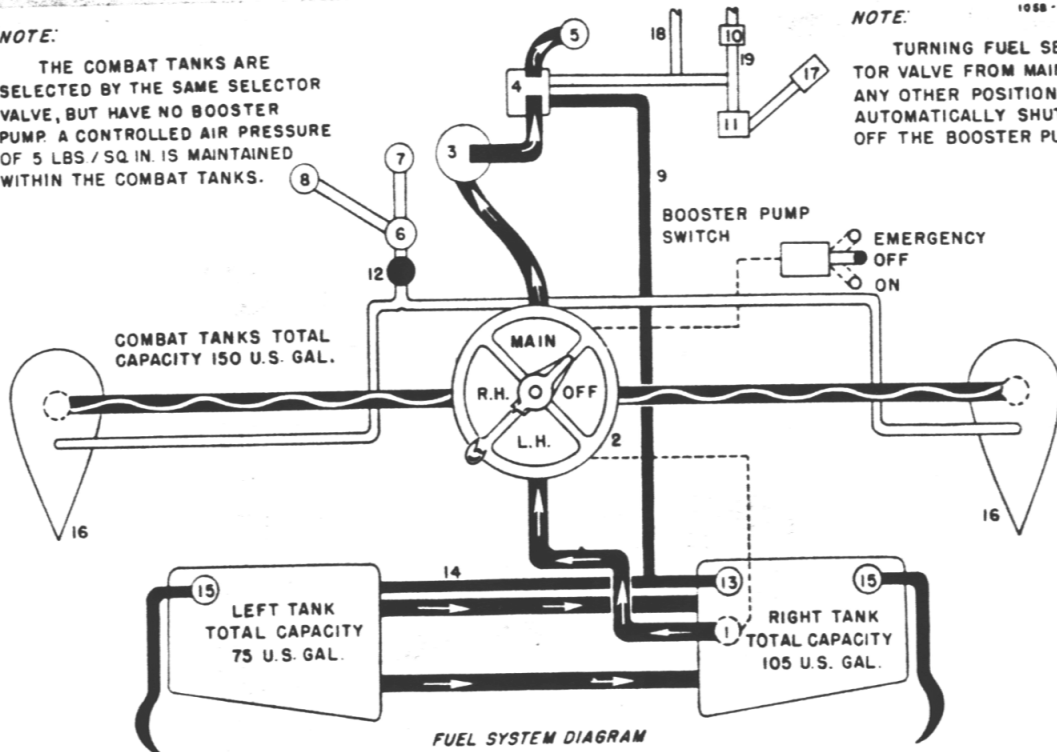

FUEL SYSTEM DIAGRAM

LINE CODE

- MAIN
- AUXILIARY
- VENT
- OTHER LINES
- ELECTRICAL WIRING

- 1. BOOSTER PUMP
- 2. FUEL SELECTOR VALVE
- 3. FUEL STRAINER
- 4. SPEED DENSITY PUMP
- 5. INJECTOR NOZZLE
- 6. AIR PRESSURE SELECTOR VALVE
- 7. MANIFOLD PRESSURE
- 8. AUXILIARY BLOWER PRESSURE
- 9. PUMP VAPOR RETURN
- 10. FUEL PRIMER SOLENOID
- 11. OIL DILUTION SOLENOID
- 12. AIR PRESSURE RELIEF VALVE (SET TO 5 POUNDS)
- 13. FUEL GAGE
- 14. FUEL TANK CROSS VENT
- 15. VENT VALVE ASSEMBLY
- 16. DROPPABLE COMBAT TANKS
- 17. OIL DRAIN CASTING
- 18. FUEL TO HEATER
- 19. PRIMER LINE TO ENGINE

Figure 19—Fuel System Line Diagram

(9) Move carburetor air control at right lower side of cockpit to "RAMMED" ("FILTERED," if required).

(10) Turn fuel selector control at top of control pedestal to "MAIN," and fuel booster pump switch on right switch panel to "ON." Check fuel pressure gage for 13-15 pounds per square inch pressure.

(11) Push engine primer switch on right switch panel to "ENGINE PRIMER." Prime engine 3 seconds when cold, 2 seconds when hot.

(12) Turn ignition switch to "BOTH."

(13) Press starter switch to "ENERGIZE" until maximum speed is reached, then to "START." Prime engine while starting, as required.

Note

External power must be used to start the engine with the starter, as electrical power for the starter motor is supplied through the external power receptacle only. If external power is not available, use handcrank.

(14) As engine starts, push in idle cutoff control. Prime engine intermittently for smooth operation.

WARNING

When engine is not firing, the idle cutoff control must be out.

(15) Check oil pressure. If pressure is not up to 50 pounds per square inch within 30 seconds, stop engine and investigate.

(16) Push battery switch to "BATTERY."

(17) Adjust seat level to obtain full travel of the rudder pedals in the extreme positions. The seat is adjusted by moving seat control handle on the control pedestal either "UP" or "DOWN." When the desired position is reached, release handle; it will return to the neutral position.

5. ENGINE WARM-UP.

Warm up the engine at 1300 rpm until the oil temperature shows a definite increase and the oil pressure remains steady when the throttle is opened.

	DESIRED	MAXIMUM
Oil temperature	73-85°C (Grade 1120) 69-70°C (Grade 1100)	105°C (Grade 1120) 90°C (Grade 1100)
Coolant temperature	105-121°C	125°C
Oil pressure	60-70 lbs./sq.in.	85 lbs./sq.in.

The desired oil and coolant temperatures will be maintained by having the radiator air control switch in "AUTOMATIC." If coolant and oil temperatures exceed limits with control in "AUTOMATIC," shut off engine and investigate.

6. SCRAMBLE TAKE-OFF.

Use oil dilution to obtain proper oil pressure at moderate power, and as soon as the engine will take the throttle, taxi out and take off.

Note

Overdilution is likely to result under these conditions because of low oil flow and a cold engine which holds back evaporation. If dilution is used, close observation of the oil pressure will be necessary during the time of dilution and take-off to determine whether or not the oil has been overdiluted, resulting in low oil pressure, and loss of oil through the engine breather.

7. ENGINE AND ACCESSORIES GROUND TEST.

a. After the engine has been warmed up sufficiently, proceed with these tests:

(1) Check fuel flow from external tanks (if installed) by rotating fuel selector control.

(2) Visually check operation of wing flaps by operating flap control on hydraulic control pedestal.

(3) Check operation of radiator air exit flap (with assistance of outside observer) using override positions of radiator air control switch. Return switch to "AUTOMATIC."

(4) Check communication equipment for proper operation.

(5) At 2200 rpm, check the instruments for the following limitations:

	DESIRED	MINIMUM	MAXIMUM
Oil pressure	60-70 lbs./sq.in.	55 lbs./sq.in.	35 lbs./sq.in.
Auxiliary stage oil pressure	50-60 lbs./sq.in.	45 lbs./sq.in.	65 lbs./sq.in.
Oil temperature	70-85°C (Grade 11Z)		105°C (Grade 1120)
	60-75°C (Grade 1100)		90°C (Grade 1100)
Coolant temperature	105-121 C		125°C
Coolant temperature (Take-off and combat)			135°C
Fuel pressure	23 lbs./sq.in.		27 lbs./sq.in.
Ammeter			100 amperes

(6) At 2200 rpm, check magnetos. A maximum loss of 100 rpm is allowable.

(7) At 2200 rpm, move propeller control back to note 300 rpm drop (maximum); then move forward to full "INCREASE RPM." Manifold pressure should remain constant within one in. Hg.

(8) Notify ground personnel to release tail, remove wheel chocks, and disconnect external power source.

(9) Close sliding canopy by pulling out on the spring-loaded control handle on the control pedestal, and moving handle to "CLOSE." When canopy reaches desired position, release handle. The handle is spring-loaded to return to the neutral position.

8. TAXIING INSTRUCTIONS.

a. Observe the following generalities when taxiing:

(1) Raise the wing flaps.

WARNING

To prevent damage to the wing flaps, they must be up when taxiing. In addition, always taxi cautiously so as to avoid damage from objects which the tires might pick up and throw against the radiator air-scoop flap.

(2) Steer a zigzag course to obtain an unobstructed view.

(3) Taxi with the stick slightly aft of neutral to lock the tail wheel. In the locked position, the tail wheel may be turned 7 degrees to the right or left by using the rudder pedals. For sharp turns, push the stick forward of the neutral position to allow the tail wheel full swiveling action.

(4) Use the brakes as little as possible, and always taxi cautiously.

(5) Upon reaching the take-off position, stop the airplane cross-wind so that approaching airplanes may be plainly seen.

9. BEFORE TAKE-OFF.

a. Follow this sequence of operations before take-off:

- (1) Check flying controls for free movement (look at control surfaces).
- (2) Set rudder trim 5 degrees to the right, elevator trim 0 degrees, aileron trim 0 degrees.
- (3) Move propeller control to full "INCREASE RPM."
- (4) Check fuel level.
- (5) See that fuel selector valve is on "MAIN," and that booster pump switch is "ON" (pressure 23-27 pounds).
- (6) Radiator air control "AUTOMATIC."
- (7) Carburetor air control "RAMMED." ("FILTERED" or "HOT AIR" if required.)
- (8) Check enclosure for security of attachment.

10. TAKE-OFF.

a. When take-off area is clear, quickly check the following:

- (1) Wing flaps 15-20 degrees down for best obstacle clearance.
- (2) Oil pressure 55 pounds per square inch minimum.
- (3) Auxiliary stage oil pressure 45 pounds per square inch minimum.
- (4) Oil temperature 40°C minimum, 105°C maximum (Grade 1120), 90°C maximum (Grade 1100).
- (5) Coolant temperature 85°C minimum, 135°C maximum for take-off and combat.

b. Open throttle to gate for take-off.

Note

Do not attempt to lift the tail too soon, as this increases the torque action. Pushing the stick forward unlocks the tail wheel, thereby making steering difficult. The best take-off procedure is to hold the tail down until sufficient speed is attained, and then raise the tail slowly.

11. ENGINE FAILURE DURING TAKE-OFF.

a. The chances of the engine failing during take-off can be reduced and prepared for by observing the following practices:

(1) Run up engine carefully and check thoroughly before take-off.

(2) Retract the landing gear as soon as the airplane is definitely airborne.

(3) Raise the flaps as soon as the airplane reaches a safe altitude.

b. If the engine fails immediately after the take-off, act quickly as follows:

(1) Depress the nose at once so that the airspeed does not drop below stalling speed.

(2) If external fuel tanks or bombs are installed, release them immediately.

(3) Release the canopy by pushing in and then raising either of the red release handles, one on each side of the forward end of the canopy.

WARNING

When releasing the canopy, drop seat and lower head as far as possible so as to avoid a head injury from the loosened canopy.

(4) Make sure landing gear has started to come up. There is no time to take further action, and even if it is only unlocked and on the way up, the gear will collapse on landing. Do not try to lower gear. There is less chance of personal injury if the airplane is landed with the gear up.

(5) Lower the flaps fully, if possible.

(6) Pull out idle cutoff control and turn "OFF" ignition switch.

(7) Turn fuel selector control "OFF."

(8) Turn battery switch "OFF."

(9) Land straight ahead, changing direction only to avoid obstructions.

(10) After landing, get out of the airplane as quickly as possible and remain outside.

12. CLIMB.

a. As soon as the airplane is sufficiently clear of the ground, proceed as follows:

(1) Retract the landing gear by pulling the landing gear control handle inboard and up. The handle is located on the control pedestal to the left and just forward of the seat. Wait 5 seconds after landing gear "UNSAFE" light goes out. Then move control handle back to neutral; the fairing door light should go out.

(2) Raise the flaps by moving flap control handle to the full up position when sufficient airspeed is attained and all obstacles are cleared.

(3) Check the coolant and oil temperatures, and the oil pressure.

13. DURING FLIGHT.

a. GENERAL.

(1) If combat tanks are installed, switch fuel selector control to either "L.H." or "R.H." and use fuel from each tank alternately until supply is exhausted; then switch selector control to "MAIN."

(2) Periodically check for these desired instrument readings:

Oil pressure 60-70 lbs./sq.in. (55 lbs./sq.in. minimum)

Auxiliary stage oil pressure 50-60 lbs./sq.in. (45 lbs./sq.in. minimum)

Oil temperature 70-85°C (Grade 1120), 60-70°C (Grade 1100) (105°C maximum Grade 1120, 90°C maximum Grade 1100)

Coolant temperature 105-121°C (125°C maximum)

War emergency 135°C maximum

Fuel pressure 23 lbs./sq.in. (27 lbs./sq.in. maximum)

Note

With the radiator air control set in the "AUTOMATIC" position, the coolant temperatures will be approximately 105-121°C and the oil temperatures will be approximately 70-85°C (Grade 1120) or 60-70°C (Grade 1100). It should be noted that with very high powers on hot days, even though the radiator air control is in the "AUTOMATIC" position, these temperature limits may be exceeded because the exit flap is in the full open position, making it impossible for the automatic control to maintain the desired temperature limits listed in paragraph (2) preceding.

14. FLIGHT OPERATION.

Refer to Specific Engine Flight Chart, section III, for engine operation.

15. GENERAL FLYING CHARACTERISTICS.

The effect of flap and landing gear operation on the trim of the airplane in flight is as follows:

- Landing gear retracted - airplane becomes tail heavy.
- Landing gear extended - airplane becomes nose heavy.
- Flaps lowered - airplane becomes nose heavy.
- Flaps raised - airplane becomes tail heavy.

16. ENGINE FAILURE DURING FLIGHT.

a. If the engine fails during flight, the airplane may be abandoned or brought in for a dead-stick landing, as the case requires. For a landing with the engine dead, follow these instructions:

(1) Depress the nose at once so that airspeed does not drop below stalling speed.

(2) If external fuel tanks or bombs are installed, release them immediately by pulling emergency bomb release handle at base of hydraulic control pedestal.

(3) Release the canopy by pushing in and raising either of the red release handles, one on each side of the forward end of the canopy.

WARNING

Drop seat and lower head as far as possible when pulling release handle so as to avoid injury from the loosened canopy. If the canopy does not fly off, open it slightly.

(4) When a reasonable doubt exists in the mind of the pilot as to the condition of the terrain on which he is being forced to land, or if there is a probability of the airplane nosing over or overrunning the available landing area, the landing gear should be retracted.

(5) Lower the flaps fully if possible.

(6) Move idle cutoff control to "OUT STOP" and turn ignition switch "OFF."

(7) Turn "OFF" fuel selector control and battery-starter switch.

(8) Land into the wind, changing direction only to avoid obstructions.

(9) After landing, get out of the airplane as quickly as possible and remain outside.

17. STALLS.

The stall in this airplane is comparatively mild. The airplane does not whip at the stall but rolls rather slowly and has very little tendency to drop into a spin. If the stick and rudder are released at the stall, the nose drops sharply and the airplane recovers almost instantly. When the stalling speed is reached, a wing will drop. In a straight power-off stall, some warning is given about 3 to 4 mph above the stall by slight elevator buffet. A high-speed stall is preceded by sharp buffeting at the elevators and wing root, but recovery is almost immediate when pressure on the stick is released. Recovery from any stall in this airplane is entirely normal, that is, by the release of back pressure on the stick and the application of rudder opposite the dropping wing.

18. ACROBATICS.

Inverted flying must be limited to 10 seconds because of loss of oil pressure and failure of the scavenge pump to operate in inverted position.

19. DIVING.

The maximum permissible diving speed is 475 IAS, during which the engine speed must not exceed 3300 rpm. It is of utmost importance to make allowance of ample altitude for a safe recovery before starting the dive.

20. NIGHT FLYING.

a. In flying this airplane at night, the sequence outlined for daylight operation should be even more strictly observed. In addition, the pilot should familiarize himself with the location of the various lights and their control switches.

(1) INSTRUMENT LIGHTING. - Turn on the fluorescent lamp on right side of cockpit by turning the rheostat knob (on left switch panel) to "START" until the lights come on; then switch to either "ON" or "DIM" positions. Rotating the lens housing selects the visible or invisible illumination.

(2) POSITION LIGHTS. - The position light switches are on the right switch panel. Two intensities of light are available: "BRIGHT" and "DIM."

(3) LANDING LIGHT. - The switch for extending and turning "ON" the landing light is located on the left switch panel.

(4) COCKPIT LIGHT. - A cockpit light is on the left side of the cockpit. Turn on light by turning switch on lamp housing.

(5) RECOGNITION LIGHTS. - Set the switches, located on the right switch panel, for the light or combination of lights desired. Place the switches in "STEADY" position for continuous operation and in "KEY" position for intermittent operation, by means of the keying switch on the right longeron.

IMPORTANT

Become accustomed to the position of the various light switches by feel, especially the switch for the landing light.

Note

Spare bulbs are contained on the forward side of the frame beside the rudder pedal on right side of the cockpit.

21. EMERGENCY EXIT.

a. In the event that an emergency exit must be made during flight, the following procedure is recommended.

(1) Release sliding canopy.

WARNING

When releasing canopy, drop seat and lower head as far as possible to avoid head injury when canopy releases.

(2) Raise seat to topmost position.

(3) If possible, reduce speed and trim airplane to fly "hands off."

(4) Disconnect headphones and oxygen tube.

IMPORTANT

Before jumping at a high altitude, inhale as much oxygen as possible.

- (5) Unfasten safety belt and shoulder harness.
- (6) Rise to a crouched position in seat, placing left foot on seat and right foot against right longeron. Grasp left longeron with left hand and left side of windshield with right hand.
- (7) Kick with legs and push with hands at instant of leaving cockpit, and dive headfirst for the star on the left wing.

Note

Using this method, the wing will either pass the body before contact or it will be possible to slide off the wing, thus eliminating the possibility of being stuck by the empennage.

22. APPROACH AND LANDING.

a. APPROACH. - When the airplane approaches the field, this sequence of operations should be followed:

- (1) Radiator air control "AUTOMATIC."
- (2) Fuel selector control to "MAIN." Booster pump switch on.
- (3) Propeller control set for 2800 rpm.
- (4) Lower the landing gear below 170 IAS. Wait at least 10 seconds after gear "SAFE" light comes on before returning control to neutral. Check position of gear by indicator lights on left switch panel. The fairing doors and landing gear "UNSAFE" indicator lights should be off and the landing gear "SAFE" light should be on.

CAUTION

After landing gear control has been placed in the "DOWN" position, do not attempt to retract gear until it is down and locked.

- (5) If desired, the flaps may be lowered 15 degrees to give a steeper approach angle. When the airplane has been brought into the wind for landing, the flaps should be lowered fully at an altitude of at least 400 feet, provided the indicated airspeed is below 160 IAS and above 100 IAS.

b. LANDING. - Having turned into the field and lowered the flaps, maintain a gliding speed of 130 IAS. Adjust the elevator trim tabs to assist in landing. Having stopped after landing, raise the flaps before taxiing.

c. CROSS-WIND LANDING. - As this airplane has a wide tread landing gear and a locked tail wheel, cross-wind landings may be negotiated safely. Keep one wing down and into the wind, to counteract drift.

d. EMERGENCY OPERATION OF LANDING GEAR. - In the event of hydraulic system failure, lower the landing gear by placing landing gear control handle in the "DOWN" position, with airspeed below 140 IAS. If gear does not lock because of air pressure against fairings, yaw airplane until landing gear indicator light indicates "SAFE."

Note

It is necessary that the airspeed be below 140 IAS during emergency operation of the landing gear, since air loads will hold the fairing doors closed above 140 IAS. After gear is lowered, the fairing doors will remain down.

e. TAKE-OFF IF LANDING IS NOT COMPLETED. - In the event of an unsuccessful attempt to land, open the throttle and move propeller control to full "INCREASE RPM." Raise the landing gear immediately; then, when the airspeed has reached 100 IAS, raise the flaps slowly.

23. STOPPING ENGINE.

Note

Before stopping engine, move canopy control handle to "OPEN." When canopy is open, pull out on control handle and move it to the "UNLOCK" position.

a. Stop engine as follows:

- (1) Turn booster pump switch "OFF."
- (2) Use oil dilution as required.
- (3) Run engine to 1500 rpm, pull out idle cutoff control, and slowly move throttle fully open. Leave idle cutoff control out as a precaution against accidental starting.
- (4) Turn ignition switch to "OFF" after the engine stops turning.
- (5) Turn fuel selector control "OFF."

24. BEFORE LEAVING COCKPIT.

a. After engine stops, proceed as follows:

- (1) Turn "OFF" all switches.
- (2) Set parking brakes.
- (3) Have ground personnel bring surface control lock, and install it.
- (4) Place carburetor air control in "FILTERED" position.
- (5) Slide canopy shut after leaving cockpit.

POWER PLANT CHART																	
AIRCRAFT MODEL(S) P-51J			PROPELLER(S) AEROPRODUCTS CONSTANT-SPEED			ENGINE MODEL(S) V-1710-110											
Grade 1120			Grade 1100														
GAGE READING	FUEL PRESS.	OIL PRESS.	OIL TEMP.	COOLANT TEMP.	OIL TEMP.	OIL ⁽¹⁾ CONS.	MAXIMUM PERMISSIBLE DIVING RPN: 3200 MINIMUM RECOMMENDED CRUISE RPN: 2200 MAXIMUM RECOMMENDED TURBO RPN:										
DESIRED MAXIMUM	23 27	60-70 85	70-85 105	105-121 125*	60-70 90	14.5	OIL GRADE: (S) 1120 (V) 1100 FUEL GRADE: 130 SPEC. NO. AN-F-23 AMEND. 2										
MINIMUM IDLING		55 15															
WAR EMERGENCY (COMBAT EMERGENCY)		MILITARY POWER (NON-COMBAT EMERGENCY)			OPERATING CONDITION			NORMAL RATED (MAXIMUM CONTINUOUS)		MAXIMUM CRUISE (NORMAL OPERATION)							
5 MINUTES		15 MINUTES			TIME LIMIT MAX. CYL. NO. TEMP.			UNLIMITED		UNLIMITED							
RUN 3200		RUN 3200			MIXTURE* R. P. M.			RUN 2700		RUN 2300							
MANIF. PRESS.	SUPER- CHARGER	FUEL ⁽²⁾ Gal./Min	MANIF. PRESS.	SUPER- CHARGER	FUEL ⁽²⁾ Gal./Min	STD. TEMP. °C	PRESSURE ALTITUDE	STD. TEMP. °F	MANIF. PRESS.	SUPER- CHARGER	FUEL GPH ⁽³⁾	MANIF. PRESS.	SUPER- CHARGER	FUEL GPH ⁽³⁾			
DATA WITHHELD UNTIL FINAL SETTING OF FUEL METERING PUMP IS ESTABLISHED.			36.0		1.8	-55.0 -55.0 -55.0	40,000 FT. 38,000 FT. 36,000 FT.	-67.0 -67.0 -67.0									
			40.5 45.0 50.3	AUTOMATICALLY CONTROLLED	2.0 2.3 4.5	-52.4 -48.4 -44.4	34,000 FT. 32,000 FT. 30,000 FT.	-42.3 -55.1 -48.0	31.0	AUTOMATICALLY CONTROLLED	74	AUTOMATICALLY CONTROLLED					
			50.7 51.7 52.1		2.5 2.5 2.5	-40.5 -36.5 -32.5	28,000 FT. 26,000 FT. 24,000 FT.	-40.9 -33.7 -26.5	34.0 37.0 39.5				85 94 100				
			52.4 52.6 52.9		2.5 2.5 2.6	-28.6 -24.6 -20.7	22,000 FT. 20,000 FT. 18,000 FT.	-19.4 -12.3 -5.2	42.0 43.5 43.5				107 109 109	37.0 37.0		81 80	
			53.0 53.3 53.9		2.6 2.6 2.6	-16.7 -12.7 -8.8	16,000 FT. 14,000 FT. 12,000 FT.	2.0 9.1 16.2	43.6 43.8 44.0				109 109 109	37.0 37.0 37.1		80 79 79	
			54.3 54.6 55.4		2.6 2.6 2.6	-4.8 -0.8 3.1	10,000 FT. 8,000 FT. 6,000 FT.	22.4 30.5 37.6	44.1 44.3 44.4				109 109 109	37.1 37.2 37.3		78 78 78	
			55.9 56.6 57.4		2.6 2.7 2.7	7.1 11.0 15.0	4,000 FT. 2,000 FT. SEA LEVEL	44.7 51.8 59.0	44.7 45.0 45.4				109 109 110	37.5 37.7 38.0		77 77 77	

GENERAL NOTES

(1) OIL CONSUMPTION: MAXIMUM U.S. QUART PER HOUR PER ENGINE.

(2) Gal./Min: APPROXIMATE U.S. GALLON PER MINUTE PER ENGINE

(3) GPH: APPROXIMATE U.S. GALLON PER HOUR PER ENGINE.

F.T.: MEANS FULL THROTTLE OPERATION.

VALUES SHOWN ARE FOR STANDARD NACA CONDITIONS WITHOUT RAM.

FOR COMPLETE CRUISING DATA SEE APPENDIX II

NOTE: TO DETERMINE CONSUMPTION IN BRITISH IMPERIAL UNITS, MULTIPLY BY 10 THEN DIVIDE BY 12. RED FIGURES ARE PRELIMINARY SUBJECT TO REVISION AFTER FLIGHT CHECK.

TAKE-OFF CONDITIONS: 3200 RPM - 59.4° BP - 5 MIN FUEL FLOW 2.8 GAL./MIN.

CONDITIONS TO AVOID:

SPECIAL NOTES

*135°C MAXIMUM COOLANT TEMPERATURE AT WAR EMERGENCY.

**SINGLE SETTING MIXTURE CONTROL - SPEED DENSITY CARBURETOR.

DATA AS OF 2/14/45 BASED ON ESTIMATED PERFORMANCE

AMP-524
8-1-48

Figure 19A—Power Plant Chart
CONFIDENTIAL

Section IV
COMMUNICATION EQUIPMENT1. GENERAL.

The communication equipment consists of an SCR-522-A command set, a Detrola Model 438 receiver, and SCR-695-A identification equipment. The command and identification sets are located in the radio compartment aft of the pilot's seat. The Detrola Model 438 receiver may be installed on the floor beside the control stick for use during ferrying operations.

2. COMMAND SET, SCR-522-A.

a. DESCRIPTION. - This set is a push-button type of transmitter-receiver, operating on the 100 to 156 mc band. The control box is on the right side of the cockpit, and a transmit-receive remote control button is located on the throttle lever. The remote control switch on the aft end of the control box is wired in the "REM" position and will necessitate the use of the remote control button on the throttle lever for both transmission and reception. Lights adjacent to the band selection buttons on the control box indicate which of the four voice modulated bands is being used. A remote contactor, at the forward right side of the cockpit, switches the transmitter from any of the four bands to the tone modulated D band for 14 seconds of every minute. The pointer on the face of the contactor indicates when the switching action will take place. The clock switch on the contactor should never be touched in flight; it is set on the ground by the service crew. The Detrola auxiliary receiver is installed with this equipment for use in the reception of beacon signals, weather broadcasts, and airport communications.

b. OPERATION.

(1) TRANSMISSION.

(a) Push button "A," "B," "C," or "D," depending on the band to be used.

(b) Allow the set approximately one minute to warm up. During this warm-up period, check the contactor operation with the contactor switch in the "OUT" and "IN" positions.

(c) To transmit, press the remote control button on the throttle lever.

(d) To turn the set off, press the button on the control box marked "OFF."

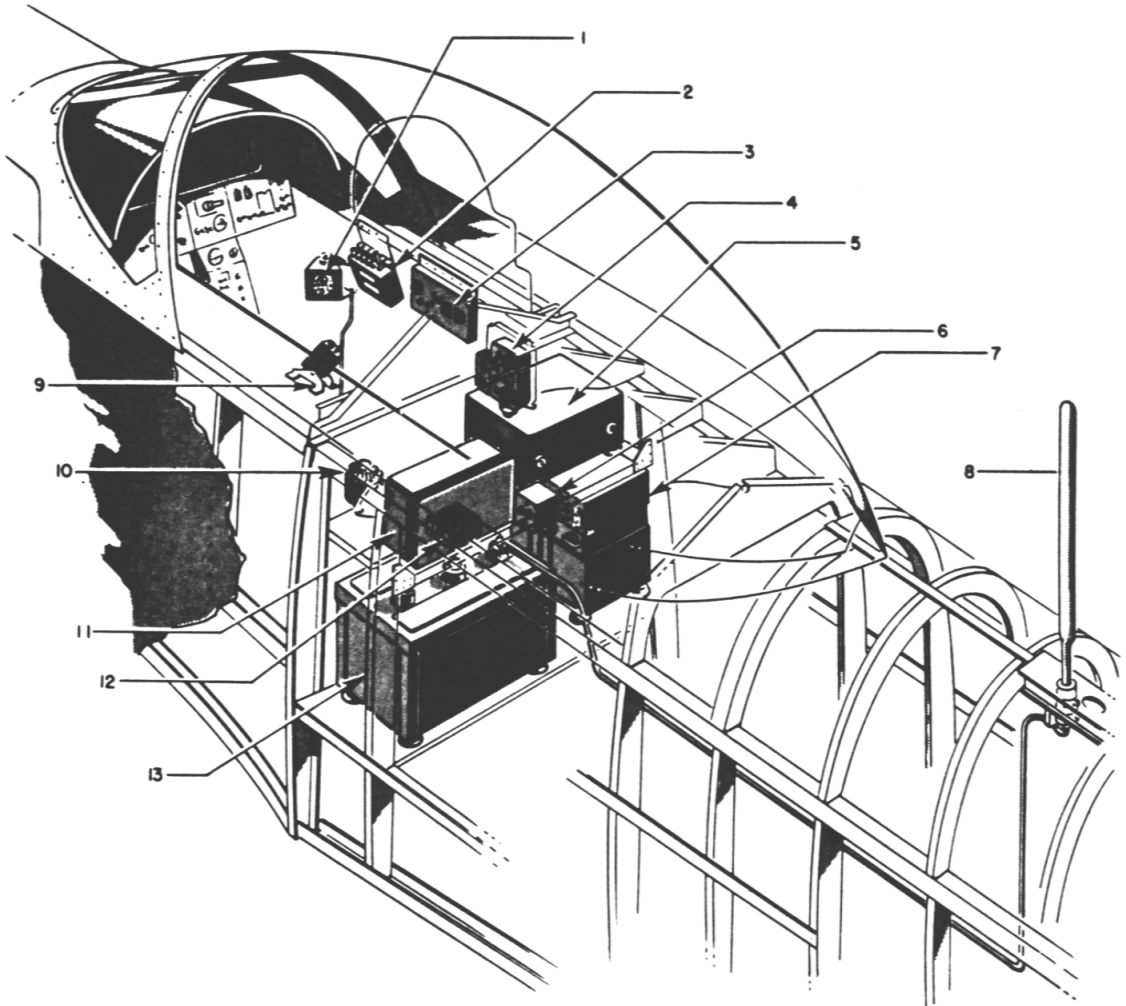

- | | |
|------------------------------|----------------------------------|
| 1. REMOTE CONTACTOR | 8. SCR-522 ANTENNA MAST |
| 2. SCR-522 CONTROL BOX | 9. DETROLA RECEIVER MODEL 438 |
| 3. SCR-695 DETONATOR BUTTONS | 10. SCR-695 INERTIA SWITCH |
| 4. SCR-695 CONTROL BOX | 11. RADIO JUNCTION BOX |
| 5. SCR-522 DYNAMOTOR | 12. MC-299 ADAPTER |
| 6. SCR-695 INDICATOR LIGHT | 13. SCR-522 TRANSMITTER-RECEIVER |
| 7. SCR-695 RADIO | |

100-71-70A

Figure 20—Communication Equipment

Note

A lever is located at the forward end of the control box to regulate the brightness of the band indicator lights.

(2) RECEPTION.

(a) Push button "A," "B," "C," or "D," depending on which band is desired and allow the set approximately one minute to warm up. Reception of any signal will indicate that the receiver is operating properly.

(b) To receive, leave the remote control button on the throttle lever in its normal extended position.

(c) To turn the set off, press the button on the control box marked "OFF."

Note

The Detrola auxiliary receiver used with this set is turned on and off by the hexagonal control knob. The round knob is the frequency control.

3. IDENTIFICATION EQUIPMENT.

The identification equipment is controlled from a box on the right side of the cockpit. For operating instructions, see the communications officer in charge. Detonator buttons and an inertia crash switch are provided with this equipment.

WARNING

Insert the destructor plug only when the airplane is ready to take off. Remove the plug immediately after landing.

4. PYROTECHNIC SIGNAL PISTOL.

a. DESCRIPTION. - A pyrotechnic pistol and cartridges are stowed at the forward left side of the cockpit. A pistol mount is located on the left side of the cockpit, aft of the pilot's seat. A cap, chained to the mount, covers the port when the pistol is not installed.

b. OPERATION.

(1) Remove the cover cap from the mount.

(2) Insert the muzzle of the pistol into the mount so the lugs on the pistol barrel slip into the mount slots.

(3) Press the mount release trigger and turn the pistol, to the right or left, as far as possible.

(4) To load the pistol, press the breech lock lever, behind the mount release trigger, and apply force on the pistol butt until the breech opens. Insert the signal cartridge into the chamber and close the breech. The pistol is automatically cocked when the breech is closed.

WARNING

Do not attempt to load the pistol when it is not in the mount.

Section V
ARMAMENT1. GUNNERY EQUIPMENT.

a. DESCRIPTION. - Two fixed .50-caliber M-2 machine guns, capable of firing 250 rounds of ammunition each and equipped with electric heaters, are mounted in each wing. The guns are aligned to converge the line of fire and the line of sight at a range of 300 yards. They are manually charged prior to take-off and are operated simultaneously by a trigger-type switch on the control stick. An optical gun sight is provided and a gun sight aiming point camera is mounted in the leading edge of the left wing.

b. OPERATION.

(1) Turn the gun and camera safety switch, located on the left switch panel, to "GUNS AND CAMERA."

(2) Use the gun heaters as necessary. The heater switch is located on the left switch panel.

(3) To sight the guns, turn the gun sight filament switch to "MAIN" and the gun sight rheostat, located on the left switch panel, to "BRIGHT." Turning the rheostat in a clockwise direction increases the light intensity of the image.

Note

If the main gun sight filament fails, turn the switch to "ALTERNATE."

(4) Fire the guns by squeezing the trigger-type switch on the control stick grip. To operate the gun camera only, turn the gun safety switch to "CAMERA" and squeeze the trigger-type switch.

Note

At low temperatures, the heaters in the camera will function automatically. Therefore, keep the gun and camera safety switch in the "OFF" position except when the camera or guns are to be used.

(5) Before landing, make certain that the gun and camera safety switch, and the gun heater switch are on "OFF."

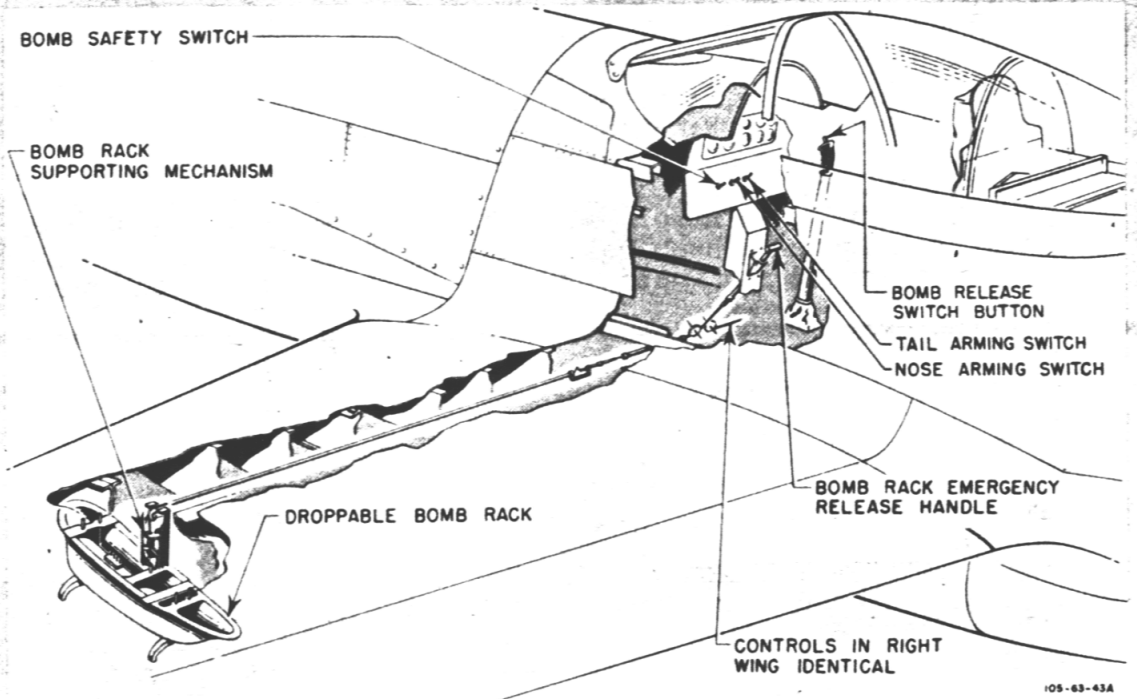

Figure 21—Bomb System

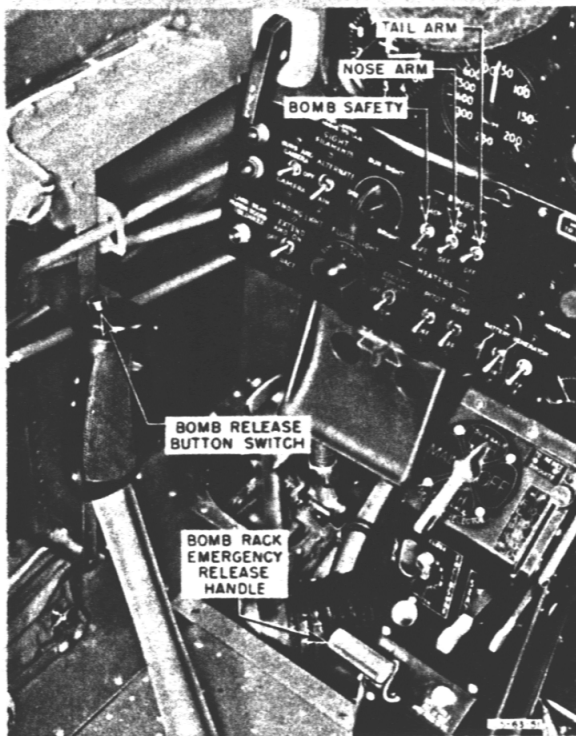

Figure 22—Bomb Controls

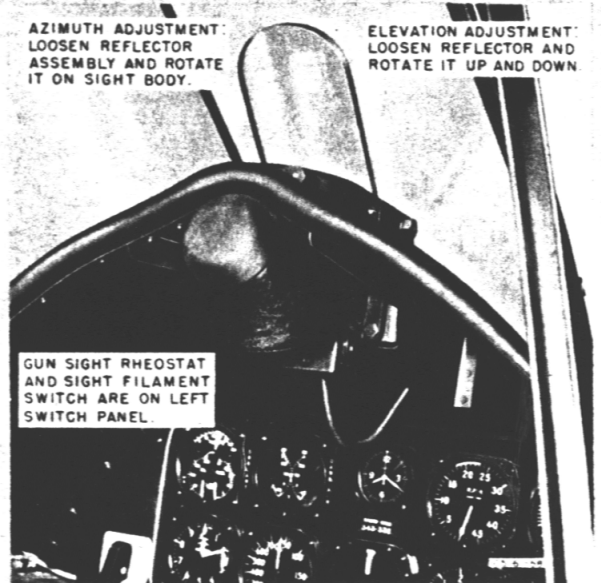

Figure 23—Gun Sight

2. BOMBING EQUIPMENT.

a. DESCRIPTION. - An external droppable bomb rack may be installed under each wing to carry a 100, 250, 300, or 500-pound bomb. Depth charges, chemical tanks, or droppable 75-gallon combat fuel tanks may also be carried on the racks when bombs are not installed. The emergency bomb release handle is mounted at the base of the control pedestal. The bomb control electrical system consists of a bomb release switch on top of the control stick, and safety and fusing switches on the left switch panel.

b. OPERATION.

(1) NORMAL RELEASE. - Turn the bomb switch on the left switch panel to "READY" and fusing switches to "NOSE ARM" and/or "TAIL ARM" as desired; then press the release switch on top of the control stick. When bombs have been released, turn the switches "OFF."

(2) EMERGENCY RELEASE. - Unlatch the guard from the emergency bomb release handle at the base of the control pedestal; then pull the handle. This action jettisons both the racks and the bombs. Bombs released in this manner are in a safe condition.

Section VI
OXYGEN EQUIPMENT1. DESCRIPTION.

Two Type D-2 low-pressure cylinders supply a normal full pressure of 400 pounds per square inch to the system. Two additional cylinders may also be installed. A blinker flow indicator at the right of the instrument panel operates with the breathing of the consumer. An oxygen regulator is on the right side of the cockpit. If pressure in the oxygen cylinders drops below the danger point (100 pounds per square inch), a signal light, located above the flow indicator, will illuminate. Type A-9, A-9A, A-10, or A-14 masks may be used with this equipment. The cylinders may be refilled, without removing the cylinders from the airplane, through a filler valve inside the radio compartment. See figure 24 for the oxygen consumption chart and location of the filler valve.

2. OPERATION.a. PREFLIGHT CHECK.

(1) See that the mask fits properly, and check for leaks by holding the thumb over the corrugated hose fitting and inhaling normally. If a leakage greater than 5 percent is apparent, flights over 30,000 feet must not be made. See that the mask is free of all foreign material.

(2) Check to see that the gasket at the end of the regulator tubing is in place and insert the mask attachment fitting. This connection must be tight, requiring a force of at least 10 pounds to separate.

(3) Inspect the mask-regulator tubing for damage. Make sure all tubing clamps are firmly attached.

(4) Attach the spring clip on the tubing high up on the chest to the clothing or parachute harness to permit free movement of the head without kinking the mask hose.

(5) Make certain the knurled collar at the outlet end of the regulator is tight. Examine the top of the diaphragm to see that it is not ruptured or distorted.

(6) Turn the red emergency knob on the regulator "ON," testing the oxygen flow. Check the pressure gage to see that there is no perceptible pressure drop. Turn the emergency knob "OFF" and make sure there is no leakage. Leave the knob in this position.

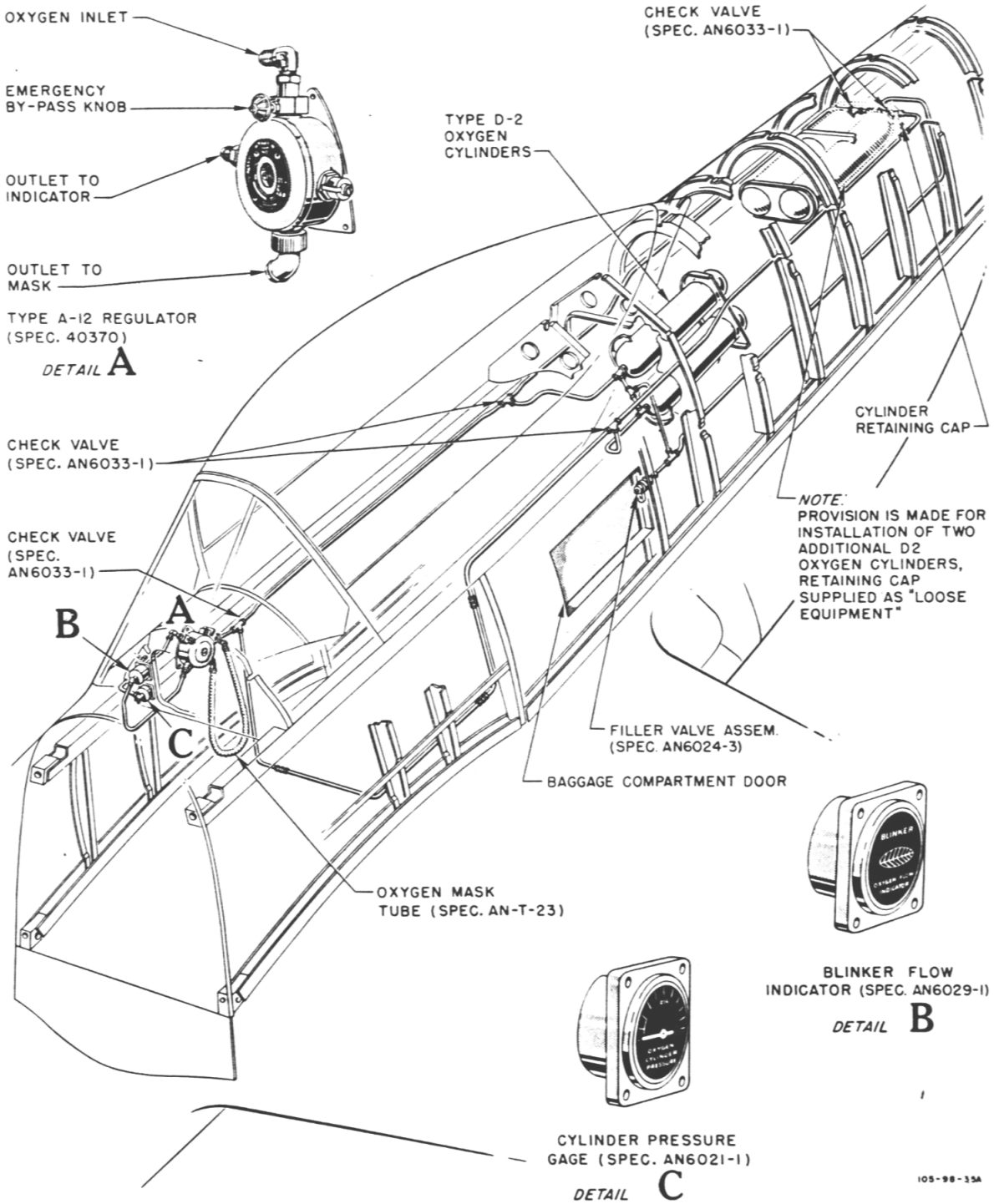

Figure 24—Oxygen System

(7) Turn the auto-mix control on the regulator "OFF." Note on the flow indicator that, during inhalation, the top diaphragm drops and that nearly 100 percent oxygen is being received. Turn the auto-mix control "ON"; notice that little, or no, oxygen flow is indicated. Leave the control in this position.

(3) Before taking off, make certain the pressure gage shows a sufficient oxygen supply for the mission.

(9) Use of oxygen should be started immediately prior to take-off on all night flights.

b. DURING FLIGHT.

(1) Use oxygen above 10,000 feet during all day flights.

(2) Turn the red emergency knob on the regulator "ON" if an insufficient amount of oxygen consumption is felt.

(3) Check the pressure gage and the flow indicator frequently.

(4) Do not permit the mask regulator tubing to kink or twist.

(5) Remove ice forming on the mask by manipulating the mask at frequent intervals.

(6) During all flights over 30,000 feet, pay particular attention to the oxygen system. Be sure all units and instruments are functioning perfectly.

c. AFTER FLIGHT.

(1) If any difficulties have developed in the equipment or system during flight, take the necessary steps to have them corrected.

(2) If the oxygen pressure is below 100 pounds per square inch, check to see that the supply warning light is illuminated. If the pressure is slightly above 100 pounds per square inch after completion of a mission, bleed oxygen from the system by turning the red emergency knob "ON" until the supply warning light illuminates at approximately 100 pounds per square inch. Turn the emergency knob "OFF."

(3) Wash the mask with water and a mild soap; dry thoroughly, and leave in a clean, airy place out of the sunlight.

Note

See that the mask is properly stored or hung in the airplane when not in use. Do not subject the mask to sunlight, as this will cause rapid deterioration.

Section VII
HEATING, VENTILATING, AND DEFROSTING SYSTEM1. DESCRIPTION.

A combustion-type heater, operated by a switch on the left switch panel, heats the cockpit interior and defrosts the windshield. Air is supplied to the system through ducts in the lower engine cowl. Distribution of heated air to the defroster outlets at the windshield panels and to an outlet near the pilot's feet, is controlled by a valve on the control pedestal below the center switch panel. A pressure switch, sensitive to ventilating air pressure, automatically prevents heater operation when the airflow is less than the required minimum. A thermostatically controlled switch prevents operation of the heater above the maximum permissible air temperature. When the heater is not operating, the system may be used to ventilate the cockpit.

2. OPERATION.

a. Start the heater by moving the heater switch on the left switch panel to "HIGH AND START."

b. Select the desired amount of cockpit heat and defroster heat by regulating the valve on the control pedestal. Never close the valve completely when the heater is operating.

c. Turn the heater switch to "LOW" if desired.

d. Stop the heater by turning "OFF" the switch.

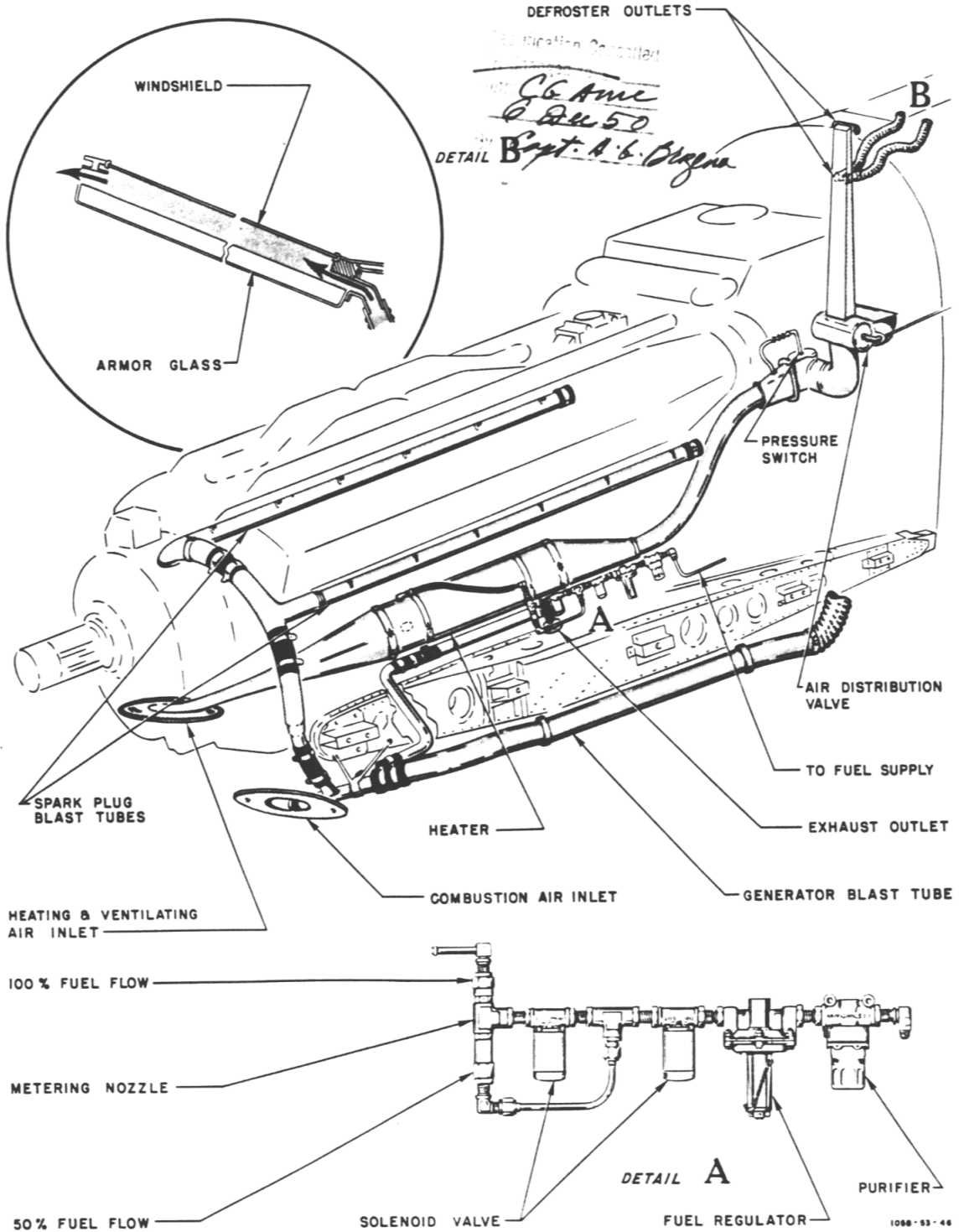

Figure 25—Heating, Ventilating, and Defrosting System

