

AIR PUBLICATION **1565 E**
AND
AIR PUBLICATION **2280 A, B & C**

Pilot's Notes

PILOT'S NOTES

SPITFIRE VA, VB AND VC AIRCRAFT

MERLIN 45, 45M, 46, 50, 50A, 50M, 55 OR 55M ENGINE

AND

SEAFIRE IB, IIC AND III AIRCRAFT

MERLIN 45, 46 (EXCEPT MK.III), 50 OR 55 ENGINE

Prepared by direction of the
Minister of Aircraft Production



Promulgated by order of the Air Council

AIR MINISTRY



"CROWN COPYRIGHT. REPRODUCED BY PERMISSION OF HER MAJESTY'S STATIONERY OFFICE."

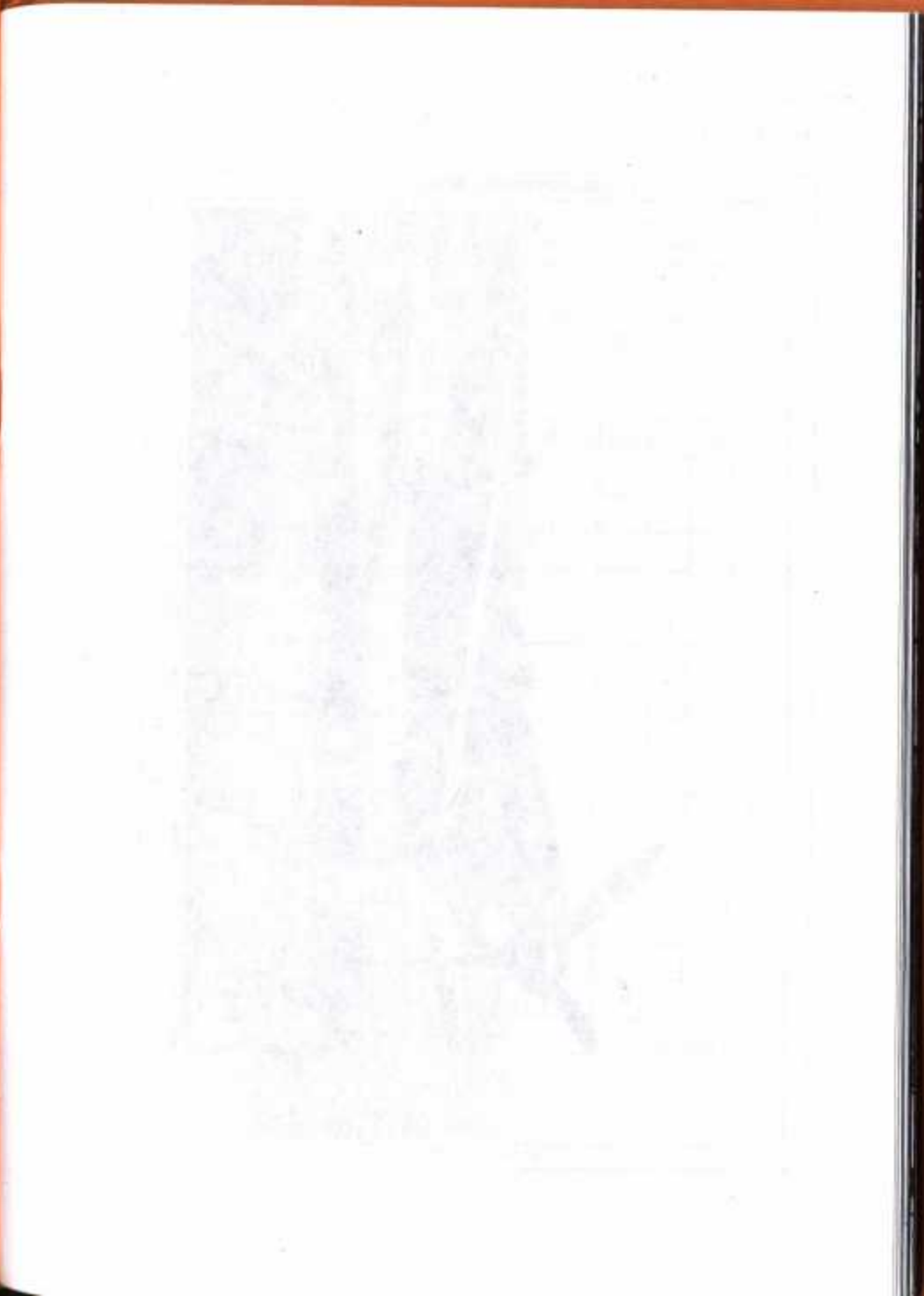
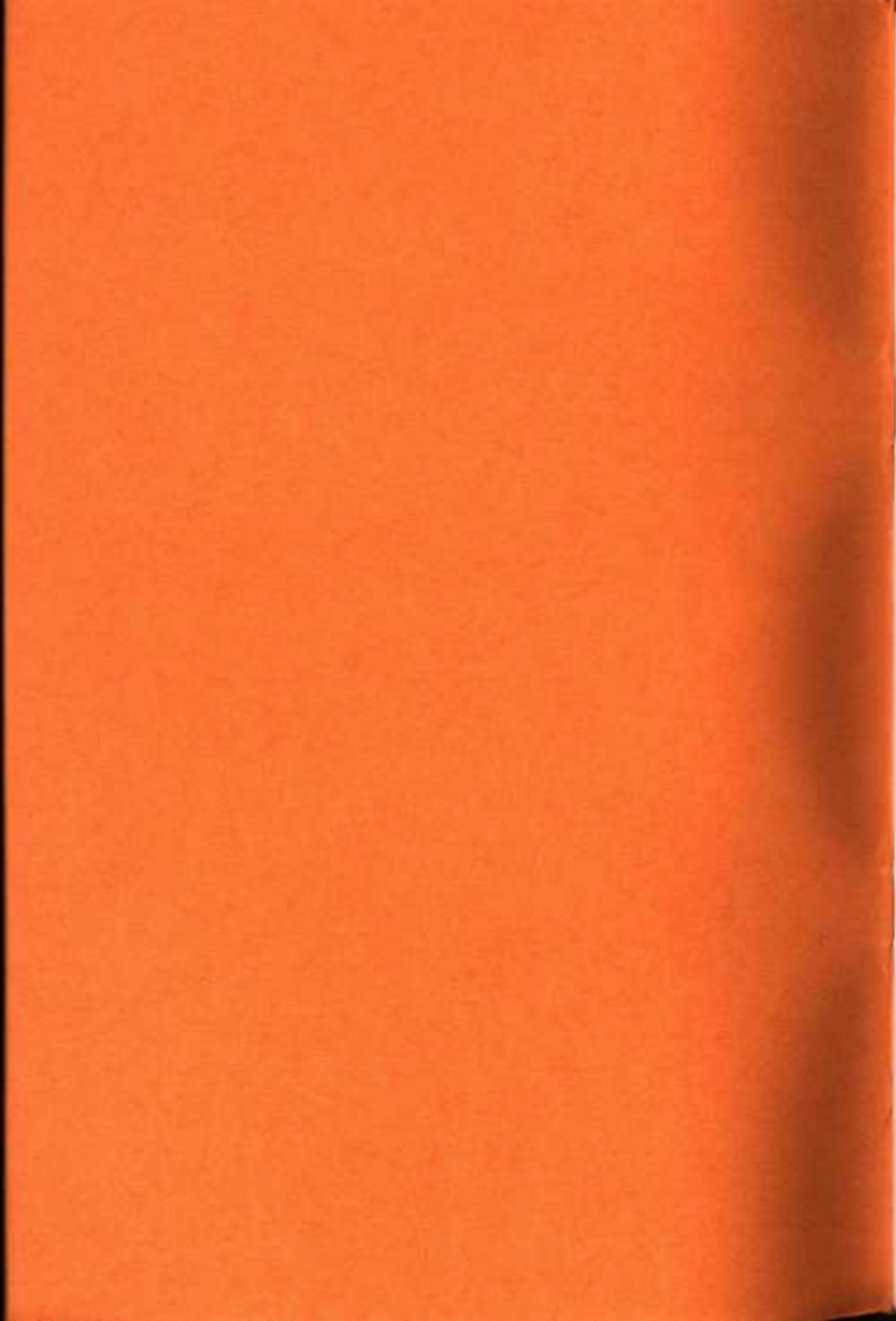

AP 1565E, VOL. I, & PN.

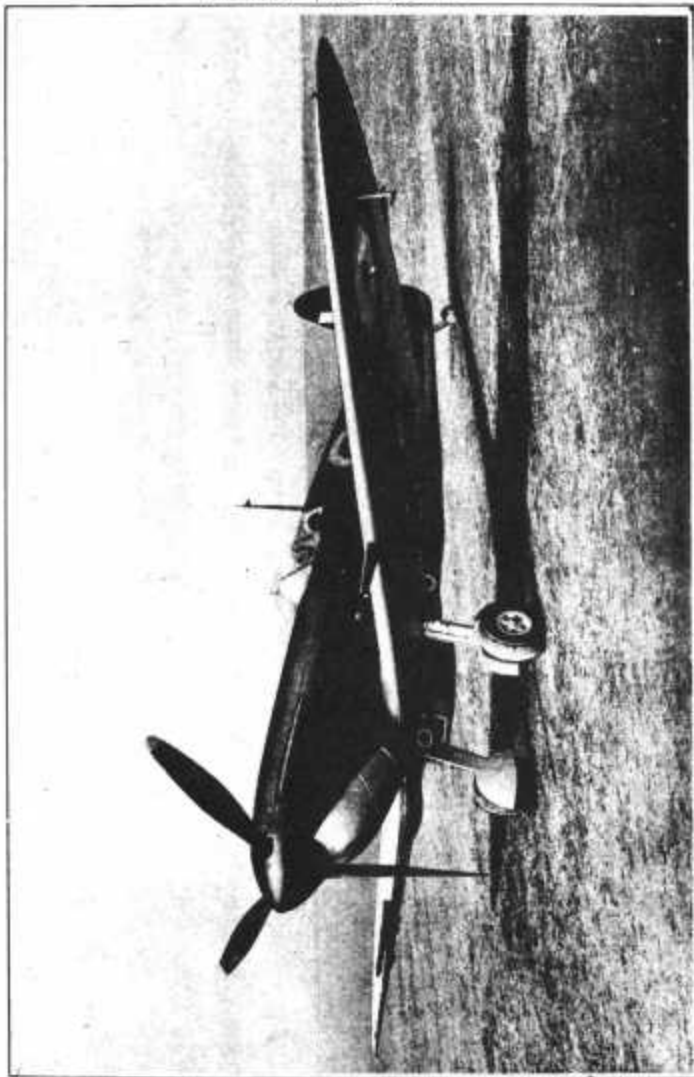

FRONTISPIECE

THE SPITFIRE VB AEROPLANE

AMENDMENT CERTIFICATE

Incorporation of an amendment list in this publication should be certified by inserting the amendment list number, initialling in the appropriate column and inserting the date of incorporation.

Holders of the Pilot's Notes will receive only those amendment lists applicable to the preliminary matter, introduction and sections 1 and 2.

Amendt. List No.	1	2	4	7/D	11/E	16/F	19/G	20/H	28	39
Prelim. matter			✓					✓		✓
Leading Partics.										
Introducn.										
Section 1			✓	✓		✓	✓	✓		
Section 2	✓	✓	✓	✓	✓		✓	✓	✓	✓
Section 3										
Section 4										
Section 5										
Section 6										
Section 7										
Section 8										
Section 9										
Section 10										
Section 11										
Section 12										
Date of incorpn.	Incorporated February 1943									FEB 1944

Amendt. List No.															
Prelimy. matter															
Leading Partics.															
Introduc.															
Section 1															
Section 2															
Section 3															
Section 4															
Section 5															
Section 6															
Section 7															
Section 8															
Section 9															
Section 10															
Section 11															
Section 12															
Date of incorp.															

NOTES TO OFFICIAL USERS

Air Ministry Orders and Vol. II leaflets as issued from time to time may affect the subject matter of this publication. It should be understood that amendment lists are not always issued to bring the publication into line with the orders or leaflets and it is for holders of this book to arrange the necessary link-up.

Where an order or leaflet contradicts any portion of this publication, an amendment list will generally be issued, but when this is not done, the order or leaflet must be taken as the overriding authority.

Where amendment action has taken place, the number of the amendment list concerned will be found at the top of each page affected, and amendments of technical importance will be indicated by a vertical line on the left-hand side of the text against the matter amended or added. Vertical lines relating to previous amendments to a page are not repeated. If complete revision of any division of the book (e.g. a Chapter) is made this will be indicated in the title page for that division and the vertical lines will not be employed.

AEROPLANE CONTROLS

7. (a) Primary flying controls and locking devices.- The control column is of the spade-grip pattern and incorporates the brake lever (13) and gun and cannon firing control (11). The rudder pedals (28) have two positions for the feet and are adjustable for leg reach by rotation of star wheels (82) on the sliding tubes. Control locking struts are stowed on the right hand side of the cockpit, behind the seat.
- (b) To lock the control column, the longer strut should be clamped to the control column handle at one end and the other end inserted in a key-hole slot in the right hand side of the seat. The fixed pin on the free end of the arm attached to this strut at the control column end should then be inserted in a lug (84) on the starboard datum longeron, thus forming a rigid triangle between the column, the seat and the longeron.
- (c) To lock the rudder pedals, a short bar with a pin at each end is attached to the other struts by a cable. The longer of the two pins should be inserted in a hole in the starboard star wheel bearing (82) and the shorter in an eyebolt (81) on the fuselage frame directly below the front of the seat. The controls should be locked with the seat in its highest position.
8. Flying instruments.- A standard blind flying instrument panel is incorporated in the main panel. The instruments comprise: airspeed indicator, altimeter, directional gyro, artificial horizon, rate of climb and descent indicator, and turn and bank indicator.
9. Trimming tabs.- The elevator trimming tabs are controlled by a hand wheel (52) on the left hand side of the cockpit, the indicator (3) being on the instrument panel. The rudder trimming tab is controlled by a small hand wheel (57) and is not provided with an indicator. The aeroplane tends to turn to starboard when the hand wheel is rotated clockwise.

10. Undercarriage control and indicators

- (a) The undercarriage selector lever (80) moves in a gated quadrant, on the right hand side of the cockpit. An automatic cut-out in the control moves the selector lever into the gate when it has been pushed or pulled to the full extent of the quadrant. A hydraulic valve indicator in the quadrant shows DOWN, or IDLE, or UP depending upon the position of the hydraulic valve. UP or DOWN should normally show only when the selector lever is operated to raise or lower the undercarriage, and IDLE when the lever has automatically sprung back into the gate after raising or lowering the undercarriage. If, with the engine not running, the indicator shows DOWN, it should return to IDLE when the engine is started.
- (b) To raise the undercarriage the lever is pushed forward, but it must first be pulled back and then across to disengage it from the gate. When the undercarriage is raised and locked, the lever will spring into the forward gate.
- (c) To lower the undercarriage the lever is pulled back, but it must first be pushed forward and then across to disengage it from the gate. When the undercarriage is lowered and locked, the lever will spring into the rear gate.
- (d) Electrical visual indicator.- The electrically operated visual indicator (5) has two semi-transparent windows on which the words UP on a red background and DOWN on a green background are lettered; the words are illuminated according to the position of the undercarriage. The switch (44) for the DOWN circuit of the indicator is mounted on the inboard side of the throttle quadrant and is moved to the ON position by means of a striker on the throttle lever; this switch should be returned to the OFF position by hand when the aeroplane is left standing for any length of time. The UP circuit is not controlled by this switch.
- (e) Mechanical position indicator.- A rod that extends through the top surface of the main plane is fitted to each undercarriage unit. When the wheels are down the rods protrude through the top of the main plane and when they are up the top of the rods, which are painted red, are flush with the main plane surfaces.

- (f) Warning horn.- The push switch (43) controlling the horn is mounted on the throttle quadrant and is operated by a striker on the throttle lever. The horn may be silenced, even though the wheels are retracted and the engine throttled back, by depressing the push button (48) on the side of the throttle quadrant. As soon as the throttle is again advanced beyond about one quarter of its travel the pushbutton is automatically released and the horn will sound again on its return.
11. Flap Control.- The split flaps have two positions only, up and fully down. They cannot therefore, be used to assist take-off. They are operated pneumatically and are controlled by a finger lever (7).
12. Undercarriage emergency operation.
- (a) A sealed high-pressure cylinder containing carbon-dioxide and connected to the undercarriage operating jacks is provided for use in the event of failure of the hydraulic system. The cylinder (70) is mounted on the right hand side of the cockpit and the seal can be punctured by means of a red painted lever (77) beside it. The handle is marked EMERGENCY ONLY and provision is made for fitting a thin copper wire seal as a check against inadvertent use.
- (b) If the hydraulic system fails, the pilot should ensure that the undercarriage selector lever is in the DOWN position (this is essential) and push the emergency lowering lever forward and downward. The angular travel of the emergency lever is about 100° for puncturing the seal of the cylinder and then releasing the piercing plunger; it must be pushed through this movement and allowed to swing downwards. NO attempt should be made to return it to its original position until the cylinder is being replaced.

13. Wheel brakes.- The control lever (13) for the pneumatic brakes is fitted on the control column spade grip; differential control of the brakes is provided by a relay valve connected to the rudder bar. A catch for retaining the brake lever in the on position for parking is fitted below the lever pivot. A triple pressure gauge (2), showing the air pressures in the pneumatic system cylinders and at each brake, is mounted on the left hand side of the instrument panel.

ENGINE CONTROLS

14. Throttle and mixture controls.- The throttle and mixture levers (33 and 42) are fitted in a quadrant on the port side of the cockpit. A gate is provided for the throttle lever in the take-off position and an interlocking device between the levers prevents the engine from being run on an unsuitable mixture. Friction adjusters (47) for the controls are fitted on the side of the quadrant. On later aircraft there is no mixture control or, if fitted, it is rendered inoperative.
15. Automatic boost cut-out.- The automatic boost control may be cut out by pushing forward the small red painted lever (1) at the forward end of the throttle quadrant.
16. Airscrew controls.- The control levers (50) for the de Havilland 20° or Rotol 35° constant speed airscrew is on the throttle quadrant. The de Havilland 20° airscrew has a Positive Coarse Pitch position which is obtained in the extreme aft position of the control lever, when the airscrew blades are held at their maximum coarse pitch angles and the airscrew functions as a fixed airscrew. Some aircraft are fitted with a De Havilland hydromatic propeller.
17. Radiator flap control.- The flap at the outlet end of the radiator duct is operated by a lever (31) and ratchet on the left hand side of the cockpit. To open the flap, the lever should be pushed forward after releasing the ratchet by depressing the knob at the top of the lever. The normal minimum drag position of the flap lever for level flight is shown by a red triangle on the top of the map case fitted beside the lever. A notch beyond the normal

- position in the aft direction provides a position of the lever when the warm air is diverted through ducts into the main planes for heating the guns at high altitude.
18. Slow-running cut-out.- The control on the carburettor is operated by pulling the ring (22) on the right-hand side of the instrument panel.
19. Fuel cock controls and contents gauges.- The fuel cock controls (25), one for each tank, are fitted at the bottom of the instrument panel. With the levers in the up position the cocks are open. Either tank can be isolated, if necessary. The fuel contents gauge (20) on the instrument panel indicates the contents of the lower tank, but only when the adjacent push button is pressed. On later aircraft there is only one fuel cock control. For jettisonable tank cock control and jettison lever see Addendum.
20. Immersed fuel pump.- An immersed fuel pump is fitted in the lower fuel tank for use at heights over 25,000 ft., when the fuel pressure falls. The pump is electrically operated and the switch controlling it is mounted on the left hand side of the cockpit, adjacent to the seat.
21. Fuel priming pump.- A hand-operated pump (23) for priming the engine is mounted below the right hand side of the instrument panel.
22. Ignition switches.- The ignition switches (83) are on the left hand bottom corner of the instrument panel.
23. Electric starting.- On early aeroplanes the starting magneto switch (80) is at the right-hand bottom corner of the instrument panel and the engine starting pushbutton (24) is under a shield above the fuel cock controls. On later aeroplanes the starting magneto switch is not provided but a booster coil push switch is fitted adjacent to the starter pushbutton. Current for the starter motor is normally supplied by an external battery, which is connected to the socket on the engine mounting U - frame, accessible through a door in the engine cowling panel on the starboard side. The general service accumulator carried in the aeroplanes is also connected to the starter, but as its capacity is small for such heavy duty it should be used only as a stand-by.

24. Hand starting.- A starting handle is stowed behind the seat. A hole in the engine cowling panel on the starboard side gives access for connecting the handle to the hand starting gear.
25. Oil dilution.- A push-button for operating the solenoid valve is on the left hand side of the cockpit.
26. Engine instruments.- The engine instruments are grouped on the right hand side of the instrument panel and consist of an engine-speed indicator (14), fuel pressure gauge (15), boost gauge (16), oil pressure gauge (17), oil inlet temperature gauge (18), radiator outlet temp. gauge (19), and fuel contents gauge (20). On later aircraft the fuel pressure gauge (15) is replaced by a fuel pressure warning lamp which lights when the pressure drops to 6lb./sq. in.

COCKPIT ACCOMMODATION AND EQUIPMENT

27. Pilot's seat control.- The seat (34) is adjustable for height by means of a lever on the right hand side of the seat.
28. Safety harness release.- In order that the pilot may lean forward without unfastening his harness, a release catch (68) is fitted to the right of the seat.
29. Cockpit door.- To facilitate entry to the cockpit a portion of the coaming (37) on the port side is hinged. The door catches are released by means of a handle at the forward end. Two position catches (39) are incorporated to allow the door to be partly opened before taking off or landing in order to prevent the hood from sliding shut in the event of a mishap.
30. Hood locking control.- The sliding hood is provided with spring catches for holding it either open or shut; the catches are released by two finger levers at the forward end of the hood. From outside, with the hood closed, the catches can be released by depressing a small knob at the top of the windscreen. Provision is made on the door to prevent the hood from sliding shut if the aeroplane overturns on landing.
31. Direct vision panel.- A small knock-out panel is provided on the right hand side of the hood for use in the event of the windscreen becoming obscured.

32. Cockpit lighting.- A floodlight (40) is fitted on each side of the cockpit. Each is controlled by a switch immediately below the instrument panel.
33. Cockpit heating and ventilation.- A small adjustable flap on the starboard coaming above the instrument panel is provided for ventilation of the cockpit. The flap is opened by turning a knurled nut underneath the flap.
34. Oxygen.- A standard regulator unit (6) is fitted on the left hand side of the instrument panel and a bayonet socket (63) is on the right hand side of the cockpit. A separate cock (72) is provided in addition to the regulator.
35. Mirror.- A mirror providing a rearward view is fitted at the top of the windscreen.
36. Map cases.- A metal case (49) for a writing pad and another (54) for maps, books etc. are fitted on the left hand side of the cockpit. Stowage (65) for a height-and-air-speed computer is provided below the wireless remote contactor.

OPERATIONAL EQUIPMENT AND CONTROLS

37. (a) Guns and Cannon.- The machine guns and cannon are fired pneumatically by means of push-buttons on the control column spade grip. The compressed air supply is taken from the same source as the brake supply, the available pressure being shown by the gauge (2).
- (b) The single push-button for firing the eight machine guns on the Spitfire VA. is surrounded by a milled sleeve which can be rotated by a quarter of a turn to a safe position in which it prevents operation of the button. The SAFE and FIRE positions are engraved on the sleeve and can also be identified by touch, as the sleeve has an indentation which is at the bottom when the sleeve is in the SAFE position and is at the side when the sleeve is turned to the FIRE position.

- (c) The triple push-button (11) for firing the machine guns and cannon on the Spitfire VB is fitted with a milled finger which extends out of the bottom and is a means of locking the button in the SAFE position, SAFE and FIRE being engraved on the adjacent casing. When the catch is in the FIRE position, a pip also extends out of the top of the casing so that the pilot can ascertain by feel the setting of the push button.
- (d) The cannon cocking valve (67) is mounted on the starboard side of the cockpit.
38. (a) Reflector gun sight.- For sighting the guns and cannon a reflector gun sight (12) is mounted on a bracket above the instrument panel. A main switch and dimmer switch are fitted below the mounting bracket. The dimmer switch has three positions marked OFF, NIGHT and DAY. Three spare lamps for the sight are stowed in holders (61) on the right hand side of the cockpit.
- (b) When the sight is used during the day the dimmer switch should be in the DAY position in order to give full illumination, and if the background of the target is very bright, a sun-screen (10) can be slid behind the windscreen by pulling on the ring (9) at the top of the instrument panel. For night use the dimmer switch should be in the NIGHT position; in this position a low-wattage lamp is brought into circuit and the light can be varied by rotating the switch knob.
39. (a) Camera.- A G.425 cine-camera is fitted in the leading edge of the port plane, near the root end, and is operated by the gun-firing button on the control column spade grip, a succession of exposures being made during the whole time the button is depressed. When cannon are fitted the cine-camera is operated off the cannon-firing pipe line.

- (b) A footage indicator and an aperture switch are mounted on the wedge plate (38) above the throttle lever. The switch enables either of two camera apertures to be selected, the smaller aperture being used for sunny weather. A main-switch (53) for the cine-camera is mounted on the left hand side of the cockpit. The camera can also be controlled independently by means of an electrical push switch on the control column spade grip, below the gun firing control button.

NAVIGATIONAL, SIGNALLING AND LIGHTING EQUIPMENT

40. (a) Wireless.- The aeroplane is equipped with a combined transmitter-receiver, either type T.R.9D or T.R.1133, and an R.3002 set.
- (b) With the T.R.9D installation a type C mechanical controller (45) is fitted on the port side of the cockpit above the throttle lever and a remote contactor (21) and contactor master switch are fitted on the right hand side of the cockpit. The master contactor is mounted behind the pilot's headrest and a switch controlling the heating element if fitted on the forward bracket of the mounting. The heating element should always be switched OFF when the pilot leaves the aeroplane. The microphone/telephone socket (74) is fitted on the right-hand side of the pilot's seat. The R.3002 push buttons (86) are on the right-hand side of the cockpit, and the master switch (69) immediately aft of these.
- (c) With the T.R.1133 installation the contactor gear and microphone/telephone socket are as for the T.R.9D installation, but the type C mechanical controller is replaced by a push-button electrical control unit.
41. (a) Navigation and identification lamps.- The switch (46) controlling the navigation lamps is on the instrument panel.
- (b) The upward and downward identification lamps are controlled from the signalling switchbox (62) on the right-hand side of the cockpit. This switchbox has a switch for each lamp and a morsing key, and provides for steady illumination or morse signalling from each lamp or both. The switch lever has three positions: MORSE, OFF and STEADY.

Amended by A.L. No. 19/G

- (c) The spring pressure on the morsing key can be adjusted by turning the small ring at the top left-hand corner of the switch-box, adjustment being maintained by a latch engaging one of a number of notches in the ring. The range of movement of the key can be adjusted by opening the cover and adjusting the screw and locknut at the centre of the cover.
42. Landing lamps.- The landing lamps, one on each side of the aeroplane, are housed in the undersurface of the mainplane. They are lowered and raised by a finger lever (30) below the instrument panel. Each lamp has an independent electrical circuit and is controlled by a switch (29) above the pneumatic control lever (30). With the switch in the central position both lamps are off; when the switch is moved to the left or to the right, the port or the starboard lamp respectively, is illuminated. A lever (32) is provided to control the dipping of both landing lamps. On pulling up the lever the beam is dipped. On later aircraft no landing lamps are fitted.
43. Signal discharger.- A straight pull of the toggle control (58) fires the cartridge out of the top of the fuselage, aft of the cockpit.
- DE-ICING EQUIPMENT
44. (a) Windscreen de-icing.- A tank (78) containing the de-icing solution is mounted on the right-hand side of the cockpit directly above the bottom longeron. A cock (79) is mounted above the tank, and a pump (75) and a needle valve (76) to control the flow of the liquid are mounted below the undercarriage emergency lowering control. Liquid is pumped from the tank to a spray at the base of the windscreen, from which it is sprayed upwards over the front panel of the screen.
- (b) The flow of liquid is governed by the needles valve, after turning ON the cock and pushing down the pump plunger to its full extent. The plunger will return to the extended position on its own, and if required, it can be pushed down again. When de-icing is no longer required the cock should be turned to the OFF position.

45. Pressure head heater switch.- The heating element in the pressure head is controlled by a switch (55) below the trimming tab handwheels. It should be switched off on landing in order to conserve the battery.

EMERGENCY EQUIPMENT

46. Hood jettisoning.- The hood may be jettisoned in an emergency by pulling the lever mounted inside the top of the hood in a forward and downward movement, and pushing the lower edge of the hood outboard with the elbows.
47. Forced landing flare.- A forced landing flare is carried in a tube fixed inside the fuselage. The flare is released by means of a ring grip (56) on the left of the pilot's seat.
48. First aid.- The first aid outfit is stowed aft of the wireless equipment and is accessible through a hinged panel on the port side of fuselage.

ADDENDUM

1. Jettisonable tank controls.- On aeroplanes fitted for carrying a long-range jettisonable fuel tank, the cock control and jettison lever are mounted together on the right-hand side of the cockpit, below the undercarriage control unit. The jettison lever is pulled up to jettison the fuel tank, but cannot be operated until the cock control is moved forward to the OFF position.
2. Fuel tank pressurising.- To meet the possibility of engine cutting due to fuel boiling in warm weather at high altitudes, the main tanks can be pressurised (operative above 20,000 feet). Pressurising, however, impairs the self-sealing of the tanks and should, therefore, be turned ON only when fuel pressure drops to 8 lb./sq. in., or the fuel pressure warning lamp (if fitted) comes on. In very warm weather at very high altitudes a rich cut may occur with the tanks pressurised and pressure must then be turned OFF.
3. Air cleaner.- On tropicalised aeroplanes an air cleaner is fitted and a control is provided for cutting it out should it become choked. This consists of a lever below the throttle quadrant which is pushed forward from COLD to HOT to cut out the cleaner and admit warm air from the engine bay.
4. Desert equipment.- The following desert equipment is stowed in the fuselage of tropicalised aeroplanes, aft of the pilot's seat:

Flying and emergency rations.
Drinking water tank and water bottle.
Screwdriver, adjustable spanner and pair of pliers.
Five signalling strips and mirror.
Very signal pistol and container for six cartridges.

A second cockpit ventilator is fitted on these aeroplanes, on the port coaming above the instrument panel.

Issued with A.L.2

Issued with A.L. No. 20/H.

A.P. 1565E and A.P.2280A & B
Volume I & P.N., Sect. 1

ADDENDUM

The particulars given in the following paragraphs refer only to Seafire I and II aeroplanes and should be read in conjunction with the preceding Section I and Addendum of A.P.1565E, Volume I and Pilot's Notes.

1. Seafire I and II are converted Spitfire VB and VC aeroplanes respectively, the Mark I for deck arrested landings only and the Mark II for catapulting or accelerated take-offs and deck arrested landings. Both are fully tropicalised and are fitted with Rotol 35° constant speed propellers. The layout of the cockpit controls and equipment is similar, and the additional items given below are shown in Figures 3 and 5.
2. Arrester gear release control.- The release handle (96) to the right of the pilot's seat is painted yellow and must be pulled forward about 1½ inches to release the arrester hook.
3. Arrester gear warning light.- The light (84) is on the left-hand side of the instrument panel and shows green when the arrester hook is lowered for landing.
4. Air intake control.- The control lever (87) for operating the shutter in the air intake is fitted below the throttle quadrant.
5. Radio equipment.- The radio equipment comprises the following: T.R.1196 or T.R.1304, R.1147 and R.3108. The pushbutton controller (86) for the T.R.1196 or T.R.1304 is on the left-hand side of the cockpit, above the throttle quadrant, and the morse key (90) for the T.R.1196 is on the right-hand side of the cockpit. The controller (94) and wave tuner (91) for the R. 1147 are also on the right-hand side of the cockpit, together with the R.1147/R.T. selector switch (95). The R.3108 pushbuttons (92) and master switch (93) are immediately below these.
6. Stowage for signal pistol cartridges.- A stowage rack (88) for fourteen cartridges is fitted to the pilot's seat.

Key to Fig.1

- | | | | |
|------|----------------------------------|------|-------------------------------------|
| 2. | Brake triple pressure gauge. | 15. | Fuel pressure warning lamp. |
| 3. | Elevator tabs position indicator | 16. | Boost pressure gauge. |
| 5. | Undercarriage position indicator | 17. | Oil pressure gauge. |
| 6. | Oxygen regulator. | 18. | Oil temperature gauge. |
| 7. | Flaps control | 19. | Radiator temperature gauge. |
| 8. | Blind flying instrument panel. | 20. | Fuel contents gauge and pushbutton. |
| 9. | Lifting ring for sun screen. | 24. | Engine starting pushbutton. |
| 9a. | Reflector sight switch. | 24a. | Booster coil pushbutton. |
| 10. | Sun screen. | 24b. | Cockpit light switches. |
| 12. | Reflector sight base. | 46. | Navigation lights switch. |
| 12a. | Voltmeter. | 83. | Ignition switches. |
| 12b. | Ventilator control. | 84. | Arrestor hook warning lamp. |
| 14. | Engine speed indicator. | | (Seafire only). |

A.P. 1565E A.P. 2280A & B, VOL. I, & PN. SECT. 1.

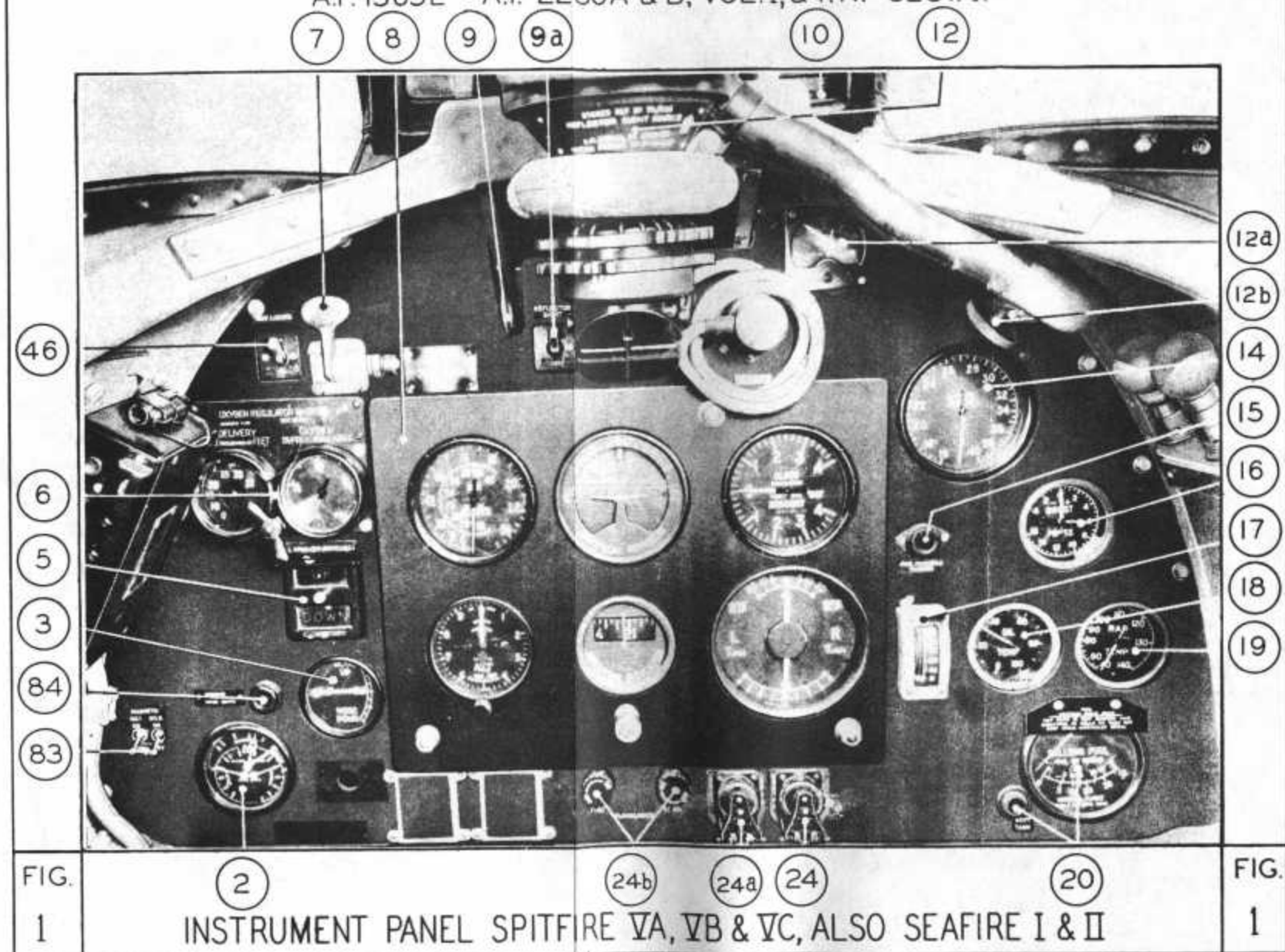
FIG.
1

(2) (24b) (24a) (24) (20)
 INSTRUMENT PANEL SPITFIRE VA, VB & VC, ALSO SEAFIRE I & II

FIG.
1

Key to Figs.2 and 3.

- | | | | |
|------|--|------|---|
| 1. | Boost control cut-out | 50. | Propeller speed control lever. |
| 11. | Gun and cannon three-position push-button. | 51. | Radio controller plug stowage. |
| 11a. | Cine-camera pushbutton. | 52. | Elevator trimming tab handwheel |
| 22. | Slow-running cut-out. | 53. | Camera-gun switch. |
| 23. | Engine priming pump. | 54. | Map case. |
| 25. | Fuel cock control. | 55. | Pressure head heater switch. |
| 28. | Rudder pedal. | 57. | Rudder trimming tab handwheel. |
| 31. | Radiator flap control lever. | 57a. | Oil dilution pushbutton. |
| 38. | Wedge plate for camera footage indicator. | 82. | Rudder pedal adjusting starwheel. |
| 39. | Two position door catch. | 85. | Signal discharger control (Spitfire V only) |
| 40. | Cockpit floodlight. | 86. | T.R.1196 or T.R.1304 controller. |
| 41. | Camera indicator supply plug. | 87. | Air intake control (Seafire and
Tropicalised Spitfire V only). |
| 44. | Undercarriage indicator master. | 88. | Stowage for pistol cartridges (Seafire only) |
| 47. | Control friction adjusters. | | |

AP1565E & AP2280A & B VOL. I & PN SECT. I

(38) (39) (40) (41) (44) (86) (47) (1)

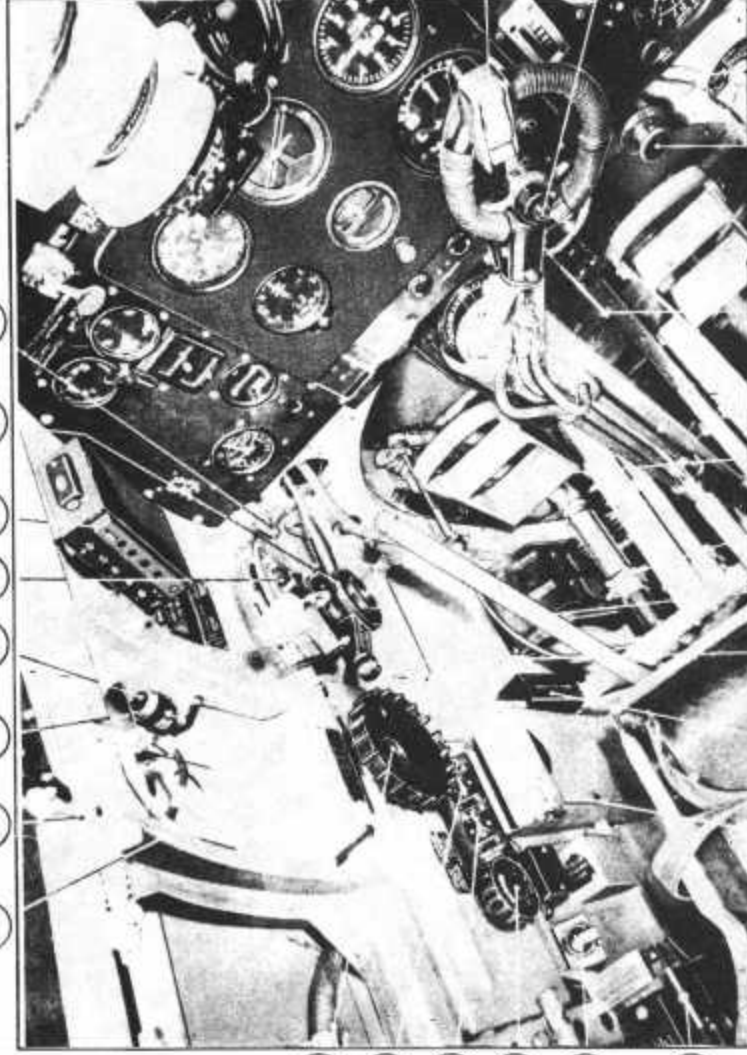
FIG
2FIG
2

PORT SIDE OF COCKPIT - SPITFIRE VA, VB & VC.

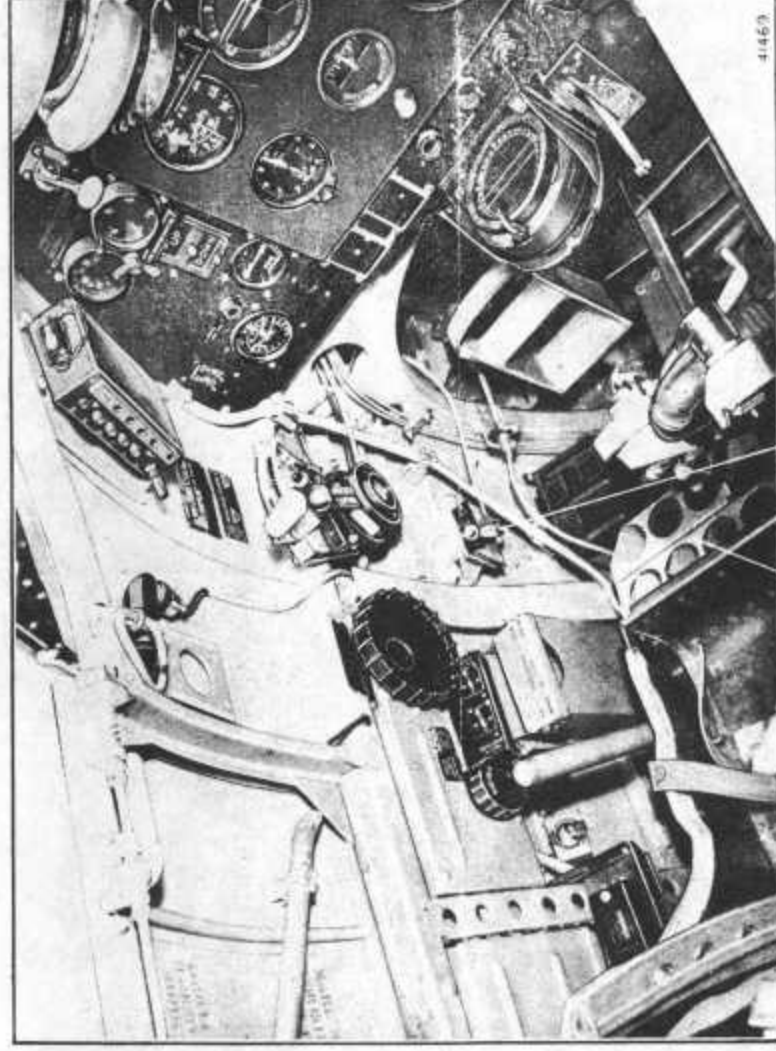
FIG
3FIG
3

PORT SIDE OF COCKPIT - SEAFIRE I & II.

A.P. 1565E & A.P. 2280A & B. VOL. I & P.N. SECT. 1

(61) (62) (64) (21) (66) (68) (69)

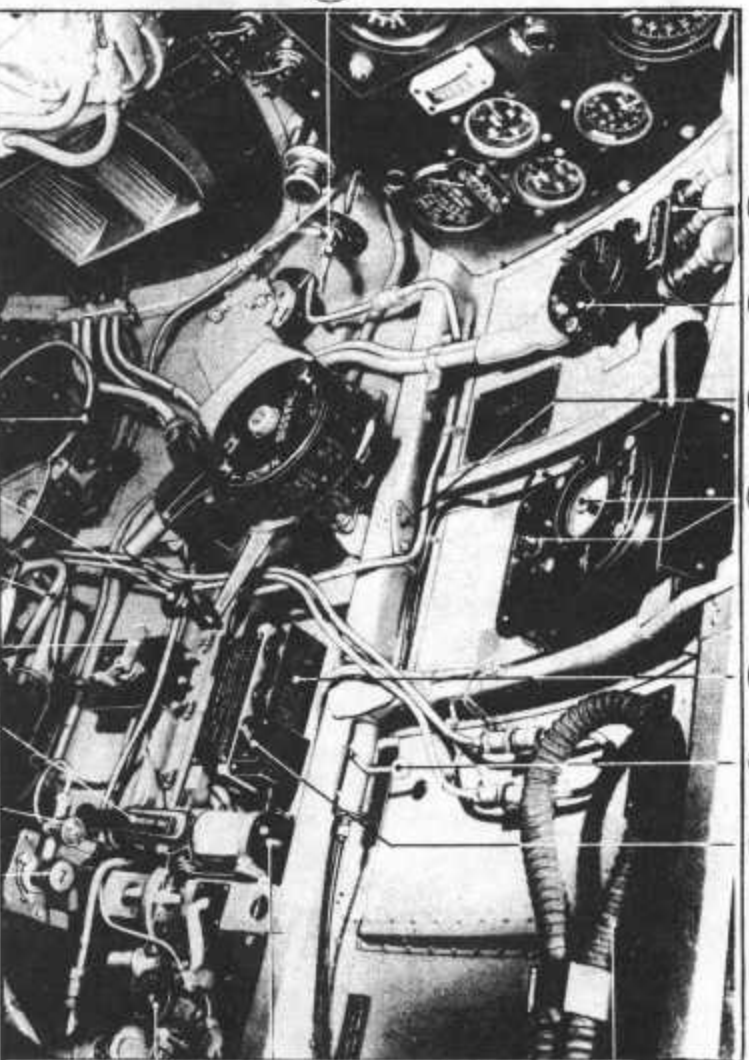

(89)

(71)

(70)

(72)

FIG.
4

STARBOARD SIDE OF COCKPIT - SPITFIRE VA, VB & VC.

(80a) (80) (79d) (79) (77) (76) (75)

(90) (91) (92) (93) (94) (95)

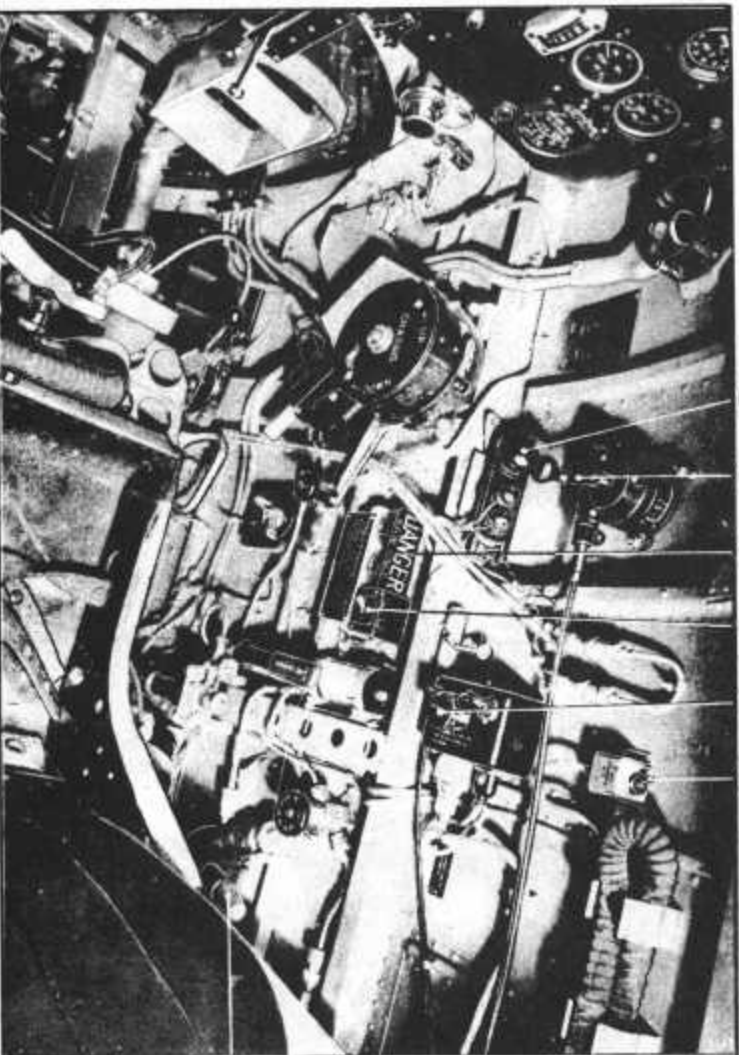
FIG.
4

(96)

FIG.
5

STARBOARD SIDE OF COCKPIT - SEAFIRE I & II

FIG.
5

Key to Figs.4 and 5

- 21. Remote contactor and contactor switch
(Spitfire V only)
- 61. Stowage for reflector sight lamps.
- 62. Signalling switchbox.
- 64. Lug for flying control locking gear.
- 66. R.3002 pushbuttons.
- 68. Harness release control.
- 69. R.3002 master switch
- 70. CO₂ cylinder for undercarriage
emergency system.
- 71. Oxygen mask hose.
- 72. Oxygen supply cock.
- 75. Windscreen de-icing pump.
- 76. Windscreen de-icing needle valve.
- 77. Undercarriage emergency lowering control.
- 79. Windscreen de-icing cock.
- 79a. Jettisonable tank jettison lever.
- 80. Undercarriage control unit lever.
- 80a. Jettisonable tank cock control.
- 89. Fuel tank pressurising cock control.

Fitted on Seafire only:

- 90. T.R.1196 morsing key.
- 91. R.1147 remote control wave tuner.
- 92. R.3108 pushbuttons.
- 93. R.3108 master switch.
- 94. R.1147 controller
- 95. R.1147/R.T. switch.
- 96. Arrestor hook release control.

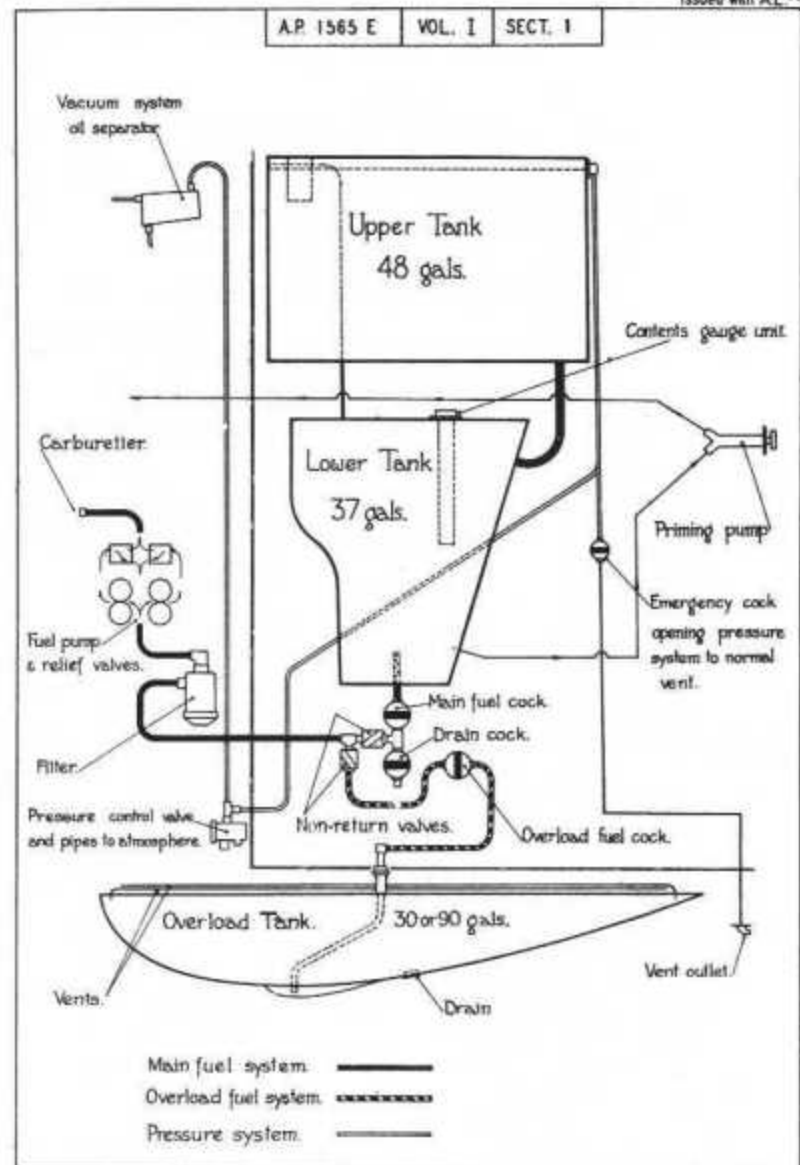

FIG. 6

FUEL SYSTEM DIAGRAM (TROPICAL)

FIG. 6

F548

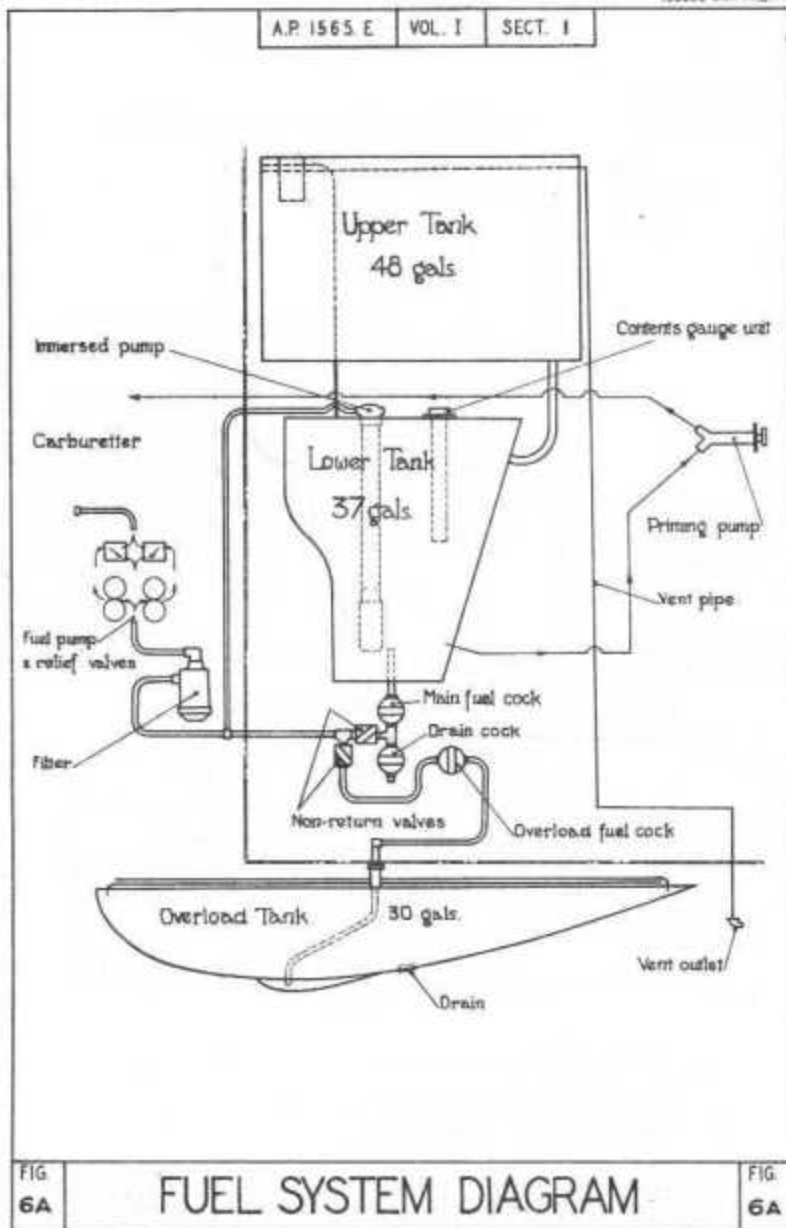

FIG 6A

FUEL SYSTEM DIAGRAM

FIG 6A

SECTION 2
HANDLING AND FLYING NOTES FOR PILOT

Note: The flying technique outlined in these Notes is based on AP.129, Flying Training Manual Part I, Chapter III, and AP.2095, Pilot's Notes General, to which reference should always be made if further information is required.

1. ENGINE DATA: Merlins 45,45M,46,50,50A,50M,55 and 55M.

- (i) Fuel: 100 octane only.
- (ii) Oil: See AP.1464/C.37.
- (iii) Engine limitations:

	R.p.m.	Boost lb/sq.in.	Temp Clnt. °C.	Oil °C.
MAX TAKE-OFF TO 1,000 FEET	3,000	+12	-	-
MAX CLIMBING 1 HR. LIMIT	2,850	+9	125	90
MAX. RICH CONTINUOUS	2,650	+7	105(115)	90
MAX. WEAK CONTINUOUS	2,650	+4	105(115)	90
COMBAT 5 MINS LIMIT	3,000	+16 +18	135	105

- Note:** (a) +18 lb/sq.in. boost is obtained, only on 'M' type engines, by moving the throttle lever through the gate. On other engines +16 lb/sq.in. boost is obtained by operating the boost control cut-out.
- (b) Combat boost is permitted only at 2,850 to 3,000 rpm.
- (c) The figure in brackets is permitted for short periods if necessary.

OIL PRESSURE: NORMAL: 60/80 lb/sq.in.
 MINM: 45 lb/sq.in.

MINM. TEMP. FOR TAKE-OFF: OIL: 150°C
 CLNT: 60°C

FUEL PRESSURE: 8-10 lb/sq.in.

2. FLYING LIMITATIONS(i) Maximum speeds:

Diving:	450 m.p.h. I.A.S.
Undercarriage down:	160 m.p.h. I.A.S.
Flaps down:	160 m.p.h. I.A.S.
Landing lamps lowered:	140 m.p.h. I.A.S.

(ii) Restrictions:

- When fitted with a 90-gallon drop tank the aircraft is restricted to "straight flying" (see A.P. 2095, IA.3) until the tank is jettisoned. This restriction does not apply when fitted with a 30-gallon drop tank.
- For restrictions when carrying 170 and 29-gallon tanks see Para.22.
- Drop tanks should be jettisoned only in straight and level flight, and then only if absolutely necessary.
- When carrying a bomb, spinning is not permitted and violent manoeuvres must be avoided. The angle of dive must at no time exceed 40°.

3. MANAGEMENT OF FUEL SYSTEM

When fitted with a drop tank:

- Start and warm up in the normal way on the main tanks.
- Take off on the main tanks and change over to the drop tank at a safe height (say 2,000 feet). Turn OFF the main tanks.

- Normally the aeroplane should be flown on the jettisonable tank until the fuel is exhausted. When the engine cuts turn ON the main tanks and turn OFF the jettisonable tank at once.
- If the tank is to be jettisoned before the fuel in it is exhausted, first turn ON the main tanks and then move the jettisonable tank cock control to OFF before operating the jettison lever.

Note: The jettisonable tank cock must be kept OFF when the tank is jettisoned or when the fuel in it is exhausted, otherwise air may be sucked into the main fuel system.

- For maximum range and endurance the tank should be jettisoned as soon as the fuel in it has been exhausted.

4. PRELIMINARIES

On entering the cockpit check the following:

- | | |
|------------------------------|--|
| Undercarriage lever | - DOWN
(Check that indicator shows DOWN; switch on light indicator and check that green lights appear). |
| Flaps | - UP |
| Landing lamps | - UP |
| Contents of lower fuel tank. | |

5. STARTING THE ENGINE AND WARMING UP

(i) Set:

- | | |
|-----------------------------|--|
| Fuel cock lever(s) | - ON |
| Throttle | - $\frac{1}{2}$ inch open. |
| Mixture control (if fitted) | - RICH |
| Propeller speed control | - Fully back (D.H.200) or fully forward (Rotol 35° or D.H. Hydromatic) |
| Radiator shutter | - OPEN |

(ii) High Volatility fuel (Stores ref.36A/111) should be used if possible for priming at air temperatures below freezing. Work the priming pump until the suction and delivery pipes are full; this may be judged by a sudden increase in resistance.

(iii) Switch on the Ignition and starting magneto (if fitted) and press the starter and booster coil buttons (if fitted). Turning periods must not exceed 20 seconds, with a 30 seconds wait between each. Work the priming pump as rapidly and as vigorously as possible while the engine is being turned, and it should start after the following number of strokes:

Air temperature °C.:	+30	+20	+10	0	-10	20
Normal fuel:	3	3½	7	12½		
High Volatility fuel:			4	7½	15	

(iv) At temperatures below freezing it will probably be necessary to continue priming after the engine has fired and until it picks up on the carburettor.

(v) When the engine is running satisfactorily, release the booster coil button, or switch off the starting magneto (if fitted), and screw down the priming pump.

(vi) Run the engine as slowly as possible for half a minute, then warm up at a fast tick-over.

(vii) If fitted with a D.H.20° C.S. propeller, move the speed control slowly fully forward when the engine has been running for a minute or more.

6. TESTING ENGINE AND INSTALLATIONS

While warming up:

(i) Make the usual checks of temperatures, pressures and controls. Brake pressure should be at least 120 lb/sq.in.

(ii) See that the cockpit hood is locked open and the emergency exit door is set at the "half-cock" position.

After warming up:

(iii) See that there are TWO men on the tail, and with the propeller speed control fully forward, test as follows:

(a) Open up to maximum boost for WEAK mixture cruising; exercise and check operation of constant speed propeller.

(b) Open the throttle fully and check take-off boost and r.p.m.

(c) At maximum boost for RICH mixture cruising test each magneto in turn. The drop should not exceed 150 r.p.m.

(iv) Running of the engine must not be unduly prolonged because, if the coolant temperature before taxiing out exceeds 100°C, it may become excessive before take-off is completed.

(v) When engines are being kept warm in readiness for immediate take-off, de Havilland 20° C.S. propeller should be left in fine pitch - control lever fully forward.

7. FINAL PREPARATIONS FOR TAKE-OFF

The Drill of Vital Actions is "T,M,P, Fuel, Flaps and Radiator."

T - Trimming tabs - Elevator: about one division nose down from neutral.
Rudder: Fully to st'bd.

M - Mixture control - RICH
(if fitted)

P - Pitch - Propeller speed control fully forward.

Fuel - Cock levers ON and check contents of lower tank.

Flaps - UP

Radiator shutter - Fully open.

8. TAKE-OFF

- (i) Open the throttle slowly to the gate (RATED BOOST position). Any tendency to swing can be counteracted by coarse use of the rudder. If taking off from a small airfield with a full load, maximum boost may be obtained by opening the throttle through the gate to the TAKE-OFF BOOST position.
- (ii) After raising the undercarriage, see that the red indicator light -UP- comes on (it may be necessary to hold the lever hard forward against the quadrant until the indicator light comes on).
- (iii) Do not start to climb before a speed of 140 m.p.h. I.A.S. is attained.

9. CLIMBING

The speeds for maximum rate of climb are as follows:

From S.L. to 10,000 feet:	170 m.p.h. I.A.S.
" 10,000 to 16,000 feet:	160 m.p.h. I.A.S.
" 16,000 to 21,000 feet:	150 m.p.h. I.A.S.
" 21,000 to 26,000 feet:	140 m.p.h. I.A.S.
" 26,000 to 31,000 feet:	130 m.p.h. I.A.S.
" 31,000 to 37,000 feet:	120 m.p.h. I.A.S.
Above 37,000	115 m.p.h. I.A.S.

10. GENERAL FLYING

- (i) Stability: The aircraft is stable about all axes.
- (ii) For normal cruising flight the radiator shutter should be in the minimum drag position.
- (iii) Change of trim:

Undercarriage down	- Nose down
Flaps	- Nose down
- (iv) For combat manoeuvres climbing r.p.m. should be used.
- (v) For stretching a glide in the event of a forced landing, the propeller speed control should be pulled right back and the radiator flap set at the minimum drag position.

11. MAXIMUM RANGE

- (i) Climbing:
Climb at +9 lb/sq.in. boost and 2,850 r.p.m. at the speed recommended for maximum rate of climb. Mixture control (if fitted) at RICH.
- (ii) Cruising:
Maximum range will be obtained at intermediate heights. The recommended speeds are as follows:
 - (a) Without auxiliary tanks, or if fitted with 30 gallon drop tank:

Below 8,000 feet:	180 m.p.h. I.A.S.
Between 8,000 and 15,000 feet:	160 m.p.h. I.A.S.
Above 15,000 feet:	150 m.p.h. I.A.S.

At very low altitude the speed may be increased to 200 m.p.h. I.A.S. without seriously affecting range.
 - (b) If fitted with 90 gallon drop tank:

Below 8,000 feet:	180 m.p.h. I.A.S.
Above 8,000 feet:	170 m.p.h. I.A.S.

Fly in WEAK mixture (if control fitted) at maximum obtainable boost not exceeding +4 lb/sq.in. (the mixture richens automatically at higher boosts) and reduce speed by reducing r.p.m., which may be as low as 1,800 if this will give the recommended speed, but check that generator is charging. If at 1,800 r.p.m. the speed is higher than that recommended, reduce boost.

Note: For maximum range when fitted with 170 gallon and 29 gallon auxiliary fuel tanks see para. 22.

12. STALLING

- (i) At the stall one wing will usually drop with flaps either up or down and the aircraft may spin if the control column is held back.
- (ii) This aircraft has sensitive elevators, and if the control column is brought back too rapidly in a manoeuvre such as a loop or a steep turn, stalling incidence may be reached and a high speed stall induced. When this occurs there is a violent shudder and clattering noise throughout the aircraft which tends to flick over laterally, and unless the control column is put forward instantly, a rapid roll and spin will result.

(iii) Stalling speeds when loaded to about 6,400 lbs are:

Flaps and undercarriage up: 73 m.p.h. I.A.S.
 " " " down: 64 m.p.h. I.A.S.

13. SPINNING

(i) Spinning is permitted by pilots who have written permission from the C.O. of their squadron (C.F.I. of an O.T.U.). The loss of height involved in recovery may be very great, and the following height limits are to be observed:

- a) Spins are not to be started below 10,000 feet.
- b) Recovery must be started not lower than 5,000 feet.

(ii) A speed of over 150 m.p.h. I.A.S. should be attained before starting to ease out of the resultant dive.

14. AEROBATICS

The following speeds are recommended:

Looping: Speed should be about 300 m.p.h. I.A.S., but may be reduced to 220 - 250 m.p.h. I.A.S. when the pilot is fully proficient.

Rolling: Speed should be anywhere between 180 and 300 m.p.h. I.A.S. The nose should be brought up about 30° above the horizon at the start, the roll being barrelled just enough to keep the engine running throughout.

Half-roll off loop: Speed should be 320-350 m.p.h. I.A.S.

Upward roll: Speed should be about 350-400 m.p.h. I.A.S.

Flick manoeuvres: Flick manoeuvres are not permitted.

15. DIVING

- (i) The aircraft becomes very tail heavy at high speed and must be trimmed into the dive in order to avoid the dangers of excessive acceleration in recovery. The forward trim should be wound back as speed is lost after pulling out.
- (ii) A tendency to yaw to the right should be corrected by use of the rudder trimming tab.

16. APPROACH AND LANDING

- (i) During the preliminary approach see that the cockpit hood is locked open, and the emergency exit door is set at the half-cock position. Take care not to get the arm out into the airflow.
- (ii) Reduce speed to 140 m.p.h. I.A.S. and carry out the Drill of Vital Actions "U, M, P and Flaps".

U - Undercarriage - DOWN (Watch indicators and check green lights).

M - Mixture control - RICH (if fitted)

P - Propeller control - Fully forward

Flaps - DOWN

(iii) Approach speeds (m.p.h. I.A.S.): (flaps up)

Engine assisted:	85	(95)
Glide:	95	(100)

- (iv) When lowering the undercarriage hold the lever fully forward for about two seconds. This will take the weight off the locking pins and allow them to turn freely when the lever is pulled back. The lever should then be pulled back smartly to the down position and left there. It should NOT be pushed into the gate by hand. As soon as the undercarriage is locked down the lever should automatically spring into the gate and the hydraulic valve indicator return to IDLE. If it cannot be pulled fully back, hold it forward again for at least two seconds. If it becomes jammed it may generally be released by a smart blow of the hand. If this fails it is necessary to take the weight of the wheels off the locking pins, either by pushing the nose down sharply or by inverting the aircraft. The lever can then be pulled straight back.

Re-issued with A.L.No.28/J.

- (v) If the green indicator light does not come on, hold the lever fully back for a few seconds. If this fails, raise the undercarriage and repeat the lowering. If this fails also, use the emergency system (see Section 1, Para.12).

Note: Before the emergency system can be used, the control lever must be in the down position. It may be necessary to push the nose down or invert the aircraft in order to get the lever down.

- (vi) If the undercarriage is lowered too late on the approach, with insufficient engine speed to develop full hydraulic pressure, the selector lever may not automatically spring from the fully back position into the gate, so indicating that the operation is not complete. This may cause the undercarriage to collapse on landing. (As previously mentioned, the lever must NOT be pushed into the gate by hand). It is advisable, therefore, to lower the undercarriage early on the circuit prior to landing and not in the later stages of the approach.

- (vii) Mislanding: Climb at about 120 m.p.h. I.A.S.

17. AFTER LANDING

- (i) Raise the flaps before taxiing.
- (ii) If fitted with a D.H.200C.S. propeller, after taxiing in set the speed control fully back and open up the engine sufficiently to change pitch to coarse.
- (iii) Run the engine at 800-900 r.p.m. for two minutes, then pull the slow-running cut-out and hold it out until the engine stops.
- (iv) Turn OFF the fuel cocks and switch OFF the ignition.

18. OIL DILUTION

See A.P.2095/4. The dilution period should be:

Atmospheric temperatures above -10°C: 1 minute
Atmospheric temperatures below -10°C: 2 minutes.

19. FLYING AT REDUCED AIRSPEEDS

In conditions of bad visibility near the ground, reduce speed to about 120 m.p.h. I.A.S. and lower the flaps. The radiator shutter must be opened to keep the temperature at about 100°C and the propeller speed control should be set to give cruising r.p.m.

Amended by A.L.No.28/J

A.P.1565E P.N. Sect.2.

20. POSITION ERROR

From	100	140	160	180	200	240	270	6	m.p.h.	I.A.S.
To	140	160	180	200	240	270	over		m.p.h.	I.A.S.
Add	4	2	0	-	-	-	-		m.p.h.	
Subtract	-	-	-	2	4	6	8		m.p.h.	

21. FUEL CAPACITIES AND CONSUMPTION

(i) Fuel:

Normal Capacity:

Top tank	48 gallons
Bottom tank:	37 gallons
<u>Total:</u>	<u>85 gallons</u>

Long-range capacities:

With 30 gallons drop tank:	115 gallons
With 90 gallons drop tank:	175 gallons
With 170 gallons drop tank and 29 gallons rear fuselage tank:	284 gallons

(ii) Oil:

Normal Capacity: 5.8 gallons

Long-range capacity:

With 90 gallon tank:	8.5 gallons
With 170 + 29 gallon tank:	14.5 gallons.

(iii) Fuel consumption (approximate gals/hr.):

- (a) WEAK mixture (or as obtained at +4 lb/sq.in. boost and below if control not fitted) at 6,000 - 20,000 feet:

Boost lb/sq.in.	R.p.m.				
	2,650	2,400	2,200	2,000	1,800
+4	56	53	51	47	43
+2	51	48	46	43	39
0	47	44	42	39	35
-2	43	40	38	35	31
-4	39	36	34	31	26

- (b) RICH mixture (or as obtained above +4 lb/sq.in. boost if control not fitted):

R.p.m.	Boost lb/sq.in.	Gals/hr.
3,000	+9	88
2,850	+9	84
2,650	+7	67

22. MANAGEMENT OF 170 AND 29 GALLON AUXILIARY FUEL TANKS

- (i) The aircraft is restricted to straight flying until the drop tank and the rear fuselage tank are empty.
- (ii) It is most important that at no time should the drop tank cock and the rear fuselage tank cock be ON together, or fuel in the rear fuselage tank will be lost. This applies whether or not the tank has been jettisoned.
- (iii) The drop tank should be jettisoned only in straight and level flight.
- (iv) Start, warm up and take-off on the main tanks, and change over to the drop tank at a safe height (say 2,000 feet). Turn OFF the main tanks.
- (v) When the engine cuts, turn OFF the drop tank, turn ON the rear fuselage tank, and if maximum range is required, or in other special circumstances, jettison the tank at once. If the tank is carried throughout the flight, the still air range is reduced by approximately 120 miles.
- (vi) If the tank has to be jettisoned before it is empty, first turn ON the main tanks and then turn OFF the drop tank. Then change over to the rear fuselage tank when convenient.

NOTE: The drop tank cock must be OFF when the tank is jettisoned, otherwise air may be sucked into the main fuel system, and fuel from the rear fuselage tank will be lost.

- (vii) When the engine cuts again, turn OFF the rear fuselage tank and turn ON the main tanks.
- (viii) Climb in RICH mixture (if control fitted) at +9 lb/sq.in. boost and 2,850 r.p.m. at 170 m.p.h. I.A.S.
- (ix) For level cruising flight the following are the recommended speeds:
 - (a) With 170 gallon tank on:
185 m.p.h. I.A.S. at start of level flight, reducing, as fuel is consumed to 170 m.p.h. I.A.S. when the drop tank is empty.

- (b) After jettisoning tank and while using fuel in rear fuselage tank (for medium or high altitudes):
170 m.p.h. I.A.S. when the rear fuselage tank is full, reducing, as fuel is consumed, to 160 m.p.h. I.A.S. when the rear fuselage tank is empty.

NOTE: At low altitude the recommended speed is 180 m.p.h. after jettisoning tank.

- (x) Fly in WEAK mixture (if control fitted) at +4 lb/sq.in. boost (if obtainable) (do not exceed +4 lb/sq.in. because the mixture is automatically richened at boosts in excess of this) and reduce speed by reducing r.p.m. which may be as low as 1,800 (but check that generator is charging). By reducing r.p.m. by 50 at the end of each half-hour the I.A.S. will be reduced by approximately the correct amount. If at 1,800 r.p.m. the speed is higher than that recommended, reduce boost.

ADDENDUM

The particulars given in the following paragraphs refer only to Seafire I and II aeroplanes and should be read in conjunction with the preceding Section 2 of A.P.1565E, Volume I and Pilot's Notes.

1. Deck take-off.-

- (i) Warming up should not be unduly prolonged, because radiator temperature immediately before take-off must not exceed 100°C.
- (ii) The Drill of Vital Actions is the same as that for normal take-off, except that flaps should be lowered 18°. On aeroplanes in which Mod.No. 63 has not been incorporated this flap setting is obtained as follows:
 - (a) Lower flaps fully, have flight deck crew insert wooden blocks, and then raise flaps.
 - (b) After take-off lower flaps fully at a safe height and then raise flaps.

2. Deck landing.-

- (i) On approaching the carrier before landing, reduce speed to 120 knots I.A.S. and lower the arrester hook. Check that indicator light shows green.
- (ii) The lowering of the hook should preferably be done before breaking formation, where applicable, as an additional check can then be made by pilots of other aeroplanes.
- (iii) See that the cockpit hood is locked open and check brake pressure (at least 120 lb./sq.in.)
- (iv) The DRILL of VITAL Actions is U,P, Hook and Flaps:
 - U - Undercarriage - DOWN (Check green lights).
 - P - Propeller control - Fully forward
 - Hook - Down (Check green light).
 - Flaps - DOWN
- (v) Speed for preliminary approach: 70 knots I.A.S.
Speed for final approach: 65 - 70 knots I.A.S.

