

T.O. 36-1-3

PAINING AND MARKING OF USAF VEHICLES

REVISION
NOTICE

LATEST REVISED PAGES SUPERSEDE
THE SAME PAGES OF PREVIOUS DATE

Insert revised pages into basic
publication. Destroy superseded pages.

PUBLISHED UNDER AUTHORITY OF THE SECRETARY OF THE AIR FORCE

15 SEPTEMBER 1958

REVISED 3 AUGUST 1959

TABLE OF CONTENTS

Section	Page
I GENERAL	1
1. Purpose	1
2. General	1
II PAINTING OF VEHICLES	1
1. Requirement for Painting	1
2. Authorized Colors	1
3. Repair of Damaged Sheet Metal	2
4. Cleaning and Preparation of Surfaces	2
5. Masking	3
6. Prime Coats	4
7. Finish Coats	4
8. Undercoating	4
9. Spray Gun Procedures	5
10. Safety Precautions	5
III MARKING OF VEHICLES	6
1. General	6
2. Types of Markings	7
3. Sizes of Markings	7
4. Location of Vehicle Identification Markings	8
5. National Symbol	9
6. Installation Markings	9
7. Tactical Markings	10
8. Weight-Class Markings	10
9. Decalcomanias	10
10. Special Markings	11
11. Exemptions	18
IV ILLUSTRATED GUIDE TO VEHICLE MARKINGS	18
1. Figures	18
2. Index to Figures	18
V MATERIAL REQUIRED FOR PAINTING AND MARKING	43
1. Supply Information	43



SECTION I

GENERAL

1. PURPOSE.

The purpose of this technical order is to provide instructions and procedures for painting and marking vehicles assigned to the USAF.

2. GENERAL.

a. The provisions herein apply to all vehicles assigned to the USAF.

b. The term "vehicles" includes wheeled, track-laying, and combined wheeled and track-laying vehicles and chassis powered by a self-contained power unit, trailers, and semitrailers.

SECTION II

PAINTING OF VEHICLES

1. REQUIREMENT FOR PAINTING.

a. Vehicular equipment will be repainted when it is determined that inadequate protection is afforded against rust or corrosion. Equipment will not be repainted merely to change the color or gloss characteristics when the finish is serviceable, except as indicated in paragraph 1. b.

b. The commanding officer concerned may authorize refinishing of vehicles in colors specified in paragraph 2., section II, when safety factors are involved.

c. Spot painting, in lieu of complete refinishing, of previously painted sections which have not been properly blended will be accomplished to the greatest extent considered practicable.

d. Bare surfaces of sections of bodies and sheet metal, which have become exposed by deterioration of paint or by accidents, will be immediately spot painted to prevent deterioration of the metal.

2. AUTHORIZED COLORS.

a. For camouflage purposes, commanders in overseas areas are authorized deviation from the colors stated herein.

b. All Air Force vehicles will be painted with full gloss, blue, color number 516, except as specified below:

(1) Crash, fire and rescue, structural fire fighting, and other vehicles assigned for fire protection, will be painted full gloss, red, color number 1105.

(2) Refuse trucks will be painted full gloss, white, color number 1755.

(3) Aircraft servicing units and flight line vehicles will be painted full gloss, yellow, color number 1320, until stocks are exhausted; then use yellow, color number 1310.

(4) Vehicles used for service construction, maintenance, and emergency purposes on landing strips, taxiways, perimeter roads, aircraft flight areas, etc., will be painted full gloss, yellow, color number 1320, until present stocks are exhausted; then use yellow, color number 1310. Ambulances are excluded from the foregoing procedure.

(5) In areas where snow or sand-covered terrain is prevalent, the top surfaces of the hoods of the vehicles may be temporarily covered or painted black to provide protection from excessive sun glare. This procedure will be accomplished at the discretion of the commanding officer concerned.

(6) In areas where extreme heat is prevalent, inside temperature can be reduced by painting the top surfaces of cabs and bodies white, full gloss, color number 1775, within the following limitations:

(a) Vehicles which, by mission assignment, are in a stationary position with personnel required to remain in cab for operating the equipment.

(b) Semitrailer vans and regular vans, such as communications, photographic, repair shop, etc., within which personnel are required to remain in the performance of duty assignment.

(c) Painting of tops under the conditions stated above will be accomplished at the discretion of the commanding officer concerned.

(7) Forklifts, trucks, tugs, tractors, and trailers operated exclusively in warehouses and/or warehouse docks will be painted full gloss, yellow, color number 1320, until stocks are exhausted; then

use yellow, color number 1310.

(8) Sheet metal sections of station wagons will be painted blue when repainting is required. The original natural finish of wood body parts of these vehicles will be retained when practicable.

(9) When repainting is required, the inside of the engine, pumping, and hose reel compartment of aircraft fuel servicing units will be painted full gloss, yellow, color number 1320, until stock is exhausted; then use yellow, color number 1310.

(10) The following color coats will be used for finishing the interior surfaces of vehicles:

(a) Ambulances—full gloss, white, color number 1755.

(b) Closed type vehicles, such as panel trucks, vans, instrument shops, etc. (personnel carriers not included)—semigloss, green, color number 2415. When necessary to refinish the interior of truck or tractor cabs, the original color will be utilized, except that white, yellow, or aluminum color will not be used.

(c) Closed type vehicles, such as pickup trucks, carryalls, etc.—full gloss, blue, color number 516, will be used.

(d) The original color of sedans should be utilized when repainting is required. If this is impractical, use blue, color number 516.

(e) Buses, such as models K-5, K-7, L-162, etc.—semigloss, green, color number 2415. The original finish will be retained on integral type buses when practicable. Floors and matting will be painted black.

(11) Engines, engine accessories, and components requiring repainting will be painted with full gloss, gray, color number 1610.

(12) Assemblies, subassemblies, and accessories, other than engines and engine accessories, requiring refinishing after overhaul or repair will be painted the color previously painted, except that those items previously painted olive drab will be painted blue.

(13) Exteriors of radiator cores will be painted with one thin coat of black lacquer.

(14) Vehicles used by Office of Special Investigation for security reasons may be painted colors other than specified herein.

3. REPAIR OF DAMAGED SHEET METAL.

The prime requisite for high quality, smooth, even finish on vehicles depends upon the preparation

of sheet metal sections of body, etc., prior to painting. The specific type of vehicle concerned should be a governing factor in the determination of the quantity of man-hours to expend for repair of sheet metal damage.

a. All bumps and dents causing any change in the original contour of sheet metal will first be roughed out by a pneumatic hammer if justified by accessibility of damaged area and extent of required repairs. Hydraulic jacks and heat may be applied as necessary. Areas of old paint may be removed with a grinder equipped with a grade four grinding disk, prior to filing. On sedans, a metal file will be used to obtain smoothness, removing file marks with a grade two disk on grinder. Grinder marks may be removed and feather edging may be accomplished with electric or air-driven sanders, using grade zero production paper cut to proper size of disk. A grade three disk may be used on heavy duty vehicles to conserve man-hours and in cases where maximum perfection is not justifiable or required.

b. Rough areas resulting from welding should be removed with a power grinder, using grade two, three, or four abrasive disk, as appropriate.

c. Body solder may be used where it is determined to be practical and expedient. File solder-filled areas smooth and sand with appropriate grade abrasive disks or sandpaper.

d. Thoroughly remove all excess solder acid, oil, or grease, deposited by solder paddle, with a solution of one part phosphoric acid to two parts water. When mixing acid and water, the acid will always be poured slowly into the water, and the mixture will be stirred. Personnel will wear appropriate protective clothing to prevent acid contact with eyes or skin.

e. Bare metal surfaces will be cleaned and treated immediately with a solution of pretreatment coating, in accordance with specification MIL-C-15328A.

4. CLEANING AND PREPARATION OF SURFACES.

a. Undercarriage of Chassis.

Completely clean the vehicle undercarriage by applying, under pressure, a solution of hot water and vapor cleaning compound. Remove deposits of road tar, oil, and grease from recessed parts of springs, axles, and steering mechanisms.

b. Electrical Equipment.

Protect all electrical equipment, such as generator regulators, generators, starters, distributors, etc., from direct impact with cleaning jets when using vapor or steam cleaning compounds. Disconnect battery cable prior to steam cleaning engine compartments.

c. Engines.

Clean engine exterior, fire wall, steering columns, side pans, and underside of hood, using cleaning compound and hot water.

d. Battery and Carrier.

Wash entire battery and carrier with a solution of sodium bicarbonate.

e. Interior.

Clean dirt from inside of cab, upholstery, and the body.

f. Exterior.

Wash the exterior of the vehicle with a pressure type power washer. Thoroughly wash all glass, head lamp lenses, and safety reflectors. Remove all deposits of cleaning compounds by using compressed air.

g. When the surface to be refinished is checked, cracked, or rusted, remove the paint down to the bare metal. All bare metal surfaces to be painted must be dry and free from all rust and loose scale by wire-brushing, applying pretreatment coating, or flame descaling. This work will not be performed in the spray painting area or where spray painting is in progress.

(1) Spray, brush, or swab pretreatment coating on bare metal surfaces in accordance with specification MIL-C-15328A.

(2) The pretreatment coating should be coated with primer as soon as practicable (preferably within 24 hours), as it loses its effectiveness after a short exposure to adverse weather conditions.

h. Old paint that is in good condition makes an excellent base for repainting and need not be removed. The edges of areas with remaining good paint should be feathered down so that cracks will not develop and breakoffs will not be visible.

i. When paint cannot be sanded to a smooth finish for overspraying without excessive expenditure of man-hours, residual paint may be stripped by use of remover, paint and varnish, Federal stock number 8010-165-5536.

j. Rust preventive compound that has been applied to parts and sections of the sheet metal and bodies may be removed by a spray application of a mixture of one part of compound, grease cleaning, Ordnance stock number 51-C-1581-555; one part trichloroethylene, Federal stock number 6810-223-2734; and three parts kerosine, Federal stock number 6810-261-7453. Allow to penetrate for approximately five minutes; then respray. Before it dries, remove the softened

material with a steam cleaner. If removal is incomplete and reapplication of the solvent is considered necessary, water condensed from the steam cleaning must be allowed to dry completely before respraying with the solvent. This work will be performed only in exhaust-ventilated booths with a minimum face velocity of 200 feet per minute (fpm). Normally no more than one operator will work in the booth at one time, except when operational necessity requires more than one operator in the booth. All operators will wear air respirators, Navy specification 37M3, type A, class II, or type A, class I, and other appropriate protective clothing to avoid skin contact with sprayed solvents.

k. The painted finish may be removed from the body hardware, exterior trim moldings, and bumper bars of prewar sedans, if these parts were originally plated with chrome finish. In instances where the chrome finish is deteriorated and replating is considered economically feasible, restoration to original finish may be made. Where facilities and/or funds are unavailable for replating, these parts may be painted with applicable color coat when they are rusted or damaged excessively.

5. MASKING.

a. Prior to spray gun operation, it is necessary to cover or mask all parts, such as windows, rubber and chrome moldings, gages, lubrication fittings, data plates, instructions, and similar components, which are not required to be painted. Unpainted radiator cores will also be masked to prevent the application of paint which may contribute to overheating of cooling system. Radiator cores originally painted by the contractor will be repainted only to the extent necessary to prevent corrosion.

NOTE

Data plates will be covered with masking tape in lieu of being removed.

b. Small areas or irregularly shaped parts will be covered with crepe-backed masking tape. Large areas will require a sheet of wrapping or other paper slightly smaller than the part to be masked. This will be held in place by a strip of masking tape. Overlap the edge of the paper with tape applied to the surfaces being masked. Masking provides a convenient method for spray-painting to irregular outlines.

c. Paste-Like materials may be applied to areas where paint is not desired. When the paint is dry, these areas may be wiped clean.

d. When spraying engines, the use of bandages and sock, instead of masking tape, to protect rubber hose, ignition wires, and flexible tubing saves much time and material. The bandages will be fabricated

from pieces of cloth cut to fit the part to be covered, the length being determined by the length of the object, allowing the bandage to overlap about one-half the circumference. Drawstrings at each end and a string around the center of the bandage will prevent overspray from contacting the protected part. The sock is a cloth bag which fits over the ignition wires and distributor cap and has a drawstring which is drawn and tied below the distributor cap.

e. When applying the markings prescribed in section III, consideration should be given to the local purchase of strips of reflectorized tape and to the use of precut paper masks in lieu of stencils. These items may be purchased locally in accordance with Air Force Regulation 67-3.

6. PRIME COATS.

a. The first coat of primer-surfacer will be applied within 24 hours after completion of cleaning or treatment of bare metal surfaces. Allow to dry thoroughly, then sand lightly.

b. Apply one or two coats, as required, of sealer, surface, Federal stock number 8010-598-5451, to wood surfaces of vehicle bodies, allowing a minimum of one hour drying time between coats.

(1) Apply a medium coat of bituminous paint, Federal stock number 8030-664-4969, to undersurfaces of wood floor decking.

(2) When it becomes necessary to replace wooden floors of trucks and trailers, the material used should be hardwood, and the underside and edges should be treated with creosote, prior to installation.

7. FINISH COATS.

a. Enamel.

(1) Apply one coat of enamel of the appropriate color as specified in paragraph 2., section II. This coat should be a thin mixture and should be applied in a manner to facilitate quick drying and to provide a tacky surface for the application of the final coat. This coat should not be allowed to dry thoroughly.

(2) The second or final coat should be applied with a mixture, as prescribed by the paint manufacturer, adequate for complete coverage to produce a smooth even surface free from runs, sags, and overspray.

b. Lacquer.

(1) Lacquer is authorized only when an immediate requirement exists for quick drying due to climatic conditions.

(2) Lacquer may be applied by either hot or

cold application. Use lacquer in accordance with specification MIL-L-7178, thinned with blush retarder thinner, specification MIL-T-6095.

(3) When a vehicle is repainted with lacquer, it will be specified in the vehicle historical record that lacquer was used.

c. Simonizing, waxing, or polishing of USAF vehicles by commercial contract is not authorized. The Maintenance and Supply Group Commander, or his equivalent, will make necessary arrangements with the Base Commander for the utilization of prisoner labor for the polishing and waxing of vehicles. A qualified airman or officer from the Vehicle Squadron should closely supervise this work to insure that proper material and/or procedures are utilized. When prisoner labor is not available for polishing and waxing of vehicles, the driver will be responsible for the care of individual vehicles, regardless of whether the duty is incidental or not.

d. The painted finish of garnish moldings and instrument panels of the interiors of sedans will not be painted if the finish is serviceable and if restoration to original condition can be accomplished by cleaning and by applying wax compound.

8. UNDERCOATING.

a. Vehicles authorized to be coated—new sedans, station wagons, buses, ambulances, and commercial trucks through 1 1/2-ton size—which have not been undercoated will be treated with undercoating during new vehicle inspection and prior to operation or storage. Used vehicles of the types indicated above, that have not been treated previously, will have undercoating applied when complete repainting is required or prior to storage or operation in salt air localities. When these vehicles are utilized in salt air localities or under other severe operating conditions, they may require re-applications of material for continued protection from corrosion.

b. Preparation of Vehicles.

(1) Surface preparation of the areas to be covered by undercoating is very important. To insure proper adhesion and protection to the underbody of the vehicle, the surfaces must be clean, dry, and free from oil, grease, dust, road tar, rust, and other foreign material.

(2) Normally, thorough washing will be sufficient in the preparation of the underbody surfaces of new vehicles.

(3) The undersurfaces of used vehicles to be coated will be cleaned by use of a steam cleaner and high pressure washing equipment, if available, or by thoroughly scraping and brushing. Allow vehicles to dry thoroughly; tighten all loose nuts and bolts; remove rust scales and loose paint; and wipe clean. Touch up any unpainted spots and allow paint to dry

before spraying undercoating compound on vehicle.

c. Do not spray engine, crankcase, "live" axles, drive shafts, springs and shackles, universal joints, differentials, transmissions, lubrication joints, shock absorbers and links, exhaust pipes, mufflers, tail pipes, brake drums, or hand brake mechanisms. Spraying these parts would prevent proper heat dissipation or cause unbalance of revolving and reciprocating parts. Use protective fitting caps for covering all lubricating fittings to prevent clogging of holes when spraying nearby surfaces.

d. Assemblies and Surfaces To Be Undercoated.

The underside of the body, inside and outside of the frame, undersurfaces of fenders, fender wells, running boards, splash aprons, floorboards, and gasoline tanks exposed to deterioration from road debris will be coated with undercoating compound, Federal stock number 8030-291-0334, in accordance with Federal specification TT-C-520.

e. Safety.

The solvent used in the undercoating compound is not toxic and volatile portion of the compound (unthinned) is not vaporized during spraying; therefore, there is little danger of respiratory infection caused by breathing small particles suspended in the air. However, the spray gun operator will be provided with gloves and face shield.

f. Shop Facilities and Ventilation.

(1) A hydraulic lift is preferred for spraying operations, although an elevated rack or pit may be used. Protection shields or curtains, such as a hanging covering which can be drawn up or aside, may be used to protect adjacent areas and personnel against overspraying.

(2) Good ventilation is recommended for the spraying area, even though the compound has a low-volatile solvent and only an extremely small portion of the solvent-vapor concentration is in the surrounding air.

(3) The aforementioned procedure is not necessary or required for crash-rescue and structural fire fighting vehicles assigned for fire protection.

(4) Tugs, wheeled tractors, track-laying tractors, and similar type vehicles not equipped with sheet metal body sections will be excluded from this procedure.

9. SPRAY GUN PROCEDURES.

a. To obtain the best results when spray-painting, the gun should be held perpendicular to the work at all times and approximately six to ten inches from the surface. The proper stroke is made with a free arm

motion, keeping the face of the air cap parallel with the surface at all points on the stroke. The ends of the stroke are feathered out by beginning the stroke before pulling the trigger of the gun and releasing the trigger just before ending the stroke. Avoid arcing the gun during the stroke, to prevent uneven application and excessive overspray at the end of the stroke.

b. Adjust gun to operate at maximum speed consistent with material, rate of flow, surface, and individual skill.

10. SAFETY PRECAUTIONS.

The safety precautions contained in Air Force Manual 32-3 which are applicable to the operation of vehicle paint shops and spray-painting of vehicles will be adhered to during cleaning and repainting of vehicles and ground servicing and powered ground equipment. The following specific safety precautions will be taken to insure the safety of personnel and to prevent accidental damage to equipment.

a. Respirator, air filtering, Navy specification 37M3, or respirator, supplied air, Navy specification 37M3, depending upon severity of exposure, will be worn during all spray-painting operations. Use cartridge type when repeated exposure is encountered.

b. All indoor spray-painting will be accomplished in a vehicular paint spray room equipped with spray booths having a minimum face air velocity of 125 fpm.

c. Preparations containing benzene or benzol will not be used for spraying. Inhalation of these fumes is extremely injurious to health.

d. Never use flammable solvents to clean the walls of spray booths or any part of the vehicle.

e. Smoking is prohibited in the paint shop. The mist that comes from a spray gun is highly flammable, and a spark or flame of any type will cause it to flash or explode.

f. Accumulations of paint-spray dust in booths and in cracks and corners of the paint shop are hazardous, as the spray is highly flammable and thick coatings of it are subject to spontaneous ignition. It also causes deposits on newly painted surfaces when exposed to sudden drafts. To eliminate this hazard, it is essential to keep the paint shop clean. Walls of paint shops and paint-spray booths may be covered with paper, which should be replaced when dirty. The paint and/or paint residue removed from the booth should be removed from the building and safely disposed of immediately, as it is subject to spontaneous ignition.

g. Dirty rags and paper refuse will be kept in separate metal containers with self-closing lids and appropriate markings. The contents will be removed and disposed of at the end of each operating shift.

h. All electrical equipment in the painting area will be of the type required by the National Electric Code and NBFU pamphlet number 33. The equipment will be installed in accordance with the National Electric Code.

i. All supplies of paints, thinners, etc., authorized within the paint room will be kept in a metal cabinet ventilated by vent holes to prevent accumulation of vapors. Thinners, solvents, and other highly volatile, flammable agents will be kept in approved safety cans.

j. All paint-spraying equipment will be kept thoroughly clean and will be inspected frequently to insure that it is in serviceable condition.

k. Frequent inspections will be made of electrical equipment by qualified electricians to insure proper operation and to eliminate fire hazards due to short circuits, defective electric switches, or improper maintenance.

l. Fuel and oil servicing trucks and trailer tanks will be drained of all fuel and oil prior to painting, and the tanks will be completely filled with water or the vapors will be removed with steam, in accordance with Technical Order 36Y31-1-1. The steam hose will be of conductive rubber and will be grounded to the truck; and the truck will also be grounded before steaming operations are started.

m. The paint-spray room or paint-spray booths will be protected by an adequate amount of the proper type fire extinguishers.

n. All personnel engaged in acid or caustic cleaning operations will wear rubber gloves, aprons, boots, goggles, and approved protection equipment.

o. No acid or other oxidizing agents will be permitted in the paint room or stored where they may come in contact with painting materials at any time.

SECTION III

MARKING OF VEHICLES

1. GENERAL.

a. The markings prescribed in this technical order provide a uniform method for identifying vehicles as property of the USAF and serve to associate such property with the organization to which it is assigned.

b. Vehicles may be required to bear all markings described in the technical order or only a portion of those described, depending upon the type of vehicle, its mission, and the safety factors involved.

c. Additions to or deviations from the markings prescribed herein may be made at the discretion of the major command or theater commander concerned where such additions or deviations are required by civil law. The extent of such additions or deviations will be held to an absolute minimum and will be consistent with safe practice.

d. Markings will be clearly maintained on all vehicles at all times except as follows:

(1) Upon transfer from the USAF, all markings except the registration number will be removed.

(2) Upon transfer within the USAF, all organizational markings will be removed.

(3) Upon assignment to private contractors, all markings will be removed from the vehicle. The USAF registration number will be restenciled on the under side of the hood of the vehicle.

(4) Upon permanent transfer to disposal agencies or upon sale to commercial contractors, all Air Force markings, including USAF registration numbers, will be obliterated or removed. Data plates showing chassis and engine service numbers will not be removed.

e. When the requirements for camouflage or concealment outweigh the requirement for identification, the markings prescribed herein may, by direction of the major command concerned, be obliterated with some readily removable substance.

f. Markings will be accomplished by using locally purchased, reverse silk-screened reflectorized tape, conforming with specification MIL-R-13689. Vehicles will be marked with reflectorized material at the next repainting, or when existing markings have been damaged or have deteriorated to the point where re-marking is necessary. Use the following colors:

(1) Red background with silver letters for use on red and yellow surfaces.

(2) Blue background with yellow letters for blue and for white surfaces.

(3) Bicycles and vehicles painted olive drab color will not have reflectorized markings applied.

g. Letters and numerals used for the marking of vehicles will be of heavy Gothic type. Unless

otherwise specified, the size selected will be the largest size practicable in the available space consistent with good appearance and visibility.

2. TYPES OF MARKINGS.

a. Identification Markings.

The term identification includes the following:

(1) Agency identification—U S Air Force or Air National Guard, whichever is applicable.

(2) Registration Number—established and assigned to vehicles in accordance with Air Force Regulation 77-6, applicable to all vehicles.

(3) Legend "For Official Use Only."

b. National Symbol.

The national symbol may be applied to all vehicles operated by the USAF in overseas theaters, by direction of the theater commander concerned.

c. Installation Markings.

Markings will be applied to all vehicles when assigned to, or upon receipt by, the organization or installation by which they are to be operated. The markings will be carried on the vehicle at all times while it is so assigned.

d. Tactical Markings.

Tactical markings are authorized only on vehicles assigned to tactical units and will be removed when vehicles are transferred from the jurisdiction of the commander prescribing their use.

e. Weight-Class Markings.

Weight-Class markings will be applied to each vehicle that is operated within the continental United States when the gross vehicle weight with normal load is 10,000 pounds or greater, and to each towed trailer when the gross vehicle weight with normal load is 4,000 pounds or greater. They may be applied to such vehicles in overseas areas as directed by the theatre commander.

f. Decalcomanias.

Decalcomanias are specified for unauthorized use of motor vehicles and for converting miles per hour to kilometers per hour.

g. Special Markings.

Special markings include safety markings, no-smoking signs, Air Police markings, etc. These markings will be applied as specified in paragraph 10 of this technical order.

3. SIZES OF MARKINGS.

The sizes of the letters and numerals to be used in accomplishing vehicle markings are as follows:

a. Vehicle Markings.

VEHICLE	USAF OR AIR NATIONAL GUARD	REGISTRA- TION NO.	LEGEND
Fuel Serv- icing Trail- ers	4 in.	3 in.	
Crash Fire	4 in.	3 in.	
Buses	4 in.	3 in.	1 in.
Low Bed and Van Type Trailers	4 in.	3 in.	1 in.
Motorcycles	1 in. (Approx) (Size to fit vehicle)	1 in. (Approx)	1 in. (Approx)
Jeep, Model M38A-1	1 in.	1 in.	1 in.
Sedans, Station Wagons, Carry- alls and Subur- bans	1 3/4 in.	1 3/4 in.	1 in.
Oliver Tractor	1 3/4 in.	1 3/4 in.	
Caterpillar, Model D-8	1 3/4 in.	1 3/4 in.	
Caterpillar, Model D-4	1 3/4 in.	1 3/4 in.	
All Other Vehicles	1 3/4 in.	1 3/4 in.	1 in.

b. Reflectorized Markings.

In order to accomplish reflectorized markings on the above vehicles, it will be necessary to local-purchase strips of reflectorized tape containing the information listed below:

- (1) "U. S. AIR FORCE"
(4-inch letters)
- (2) "U. S. AIR FORCE"
(1 3/4-inch letters)
- (3) "U. S. AIR FORCE"
(1-inch letters)

(4) "AIR NATIONAL GUARD"
(4-inch letters)

(5) "AIR NATIONAL GUARD"
(1 3/4-inch letters)

(6) "AIR NATIONAL GUARD"
(1-inch letters)

(7) Registration Numbers 0, 1, 2, 3, 4, 5, 6, 7, 8, 9, B, C, D, E, K, L, M, and N, use three-inch-high figures. These figures will be on separate sheets. Example: All 1's on one sheet, all B's on one sheet, etc.

(8) Registration Numbers 0, 1, 2, 3, 4, 5, 6, 7, 8, 9, B, C, D, E, K, L, M, and N, use 1 3/4-inch figures. These figures will be on separate sheets. Example: All 1's on one sheet, all B's on one sheet, etc.

(9) Registration Numbers 0, 1, 2, 3, 4, 5, 6, 7, 8, 9, B, C, D, E, K, L, M, and N, use one-inch figures. These figures will be on separate sheets. Example: All 1's on one sheet, all B's on one sheet, etc.

(10) "FOR OFFICIAL USE ONLY," one-inch letters.

c. The size of all other markings is included in the paragraph pertaining to the specific marking involved.

4. LOCATION OF VEHICLE IDENTIFICATION MARKINGS.

a. USAF vehicles will be identified on each side and in the rear, in accordance with the following instructions:

(1) Identification on the sides of the vehicle will consist of:

(a) Agency Identification. The top line will consist of the words "U.S. Air Force" or "Air National Guard," whichever is applicable.

(b) Registration Number. The middle line will consist of the USAF registration number assigned to the vehicle. When applying registration numbers on the vehicle, a double space will be left between the letter and the sequence number, in accordance with Air Force Regulation 77-6. Example: 51B 40.

(c) Legend. The bottom line will consist of the legend "For Official Use Only." Special purpose vehicles and materials handling and construction equipment do not require the legend.

(2) Identification on the rear of the vehicle

will consist of (a) the agency identification and (b) the USAF registration numbers. The legend is not required to be displayed on the rear of the vehicle.

(3) Location of Identification.

(a) On passenger cars, station wagons, ambulances, carryalls, suburbans, fire trucks, and truck-tractors, identification will be centered on each front door or in a comparable position in relation to the driver's seat on vehicles without doors.

(b) On trailers, semitrailers, and buses, identification will be centered vertically on each side of the front quarter of the vehicle.

(c) The location of identification on the rear of the vehicle is not prescribed due to the various types of design characteristics involved. The location and arrangement of identification, however, will be such that it will not be exposed to excessive abrasive action under normal operation and so that the vehicle may be easily identified from the rear. If space does not permit, the agency identification will be omitted.

(d) Due to the various types of materials handling equipment, the exact location for identification is not specified. These markings will be applied, using figure 23, section IV, as a guide.

(e) Identification markings on tractors, other than truck-tractor or towing tractor, will be applied as follows, using figure 24, section IV, as a guide.

1. On Oliver tractor, place "U S AIR FORCE REG NO _____" on one line, sides of hood, behind muffler.

2. On caterpillar model D-8, place "U S AIR FORCE" and "REG NO _____" on two lines, sides and rear of seat, one inch between lines.

3. On caterpillar model D-4, place "U S AIR FORCE REG NO _____" on one line, sides of hood, centered; place "U S AIR FORCE" and "REG NO _____" on two lines, rear of vehicle seat, one inch between lines.

(f) On sidecars of motorcycles, identification will be centered vertically on the door or outside panel of the vehicle. On solo motorcycles the location of the identification should be such that it will permit easy identification of the vehicle.

(g) For political or security reasons the markings prescribed above may be waived by overseas commanders in sensitive areas if considered advisable. This authority for waiver does not apply within the United States, its territories or possessions. When an overseas area includes territories or possessions of the United States and exemptions

from the above markings are desired, a specific request for such an exemption will be submitted through Air Force channels to the Department of Defense. Overseas commanders will comply with the prescribed markings to the maximum extent possible, in order that uniformity of the vehicle marking system may be accomplished world-wide.

b. Location of all other markings is included in the paragraph pertaining to the specific marking involved.

5. NATIONAL SYMBOL.

a. A white, five-pointed star is prescribed as the national symbol, which will be used for marking all vehicles assigned to units in overseas operation. This symbol will be applied when directed by the theater commander.

b. The size of the national symbol will vary considerably, depending on the type vehicle concerned. It should be large enough to take full advantage of the surface on which it appears and should utilize the largest clearly visible space.

c. When used, the national symbol will be painted on the hood and on both sides of a vehicle. On horizontal surfaces, the star will be placed so that one of the five points is directed toward the rear of the vehicle. On vertical or nearly vertical surfaces, one point will be squarely up.

d. The national symbol will not be used on vehicles operated in the continental United States.

6. INSTALLATION MARKINGS.

a. Markings for vehicles assigned for use by depots, bases, and airfields will consist of groups (1), (2), and (4) below. Markings for vehicles assigned for use by auxiliary motor pools of depots, bases, and airfields will consist of the four groups listed below:

(1) The first group will indicate the major command to which the vehicle is assigned. This group will consist of letter abbreviations for the command concerned.

ABBREVIATION	COMMAND
AAC	Alaskan Air Command
AAG	Air Advisory Group in China
AFE	Air Force in Europe
AMC	Air Materiel Command
ARDC	Air Research and Development Command

ABBREVIATION	COMMAND
ATC	Air Training Command
AU	Air University
HQC	Headquarters Command
BMC	Brazil Military Commission
CAirC	Caribbean Air Command
CG	Chief of Staff, USAF
CONAC	Continental Air Command
MATS	Military Air Transport Service
PACAF	Pacific Air Force
SAC	Strategic Air Command
TAC	Tactical Air Command

(2) The second group will be the abbreviated designation of the assigned installation. Vehicles stationed at bases, airfields, aircraft control and warning sites, or other installations which do not have a definite Air Force designation, will use the abbreviated designation of the organization to which the vehicles are assigned.

EXAMPLES:

W-PAFB	Wright-Patterson Air Force Base
TAFB	Tinker Air Force Base
KAFB	Kelly Air Force Base
94ABS	94th Air Base Squadron
149ACWS	149th Aircraft Control and Warning Station

(3) The third group will be the abbreviation for the auxiliary motor pool responsible for the dispatch of the vehicle.

EXAMPLES:

A	Area "A" Motor Pool
B	Area "B" Motor Pool
C	Area "C" Motor Pool

(4) The fourth group will indicate the assigned number of the vehicle in the line of march or the number of the vehicle assigned by the motor pool.

EXAMPLES:

5	5th Vehicle
10	10th Vehicle
15	15th Vehicle

b. Air National Guard Vehicles.

Markings for vehicles (except those noted in paragraph 6. c.) assigned by Tables of Authorization (SLOE) to the Air National Guard consist of four

groups: (1) initials "AFNG," (2) abbreviation of the state in which the AFNG Base is located; (3) abbreviation of the city used in the base mailing address; and (4) the local vehicle number.

EXAMPLE: AFNG-NY-SYC-B5-(USAF), Air National Guard, New York, Syracuse, B-5

c. The markings prescribed in paragraphs 6. a. and b. will be applied to all vehicles except metropolitan ambulances, on both the front and rear. On military type vehicles, the markings will be carried on the front and rear bumperettes, as shown in section V. In most cases, bumper face plates installed on sedans, station wagons, 1/2-ton, 4x2 commercial carryalls, and new vehicles that are being furnished to the USAF are either of stainless steel or are chrome plated. Organization markings for these vehicles will be applied on front fenders in the space immediately above front bumpers. Markings will be applied to the rear of these vehicles on body panel immediately above rear bumpers (see section V for an example). No exterior markings will be used when marking metropolitan ambulances, except as specified in paragraphs 3. and 9.

d. Civil Air Patrol Vehicles.

Markings for vehicles assigned to Civil Air Patrol consist of four groups: (1) initials "CAP"; (2) the state abbreviation; (3) the liaison office (LNO); and (4) the vehicle number.

EXAMPLE: CAP-O-LNO-2—USAF, Civil Air Patrol, Ohio, LNO, 2nd Vehicle

e. Reserve Officers' Training Corps Vehicles.

Markings for vehicles assigned to Air Force ROTC consist of three groups: (1) initials "ROTC"; (2) abbreviation of the institution to which the vehicle is assigned; and (3) the vehicle number.

EXAMPLE: ROTC-USC-3—USAF, Reserve Officers' Training Corps, University of Southern California, 3rd Vehicle.

7. TACTICAL MARKINGS.

Tactical markings are prescribed by commanders of tactical organizations. They are used in tactical units only and are not authorized during peace time. They should be designed in such a manner that identification by enemy observation is impossible, while at the same time permitting identification by personnel of the organization to which the vehicle belongs.

8. WEIGHT-CLASS MARKINGS.

a. Weight-Class markings will be applied to each vehicle when the gross vehicle weight with normal load is 10,000 pounds or greater, and to each towed

trailer when the gross trailer weight with normal load is 4,000 pounds or greater. The numerals applied to an individual vehicle or trailer will be its loaded gross weight to the nearest ton. The numerals applied to tractor-semitrailer combination will consist of two numbers arranged one above the other, separated by a horizontal or diagonal line 1/2 inch long. The upper, or left-hand, number will show the weight-class of the combination, which is the gross weight of the heavier vehicle plus 1/2 of the gross weight of the latter unit. The lower, or right-hand, number will show the vehicle class of the tractor alone.

b. Weight-Class markings will be applied in a square (preferably eight inches) immediately to the right of the center of the front bumper of conventional vehicles. In certain instances, it may be desirable to place this marking on the right front fender, provided the available space is suitable. Markings will be placed on the right side and near the front of all trailers with weight-class of 4,000 pounds or greater.

EXAMPLE (1/8 actual size):

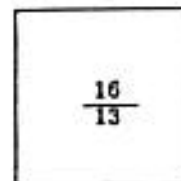

c. Tractors, with and without dozers, that are not equipped with bumpers will be marked in a position visible from the front. If necessary, a locally fabricated plate will be attached to the radiator.

d. Road graders will be marked on the flat vertical surface at the front of the grader.

e. All other vehicles will be marked by following as closely as possible the procedures outlined in paragraphs 8. b., c., and d., section III.

9. DECALCOMANIAS.

a. Display and Penalty for Unauthorized Use.

(1) Penalty for Unauthorized Use of Motor Vehicles.

Each passenger motor vehicle shall display a decalcomania with the following quotations from Public Law 600, 79th Congress, conspicuously mounted in front of the driver and as near as possible to the center of the instrument panel:

"Any officer or employee of the Government who willfully uses or authorizes the use of any Government-owned passenger motor vehicle for other than official purposes shall be suspended from duty by the head of the department (including independent establishments, other agencies, wholly owned Government Corporations and the District of Columbia) concerned, without compensation, for not less than one month, and shall be suspended for a longer period or summarily removed from office if circumstances warrant."

(2) Decalcomanias with quotation from Public Law 600, 79th Congress, can be obtained without cost from the General Services Administration, Region 3, Federal Supply Service, Washington 25, D.C.

b. Exemptions from Identification and Display of Decalcomania.

(1) Unlimited Exemptions.

Motor vehicles regularly used for intelligence, investigative, or security purposes, including such vehicles used by the Counter Intelligence Corps and the Criminal Investigation Division of the Department of the Army, the Office of Naval Intelligence of the Department of the Navy, and the Office of Special Investigation of the Department of the Air Force are exempt from the identification and display of decalcomania.

(2) Special Exemptions.

Motor vehicles assigned for use of officials designated by the Secretary of Defense under applicable law shall be exempt from the identification and display of decalcomania.

(3) Additional Exemptions.

(a) Additional exemptions may be authorized when conspicuous identification on a government vehicle would interfere with the purpose for which the vehicle is used. Requests for such exemptions should be forwarded with full justification through command channels to Headquarters USAF, for approval by the Secretary of Defense.

(b) Departments and agencies will maintain a current record of all vehicles exempt from identification provisions and will institute measures to assure that such vehicles are used for official purposes only.

c. Decal For Control of Airborne Traffic.

A decal, sample copy below, will be applied to the dash panel, in easy view of operator, on all vehicles operated on flight lines. These decals will be purchased locally. One known source of supply is National Decalcomania Corp., Philadelphia, Pa., part number 9285NL.

TOWER SIGNALS FOR CONTROL OF AIRDROME TRAFFIC	
STEADY GREEN 	CLEARED TO CROSS
FLASHING GREEN 	CLEARED TO PROCEED & WATCH FOR LIGHTS
STEADY RED 	STOP
FLASHING RED 	CLEAR ACTIVE RUNWAY
FLASHING WHITE 	RETURN TO STARTING POINT
RED & GREEN 	GENERAL WARNING EXERCISE EXTREME CAUTION

d. Decal—MPH to KPH.

(1) A decal for converting miles per hour to kilometers per hour will be used on military vehicles operating out of the United States.

(2) Procure locally a gummed waterproof paper and cut two inches long and 1 1/2 inches wide. Make comparison figures from miles per hour to kilometers per hour, as shown in figure 22. Place the decal on the instrument panel, in easy view of the operator.

10. SPECIAL MARKINGS.

Special markings prescribed herein are in addition to vehicle markings described in the preceding paragraphs unless otherwise specified. Refer to Technical Order 37A-1-101 for fuel and oil dispensing hose and nozzle markings.

NOTE

These markings will be applied with strips of locally purchased reflectorized tape. The sizes of the letters will comply with the specifications given in the remaining paragraphs of this technical order.

a. Ambulances.

Field ambulances and other vehicles furnished exclusively to the Medical Service will bear additional special markings, in accordance with specifications prepared by the Surgeon General in conformity with the rules of the Geneva Convention. Metropolitan ambulances and other non-field type vehicles used for ambulances will not have special markings. When the protection afforded by the Geneva agreements is required, the Flag, Red Cross, Geneva Convention, and Ambulance markings can be mounted in a conspicuous location on the vehicles used as ambulances and

which possess no features that rule out protection for such vehicles. In the absence of an approved insignia for Air Force Medical Service, the caduceus should not appear on either the metropolitan ambulance or the field ambulance.

b. Buses—Safety Marking.

All buses will be striped, front and rear, with diagonal safety markings. The extent of these markings will be dependent upon the type and model of the vehicle concerned. These stripes may be applied by using locally purchased reflectorized tape.

(1) Front bumper face plates of body on chassis buses will be marked in alternate four-inch bands of yellow and blue stripes inclined 45 degrees to left and right of the center vertical starting pattern. This procedure will not apply to chrome-plated bumpers. Sufficient space will be allowed on bumpers for application of markings.

(2) The diagonal safety marking pattern will be applied to the rear body panel on chassis buses. This pattern will consist of alternate four-inch stripes of yellow and blue inclined 45 degrees to the right and left of vertical to simulate an inverted letter "V." Dimensions of pattern will be 12 inches high and 45 inches wide. It will be centrally located laterally with the upper edge beginning 12 inches below the lower edge of rear body panel windows.

(3) The design of integral buses furnished by various manufacturers necessitates specific locations for safety markings. Instructions will be furnished for application of safety markings to new buses at the time they are delivered to the USAF. The following procedures will apply to buses currently assigned:

(a) Yellow Coach—Front.

The stripes will be immediately below the windshield extending approximately 22 1/2 inches to the right and left of center. The height will be approximately 12 inches. This pattern will be no longer than the space bounded by the openings for windshield wiper arm shafts and the upper outward corners of ventilator doors. Stripes will be four inches; alternating yellow number 1310, or reflectorized tape, and blue, inclined 45 degrees left and right of vertical and simulating an inverted "V" pattern.

(b) Yellow Coach—Rear.

Diagonal safety marking pattern will be applied to the rear body panel in the space immediately below the screen or grill of the engine door. Dimensions will be 12 inches high and 45 inches wide and centrally located laterally.

(c) Southern Coach—Front.

Apply safety marking pattern in the space immediately above and no wider than the radiator grill and extending to the lower edge of the name

plate, "SOUTHERN." The dimensions of this area are approximately 10 x 45 inches.

(d) Southern Coach—Rear.

Diagonal safety marking pattern will be centrally located laterally on rear luggage compartment doors 12 inches below lower edge of rear body panel windows. Dimensions will be 12 inches high and 45 inches wide.

(e) Front and rear bumpers of these vehicles are either chrome plated or stainless steel. Organizational markings as prescribed by paragraph 6. a., section III, will be applied as follows:

1. Yellow Coach—Front.

Apply markings in the horizontal space between head lamp and fog lamps and below ventilator doors.

2. Yellow Coach—Rear.

Apply markings on the flared lower edge of body immediately above bumper.

3. Southern Coach—Front.

Apply markings in the space immediately below head lamps and equally segregated on either side of radiator grill.

4. Southern Coach—Rear.

Apply markings on body panel immediately below rear luggage doors.

5. These markings will be applied with yellow, number 1310, or with reflectorized tape. Insignia, letters, and numerals will be three inches high.

c. Air Force Civil Air Patrol Vehicles.

A distinctive insignia has been designed for application on vehicles assigned to the Civil Air Patrol. The USAF issue of decalcomania is restricted to assigned USAF vehicles only. Decalcomanias are in the form of two-piece insignias, and they will be forwarded to each Civil Air Patrol Liaison Officer for application. The upper section of the decal, containing the words "AF CAP LIAISON OFFICE," is to be centrally placed below the window on each front door. The lower section, containing the words "UNITED STATES AIR FORCE AUXILIARY," is to be placed at the bottom of the panel and in alignment with the upper section.

d. Recruiting Vehicles.

Markings for Air Force vehicles assigned to recruiting are as follows:

(1) Emblem will be a reflectorized decalcomania, 15 inches in diameter, with colors as specified in paragraph 3, *f.* of Air Force Regulation 11-10.

(2) The emblem will be centered horizontally six inches below the top of the door panel (see figure 20) on all vehicles except 1955 Ford station wagons. Place emblem on these vehicles as shown in figure 21.

(3) Gothic type letters 1 3/4 inches high, will be used for the registration number.

(4) The legend "FOR OFFICIAL USE ONLY" will be placed two inches below the lower edge of registration number and will be centered along horizontal lines. Gothic type letters one inch high will be used.

(5) Rear of recruiting vehicles will be marked with the following:

- (a) U. S. AIR FORCE
- (b) RECRUITING SERVICE
- (c) REGISTRATION NUMBER

(6) Rear lettering will be placed so as not to be exposed to abrasive action through vehicle operation and so that vehicle may be identified easily from the rear.

(7) Decalcomanias (see figure 19) will be centrally procured by 3500th USAF Recruiting Wing and will conform with specification MIL-D-8634 (ASG), dated 20 August 1953. Decalcomanias will be obtained from Headquarters, 3500th USAF Recruiting Wing, ATTN: Director of Materiel.

e. Markings for Air Force Vehicles Assigned to Ground Observer Corps.

(1) Emblems will be centered horizontally a distance of six inches below top of left and right door panel and on rear drop panels of carryalls or station wagons.

(2) Registration number will be added just below "AIR DEFENSE COMMAND." The registration number will be of the Gothic type and size as outlined in paragraph 3.

(3) The legend "FOR OFFICIAL USE ONLY" will be added immediately below the inscription "Ground Observer Corps." Lettering will be the size and type outlined in paragraph 3.

(4) The rear markings will be as previously outlined in this technical order.

f. Vehicles Traversing Airfields.

Vehicles which are not ordinarily used on landing areas, runways, taxiways, or peripheral roads

of airfields will be identified whenever their operation is such that they must travel over any part of the landing area. This identification will be accomplished by means of a flag on a staff attached to and flying above the vehicle. This flag shall be not less than three feet square, consisting of a checkered pattern of international orange-and-white squares of not less than one foot on each side.

(1) Flags varying from specified dimensions by not more than 10 per cent are considered to meet requirements.

(2) For camouflage purposes, overseas commanders may deviate from specified colors.

(3) Communications and Ground Control Approach Vehicles.

Bodies of van type vehicles containing communications and ground control approach equipment and located or operated on landing areas, runways, and taxiways will be painted with the conventional "checkerboard" marking on alternate blocks of yellow and white. This pattern of marking will be applied to the antenna housing, roof, sides, rear, and frontal area which is unobstructed by the cab. The size of the blocks will be such that there will be not less than four nor more than six longitudinal rows. Chassis and cabs will be painted yellow, number 1320, until present stocks are exhausted, then use color number 1310.

g. Tractors, other than truck-tractors and aircraft towing tractors, should be marked, using figure 24 as a guide.

h. Tire Inflation Pressures.

(1) The correct operating tire pressures will be marked on the left front pillar post between the upper and lower door hinges of vehicles so equipped. On other type vehicles, the operating tire pressures will be marked on the shields, panels, and frames, immediately adjacent to the tires.

(2) Size of letters will be 1/2 inch high, and they will be of the applicable color, as indicated in paragraph 1, *f.*, section III. Abbreviate the words "tire pressure." EXAMPLE: T. P. 70.

i. School Bus Safety Markings.

The variation in state law requirements for special markings for specific types of vehicles prohibits the establishment of uniform instructions for this class of markings in detailed form. Safety markings for school buses will be applied to conform to local state regulations. Distinctive colors may be applied to the complete vehicle when required by state regulation. Where state laws do not prescribe school bus safety markings, the provisions of section III, paragraph 9, *a.*(2), will be considered minimum requirements.

j. Fuel Dispensing and Aircraft Servicing Vehicles.

Special markings are required on fuel and oil servicing trucks and trailers to minimize the possibility of replenishing aircraft fuel or oil systems with an improper grade of fuel or oil. Precautionary markings are also required to provide sufficient warnings on these vehicles to indicate the safe handling of flammable liquids. Markings for nitric acid servicing semitrailer, type B-1, and fuel servicing semitrailer, types F-6 and F-7, will be applied in a manner as near as possible to that prescribed for comparable vehicles. The same procedures will also apply to all newly standardized fuel, oil, and acid dispensing vehicles procured in the future. The following instructions are furnished for applications of markings to fuel dispensing vehicles as indicated.

(1) No Smoking Within Fifty Feet.

(a) Adjacent to rear of tank body on each side of a semitrailer and on the front tank, apply a strip of red reflectorized tape 10 inches wide with "NO SMOKING WITHIN 50 FT" in four-inch silver letters. Refer to figures 14A and 14C.

(b) Refer to figure 14D for instructions for application of markings on fuel or oil servicing trucks.

(c) On each side of trailers, types A-1, A-1A, and A-3, adjacent to front of tank body, establish points at four and nine inches below tank center line. Through each point, draw a line parallel to longitudinal axis of tank. Apply a red strip of reflectorized tape 3 1/2 inches wide with "NO SMOKING WITHIN 50 FT" in three-inch-high silver letters.

(2) Flammable.

(a) The panel block with the word "FLAMMABLE" therein will be placed on each side and on the rear doors of pumping compartments on semitrailers, as shown in figures 14A and 14B, by applying a strip of red reflectorized tape five inches wide with "FLAMMABLE" in four-inch-high silver letters.

(b) Apply the warning "FLAMMABLE" on rear of tanks on fuel servicing trucks and two-wheel trailers as indicated in figures 14B and 14E. Use four-inch-high letters.

(3) Fluid Identification.

(a) Place "GASOLINE _____ GRADE," or "OIL _____ GRADE," whichever is applicable, on each side of tank. A space of three inches will be provided between this identification and "U.S. AIR FORCE." Markings will be of reflectorized tape, red background with silver letters. Use six-inch letters on semitrailers, four-inch letters on servicing trucks, and three-inch letters on two-wheel trailers.

(b) Numerals identify the grade of gas-

oline or oil will be added in the space preceding the word "GRADE" in sizes prescribed for letters in the preceding paragraph.

(c) Refer to figure 14B for instructions for marking "GASOLINE" on the rear of all semitrailers.

(d) When converting a refueling unit from one type fuel to a different type fuel, all markings will be changed to correspond with the fuel to be dispensed. Example: When converting a unit transporting gasoline to transport JP-4 fuel, remove the fluid identification markings and the service point markings and substitute the applicable JP-4 markings. See paragraph 10.j.(12) for the service point markings.

(e) Water-Alcohol servicing vehicles, such as the MD-3, will have a solid black, color number 1775, chevron (North Atlantic Treaty Organization symbol) the size indicated in the following example, applied with reflectorized tape above the hose reel compartment door and in a conspicuous location on each side of the hose reel compartment, using figures 14H and 14I as guides. Immediately below the chevron, tape "WATER-ALCOHOL" and the NATO code, using legible size letters.

EXAMPLE:

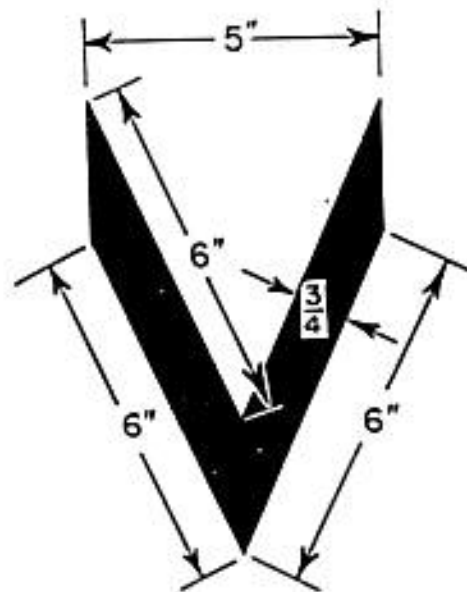

WATER-ALCOHOL
NATO CODE NO. S-738

(f) Water-Alcohol servicing vehicles will have the following taped on each manhole cover or adjacent to the cover:

WARNING: TRANSFER FROM LINE OR CONTAINER IDENTIFIED BY NAME OF ALCOHOL REQUIRED. REFER TO TECHNICAL ORDERS 2-1-14 AND 36A9-3-12-1 FOR WATER-ALCOHOL MIXING AND TESTING DATA.

(g) If jet propelled aircraft engine fuel having a different grade should become available, the marking as referenced in the preceding paragraph is applicable for use on vehicles involved, except for replacing the numeral "4" with the appropriate type number.

(4) Fluid Identification for Nitric Acid Servicing Semitrailer, Type B-1.

Using reflectorized tape, mark the words "FUMING NITRIC ACID" in 10-inch letters on each side of acid tank. A space of three inches will be provided between this identification and the base line for "U.S. AIR FORCE."

(5) Vent Valve Markings.

(a) Refer to figures 14B, 14D, and 14I for instructions for placing the marking "OPEN MAN-HOLE COVERS WHEN PUMPING FUEL OR OIL AT TEMPERATURES BELOW 25°F," on semitrailers and trucks. This marking is not to be applied to nitric acid servicing semitrailers.

(b) Adjacent to rear head of tank on right side of two-wheel trailers, establish points at three, six, and nine inches below tank center line. Draw a line through each point parallel to longitudinal axis of tank. Apply the marking as indicated in the preceding paragraph in two-inch letters.

(6) Tank Capacity.

If available and properly certified, the tank compartment capacity in gallons will be added in two-inch numerals on right side of tank adjacent to man-hole cover.

(7) Inspection Date Record.

(a) Refer to figures 14A and 14D for instructions on applying the "INSPECTION DATE RECORDS" on semitrailers, types F-1A and F-2A, and fuel or oil servicing trucks.

(b) On each side of fuel servicing semitrailers, types F-1 and F-2, the inspection record will be marked on the side compartment door which is adjacent to front end of trailer.

(c) Place the "INSPECTION DATE RECORD" on rear head of tank on two-wheel trailers and on the front of trailer body of gasoline dispensing unit, type D-2. The marking "LINE STRAINERS CLEANED" and all references to inspection of suction hose will be deleted from the inspection record for fuel servicing trailers, type A-3.

(d) When segregator is not functioning properly, the using organization will place the marking "SEGREGATOR INOPERATIVE—MANUALLY DRAIN" and the date, as required by Technical Order 37A-1-101, in one-inch letters, directly below or to the right of "INSPECTION RECORD." After the

segregator is again operative, this particular marking will be removed.

(8) Caution: Air Brakes.

On rear bumper of semitrailers, place the marking "CAUTION: AIR BRAKES" in two-inch letters in the position indicated in figure 14B.

(9) Caution: Nitric Acid.

On left compartment doors of nitric acid servicing semitrailers place the following markings:

(a) On top line, one inch below top edge of doors, mark "CAUTION" in four-inch letters.

(b) On bottom line place "FUMING NITRIC ACID" below the word "CAUTION" in four-inch letters, allowing 1 1/2 inches between lines.

(10) Deicing-Decontaminating servicing vehicles, such as the MB-3, will have a black, color number 1775, triangle (NATO symbol), the size indicated below, applied with reflectorized tape, in a conspicuous location on each side and on the rear of the equipment, using figures 14F and 14G as guides. Immediately below the symbol, either stencil or tape the words "DEICING-DECONTAMINATING" and the NATO code, using legible size letters.

EXAMPLE:

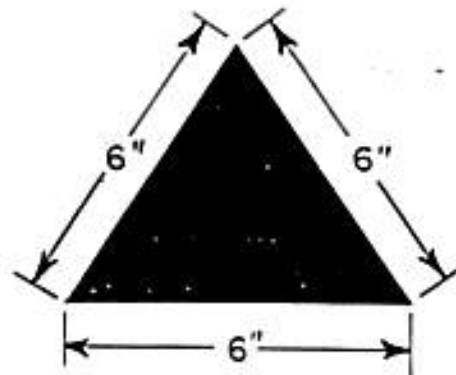

DEICING-DECONTAMINATING
NATO CODE NO. 742 (DEICING)

(11) Deicing-Decontaminating vehicles will have the following phrase stenciled adjacent to each deicing, defrosting fluid filler point: "WARNING—WHEN FLUID HEATER IS OPERATED, USE DEICING FLUID, FSN 6850-558-1248. REFER TO T.O. 42C-1-2 ON DEICING FLUIDS."

(12) Service Point Markings. These markings provide additional fluid identification to prevent improper fuel from being serviced into aircraft. They consist of the following:

etc.

(a) Type Fuel: JP-4, JP-5, AVGS 100/130,

(b) Fuel Symbols.

◆ 1. A filled, four-pointed, black star represents jet fuel or gasoline.

2. A filled, four-pointed black star in a filled black crescent represents rocket fuel. ◆

3. A filled black square ■ represents lubricating oil.

(c) Fuel Code Number. Refer to Technical Order 42B-1-9 for these numbers. Example: The code number for JP-4 fuel is F-40.

(13) Application and Size of Service Point Markings. These markings will be applied to all fuel and oil servicing dispensing nozzles and manhole covers, either with reflectorized tape or by stenciling.

(a) Fuel Dispensing Nozzles. In order for the markings to be visible at different angles, the markings will be placed on the nozzle a minimum of three times. Approximately 1/2-inch letters, numbers, and symbols will be used for marking the nozzles. When applying the markings with reflectorized tape, a silver strip approximately six inches long and two inches wide with black letters, numbers, and symbols will be used. When stenciling the markings, use enamel, black, color number 515 (MIL-E-7729).

NOTE

When stenciling on black surfaces, such as on the type D-1 nozzle, the area to be stencilled will be painted white, color number 1755 (MIL-E-7729), and will be allowed sufficient time to dry thoroughly prior to stenciling on the markings.

(b) Manhole Covers. When applying reflectorized markings to manhole covers, strips of tape as described in the preceding paragraph for use on nozzles may be used. When stenciling these markings, use approximately one-inch letters, numbers, and symbols. These markings will be stencilled on the manhole covers, with enamel, black, color number 515 (MIL-E-7729).

(14) Locations of Service Point Markings.

(a) Over-wing nozzles, 1 1/4 inch to 2 1/2 inch size, type fuel, symbol and code will be taped or stencilled, encircling the body housing directly opposite the handle grip, as in the following example:



Service Point Markings—Over-Wing Nozzle

(b) On type D-1 single point nozzles, the type fuel, symbol, and code will be taped or stencilled to encircle the body or elbow, as in the following example:



Service Point Markings—Type D-1 Nozzle

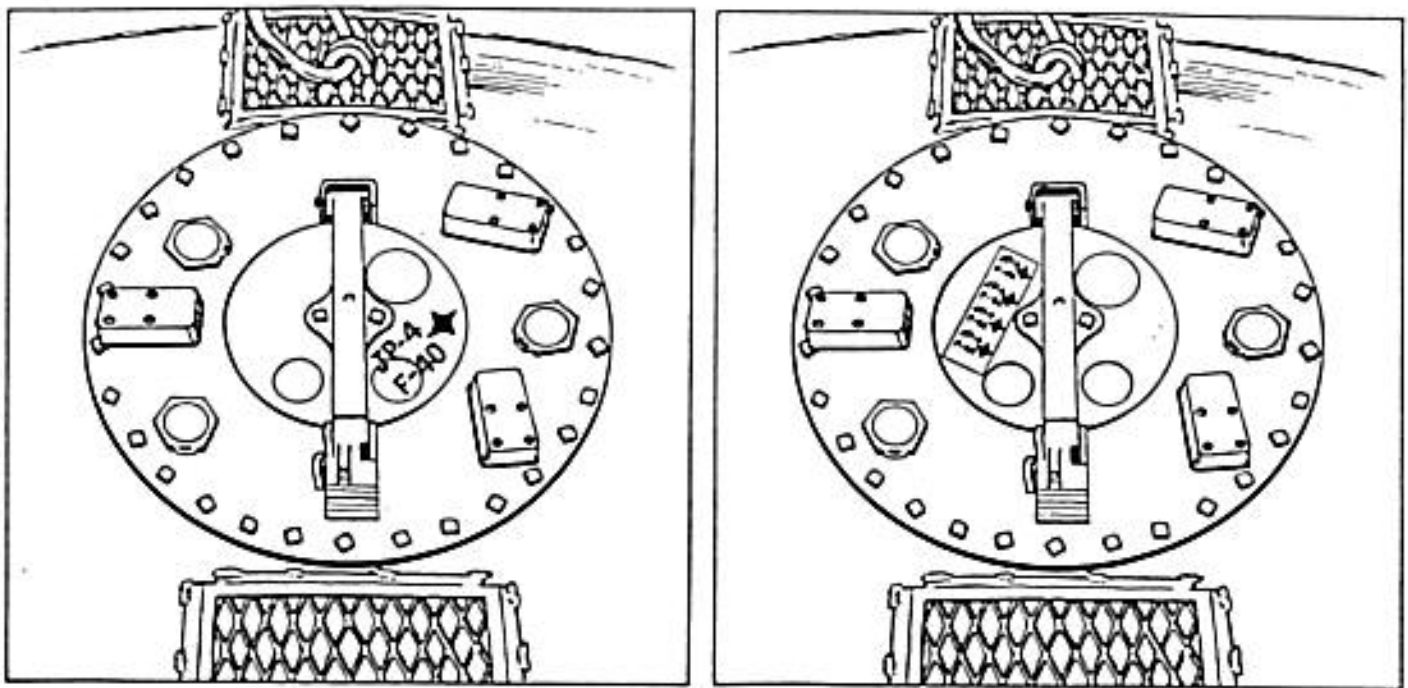

Manhole Cover Markings

(c) On manhole covers, the type fuel, symbol, and code will be taped or stenciled, adjacent to the cover handle or latch, as in the above example.

k. Crash-Fire Vehicles.

The following special markings will be applied to crash-fire and rescue vehicles in order to identify the vehicles properly and to promote familiarity with the different types.

(1) All crash-fire and rescue vehicles designated by an Air Force type will be so identified on the right and left forward sides of the vehicle. The markings will be applied, in accordance with figures 13A, and 13B, using four-inch letters for "U.S. AIR FORCE"; three-inch letters for "REGISTRATION NUMBER"; and one-inch letters for "TYPE VEHICLE."

(2) Crash-fire vehicles which have controls and/or equipment concealed in closed compartments will have the appropriate title marked in a centrally located place on the outside of the compartment doors, as shown in figure 13, using legible size letters.

(3) All fire fighting trucks equipped with radios will have radio call numbers marked on each side, on the top, and on the rear of the vehicles. These numbers will be two feet high and will be put on by using silver reflectorized tape.

1. Operating Instructions.

(1) To aid in the operation and to prevent potential damage to equipment and injury to personnel, vehicles without adequate operational instructions or

"plates" in the driver's or operator's compartment may have the name of, or duty performed by the lever, switch, valve, or pedal, etc., marked on or near each, and the use or direction of movement if deemed necessary. These markings will be of the smallest readily readable size. Understandable abbreviations may be used. On equipment where it is determined that marking instructions will not obtain the desired results because of appearance, inadequate space, or other reasons, an operating instruction plate will be fabricated and fastened securely to the equipment within easy and full vision of the operator or driver.

(2) Cranes (stock number 5050-324165-354 and stock number 5020-270205-518) should be equipped with a metal sign, approximately eight by ten inches, affixed to the upper center of the cab panel directly in front of the operator's knees. This sign should be white background with "DANGER" in two-inch red letters; "DO NOT OPERATE WITHIN 10 FEET OF ELECTRIC LINES" in 1/4-inch black letters; plus a metal plate, approximately three by four inches, affixed at right hand side of the above referenced "DANGER" sign, red background with "DO NOT OPERATE BOOM ABOVE 80° FROM THE HORIZONTAL PLANE" in 5/16-inch silver letters.

(3) All forklifts should have "NO RIDERS" in two-inch black letters, stenciled vertically on both uprights of the fork frame, facing the operator.

(4) Aircraft towing tractors and tugs used for towing aircraft should be equipped with a metal sign, approximately three by four inches, red background with "MAXIMUM SPEED 10 MPH" "AIRCRAFT TOWING SPEED 5 MPH" in 5/16-inch silver letters. This

sign should be attached to a panel directly in front of the operator.

(5) All special purpose and engineer equipment having speedometers and/or tachometers should have the maximum safe operating speed and/or revolutions per minute indicated by a red line painted on the glass covering the dial.

(6) Mobile cranes and street sweepers should have an instructional metal placard, of the largest practical size, affixed to rear; white background with red letters: "SOUND HORN, WAIT FOR SIGNAL FROM OPERATOR BEFORE PASSING."

m. Continental or Lycoming Air-Cooled Engines.

All vehicles equipped with Continental or Lycoming air-cooled engines will have the auxiliary engine oil, which is specified in the applicable technical order, either stenciled or taped on a body panel near the engine, or on the access door to the engine, using 1/2-inch letters. When applying this information by stenciling, use white paint on red surfaces and black paint on yellow surfaces. When using tape, apply red tape with silver numbers.

EXAMPLE OF INFORMATION:

- Auxiliary
- Engine
- Oil
- Specifications
- Grade

n. Marking Air Police Vehicles.

(1) Vehicles will be marked when they are assigned to, or upon receipt by, the using organization. Markings will remain on the vehicles as long as they are assigned to an Air Police type organization, military or civilian.

(a) Distinctive Marking Specifications.

1. Commercial Type Vehicles.

Commercial type, 1/2-ton, 4x2 carryalls and 1954 and older 1/2-ton, 4x2 pickup trucks will be marked with a strip of silver reflectorized tape five inches wide with three-inch blue letters. Commercial type 1955 and later model station wagons and 4x2 pickup trucks will be marked with a strip of silver reflectorized tape three inches wide, with 2 1/2-inch blue letters.

2. Tactical Type Vehicles.

With the exception of the 1/4-ton, 4x4 utility truck, M38A1, tactical type vehicles assigned to Air Police type organizations will not be distinctively marked. Marking of the M38A1 will consist of a white metal sign five inches wide, three feet long, with 1/2-inch blue border and three-inch, blue, plain, block letters, as illustrated in figure 17B, and

a white disc 16 inches in diameter, with a 1/2-inch blue border and three-inch, blue, copperplate Gothic letters, as illustrated in figure 17C.

(b) Placement of Markings.

1. Distinctive markings on carryalls will be placed as follows:

a. The five-inch silver stripe will begin at the forward edge of the left front door and will encircle the body of the vehicle from left to the right forward edge of right front door. The top of the stripe will be approximately 2 5/8 inches below the lower edge of the window openings (see figures 15D and 15E).

b. The five-inch silver stripe on the front of the carryall will follow the contour of the vehicle across the top of the windshield from the right roof drip moulding to the left roof drip moulding (see figure 15D).

2. Distinctive markings on 1955 through 1957 Ford station wagons will be placed as follows:

a. The three-inch silver stripe will begin at the forward edge of the left front door and will encircle the body of the vehicle to the forward edge of the right front door. Extend the silver stripe to the end of the tail fins on the 1957 Ford station wagon, as shown in figure 15A.

b. The three-inch silver stripe on the front of the station wagon will be placed on the hood, as shown in figure 15B.

NOTE

The white stripe presently on the top of these station wagons will not be relocated on the hood until repainting is required.

c. Mark the rears of station wagons, as shown in figure 15C.

3. Distinctive markings on 1/2-ton, pickup trucks will be placed as follows:

a. On 1955 and later half-ton pickups, the three-inch silver stripe will begin at the forward edge of the left door and circle the cab of the vehicle to the forward edge of the right front door. The top of the stripe will be approximately 1/2 inch below the lower edge of the window opening, using figure 16A as a guideline. The three-inch stripe on the front of these vehicles will be placed on the hood, using figure 16B as a guide. On the rear of the cab on these vehicles, "AIR POLICE" will be applied using a strip of silver reflectorized tape with 2 1/2-inch blue letters, as shown in figure 16C.

NOTE

The white strip presently on the top of these pickups will not be relocated on the hood until repainting is required.

b. On 1954 and older pickup trucks, use a five-inch white stripe. Begin this stripe at the forward edge of the left front door and encircle the cab from the left to the right hinge pillar post, the top of the stripe to be approximately 2 5/8 inches below the lower edge of the window opening (see figures 16A and 16C for guides). On the front of this vehicle, the five-inch white stripe will follow the contour of the vehicle across the top of the windshield from the right roof drip moulding to the left roof drip moulding (see figure 15D). Use a strip of silver reflectorized tape three inches wide with AIR POLICE in 2 1/2-inch blue letters.

4. Distinctive markings on the M38A (jeep) will be placed as follows:

a. The five-inch metal sign will be centered and attached to the lower portion of the windshield frame (see figure 17B).

b. The 16-inch metal disc will be attached to the spare wheel (see figure 17C). The disc and attaching bracket will be locally fabricated in accordance with data provided in figure 18.

5. Lettering will be placed as follows:

a. Front of carryalls, station wagons, and pickups—centered as shown in figures 15B, 15D, and 16B.

b. Sides of carryalls, station wagons, and pickups—as shown in figures 15A, 15D, and 16A.

c. Rear of carryalls, station wagons, and pickups—centered as shown in figures 15C, 15E, and 16C.

d. Front of M38A1 (jeep)—as shown in figure 17B.

e. Sides of M38A1 (jeep)—as shown in figure 17A.

f. Rear of M38A1 (jeep)—as shown in figure 17C.

g. Marking of SAC Alert and Reflex Action Vehicles.

These vehicles will be painted and marked in the same manner as Air Police vehicles, except the legend will be "ALERT FORCE" in lieu of "AIR POLICE" and will be on a yellow background instead of a white or silver one.

11. EXEMPTIONS.

a. Exemption from the requirement to display official U. S. Government tags, shields, and Air Force markings, color, or other identification is granted for those motor vehicles used by the Office of Special Investigation in duties where conspicuous identification

is contrary to the public interest.

b. Vehicles assigned to the Secretary of the Air Force; Under Secretary of the Air Force; Assistant Secretaries of the Air Force; Chief of Staff, USAF; and Vice Chief of Staff, USAF, are exempted from all special markings.

SECTION IV
ILLUSTRATED GUIDE TO VEHICLE MARKINGS

1. FIGURES.

The following figures are representative of the various types of bumpers, cabs, and bodies upon which the vehicle markings specified in this technical order are to be placed. The markings illustrated are furnished as a guide to indicate the location of the markings in respect to the space available. Marking of vehicles not illustrated herein will be applied in a manner as nearly as possible to that illustrated for comparable vehicles.

2. INDEX TO FIGURES.

- Figure 1—Ambulance, Field, 3/4-Ton, 4x4 (Front and Top)
- Figure 2—Ambulance, Field, 3/4-Ton, 4x4 (Side and Rear)
- Figure 3—Ambulance, Field, 3/4-Ton, 4x4, Models KD and M-43
- Figure 4—Bus, Body on Chassis
- Figure 5—Bus, Integral (Front View)
- Figure 6—Bus, Integral (Rear View)
- Figure 7—Front Bumper, Trucks, 1/4- to 1 1/2-Ton
- Figure 8—Front Bumper, Trucks, 1 1/2- to 7 1/2-Ton
- Figure 9—Trucks, 1/4- to 1/2-Ton
- Figure 10—Cabs, 1 1/2- to 2 1/2-Ton
- Figure 11—Trucks, 2 1/2-Ton and Over
- Figure 12—Trailers
- Figure 13—Crash-Fire Vehicles
- Figure 14—Fuel and Oil Servicing and Deicing-Decontaminating Vehicles
- Figure 15—Air Police Carryalls and Station Wagons
- Figure 16—Air Police 1/2-Ton Truck
- Figure 17—Air Police Jeep
- Figure 18—Diagram of Air Police Sign Shown in Figure 17C
- Figure 19—Recruiting Service Decal
- Figure 20—Recruiting Vehicle
- Figure 21—1955 Ford Station Wagon
- Figure 22—Decal, MPH to KPH
- Figure 23—Truck, Forklift
- Figure 24—Tractor, Warehouse

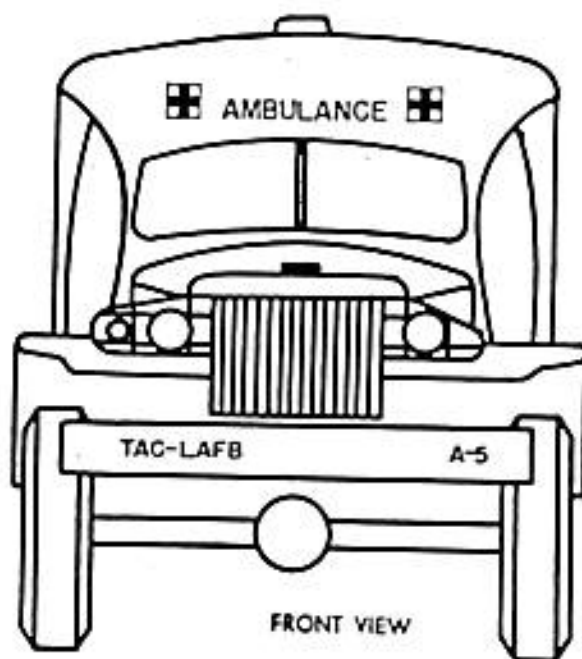

FRONT VIEW

60" x 60" BRIGHT RED CROSS, EACH LIMB TO BE
20" 50. AND CENTERED ON THE SNOW WHITE FIELD

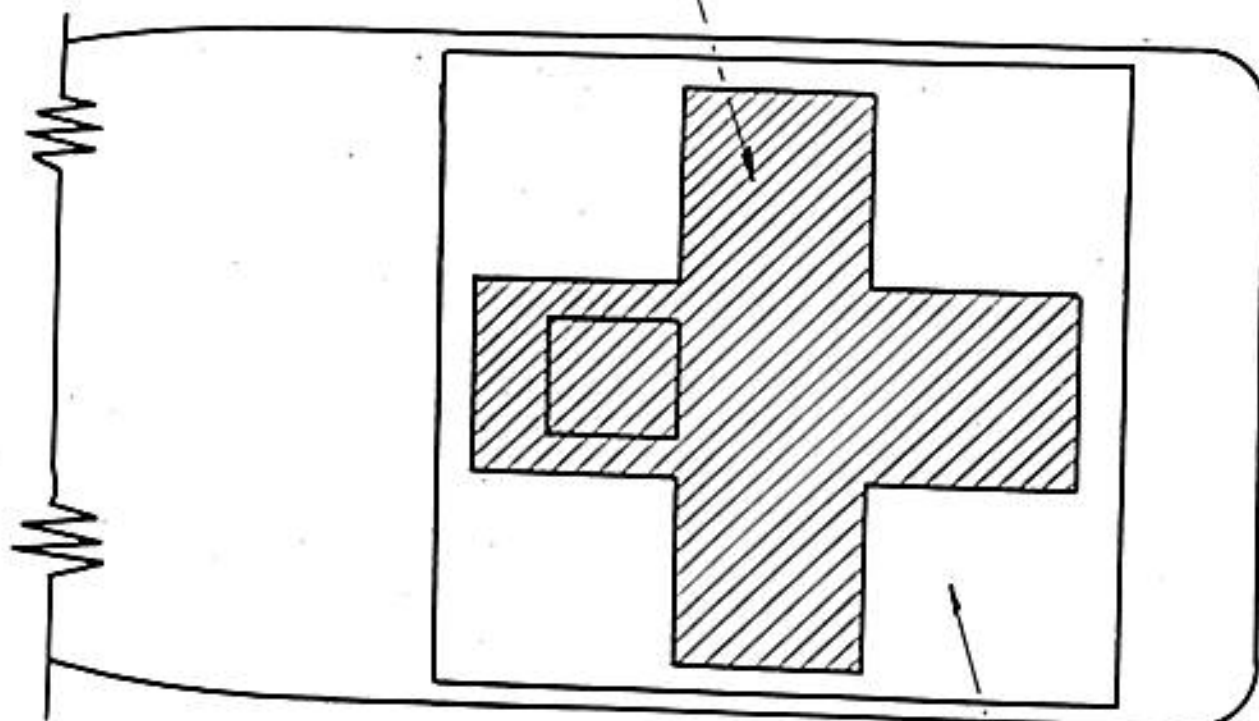

TOP VIEW

64" x 64" SNOW
WHITE FIELD

Figure 1—Ambulance, Field, 3/4-Ton, 4x4 (Front and Top)

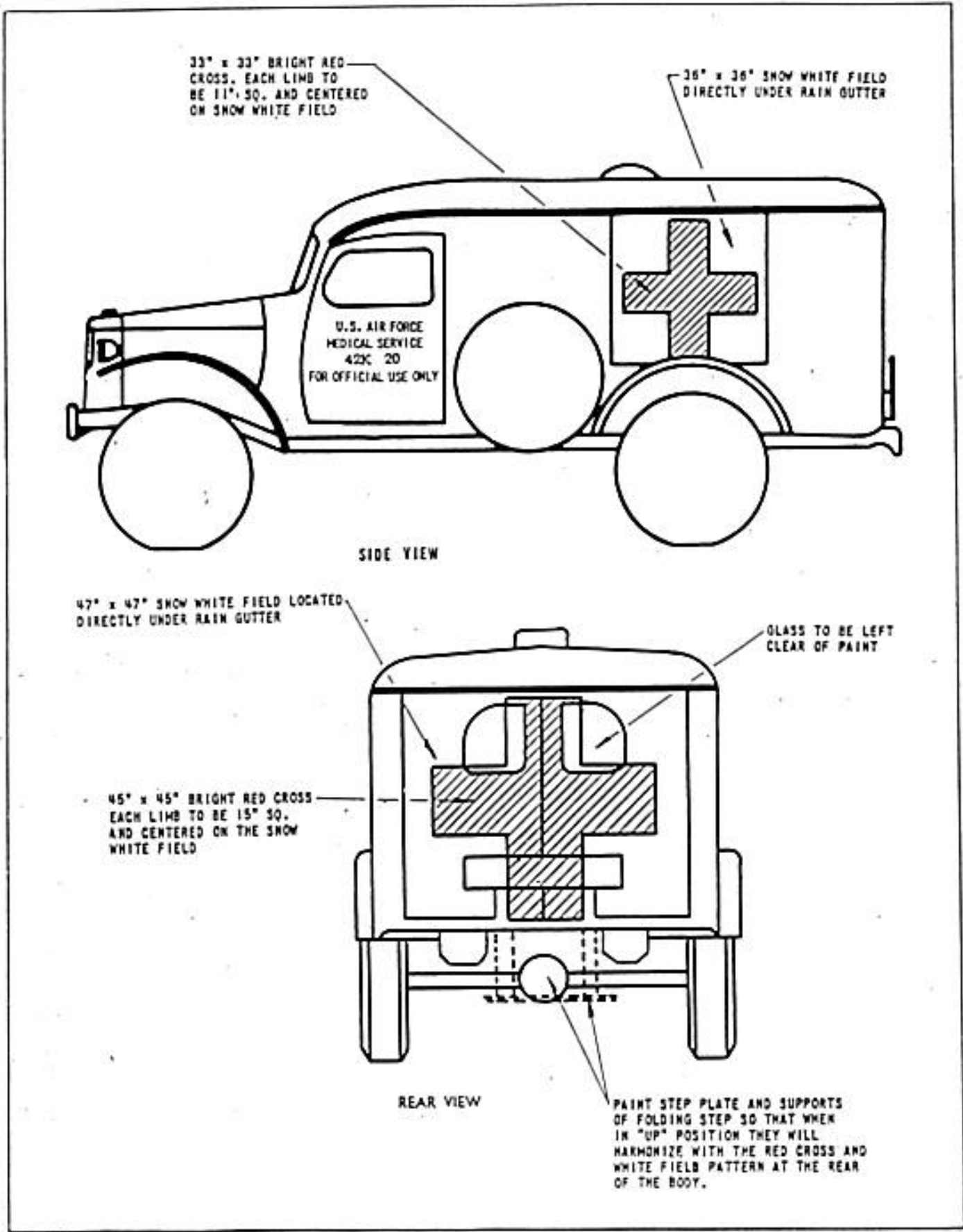

Figure 2—Ambulance, Field, 3/4-Ton, 4x4 (Side and Rear)

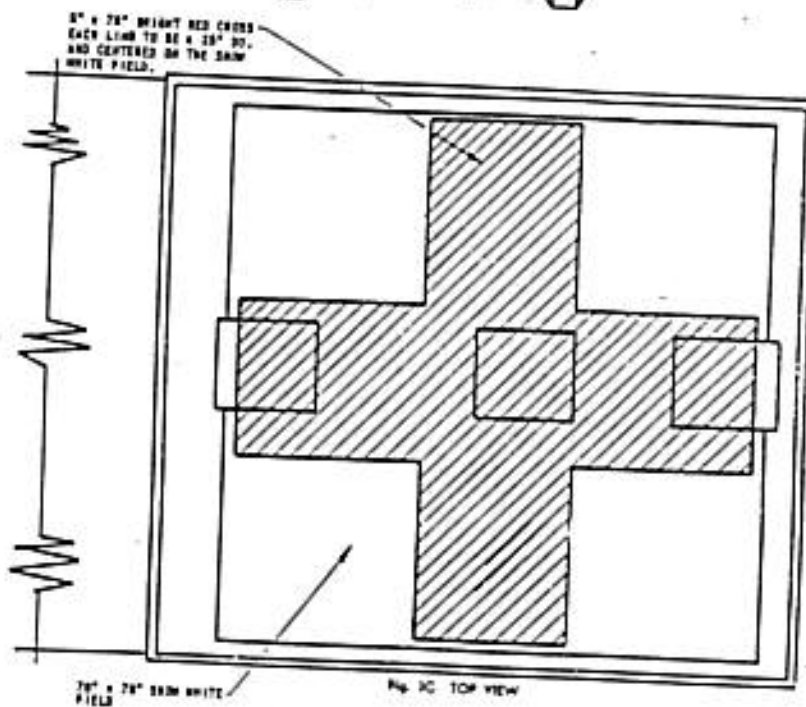
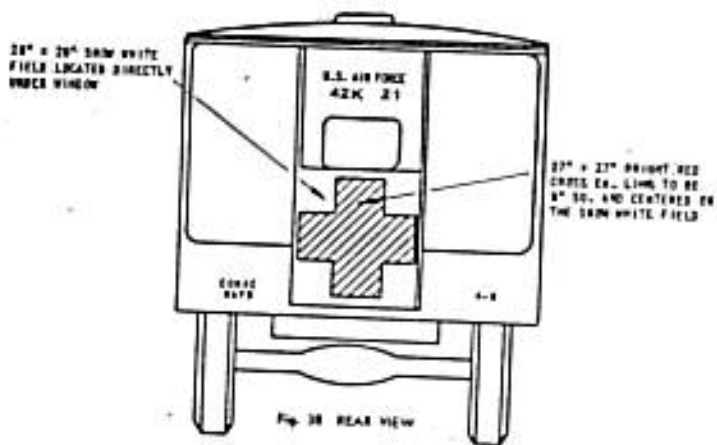
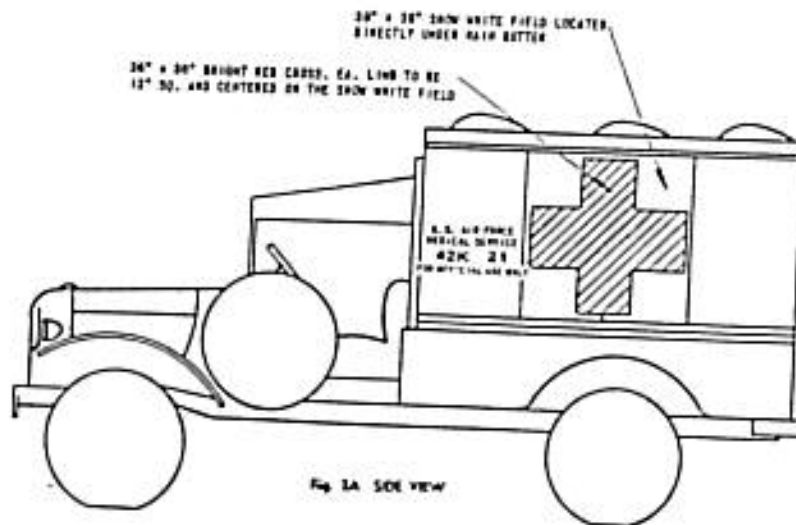

Figure 3—Markings for Ambulance, Field, 3/4-Ton, 4x4, Models KD and M-43

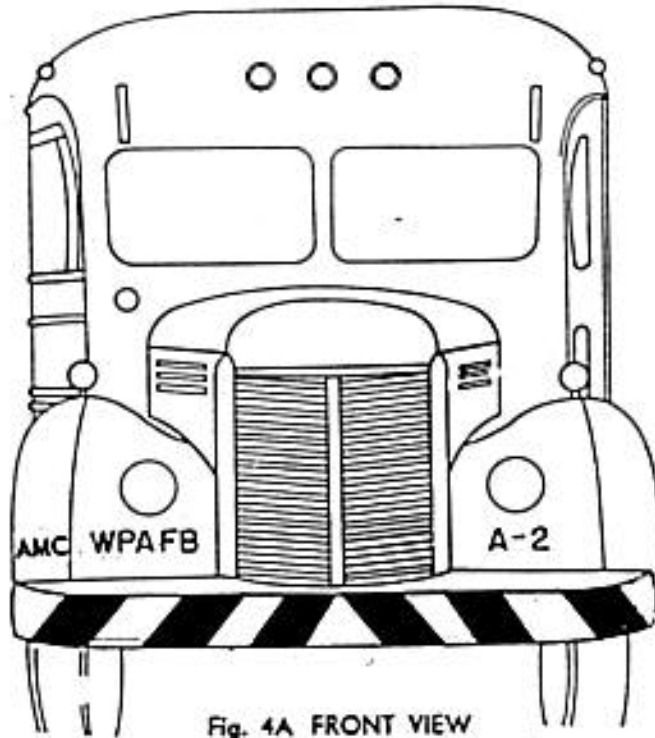

Fig. 4A FRONT VIEW

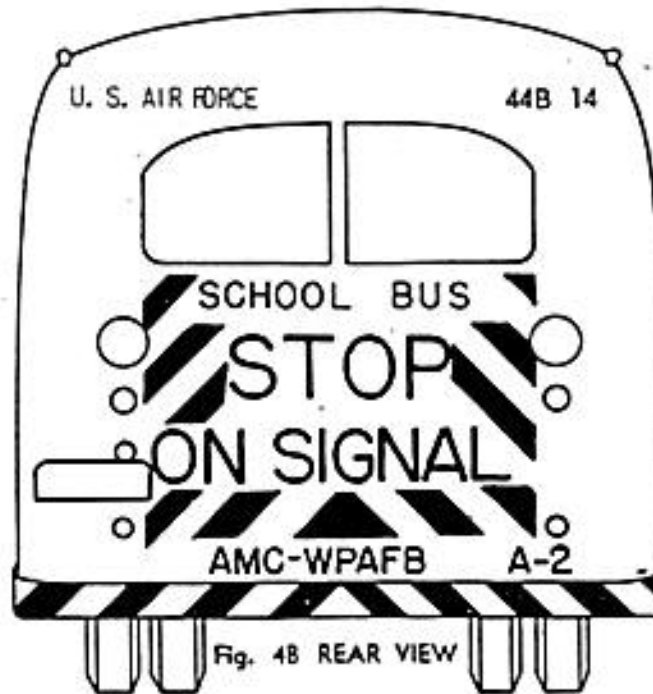

Fig. 4B REAR VIEW

Figure 4 - Bus - Body on Chassis

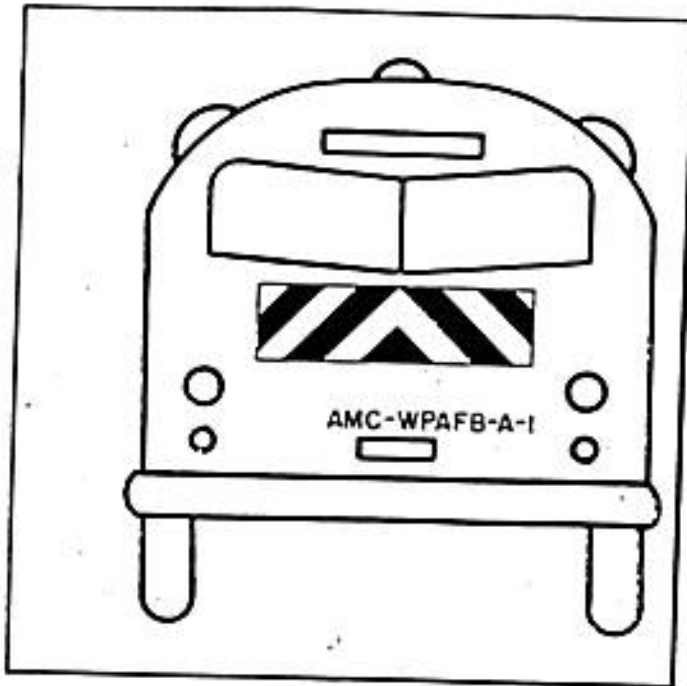

Figure 5—Bus, Integral (Front View)

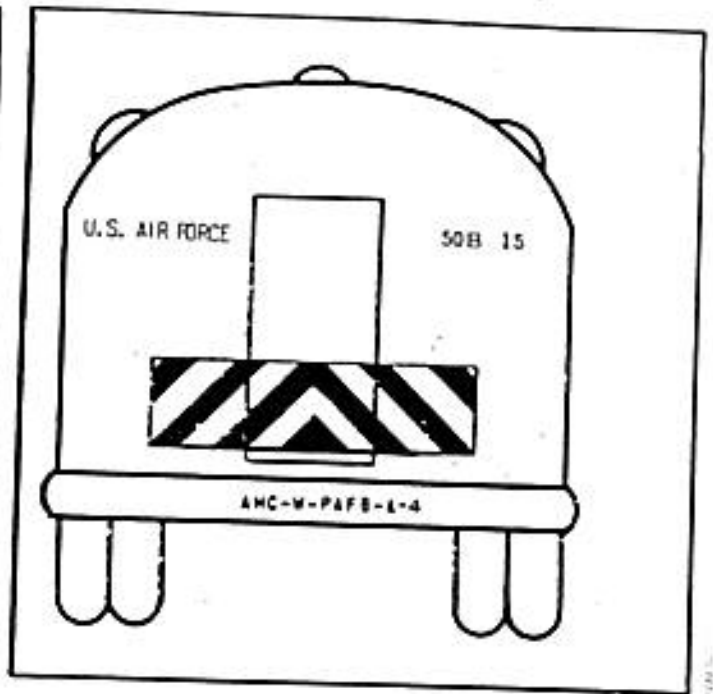

Figure 6—Bus, Integral (Rear View)

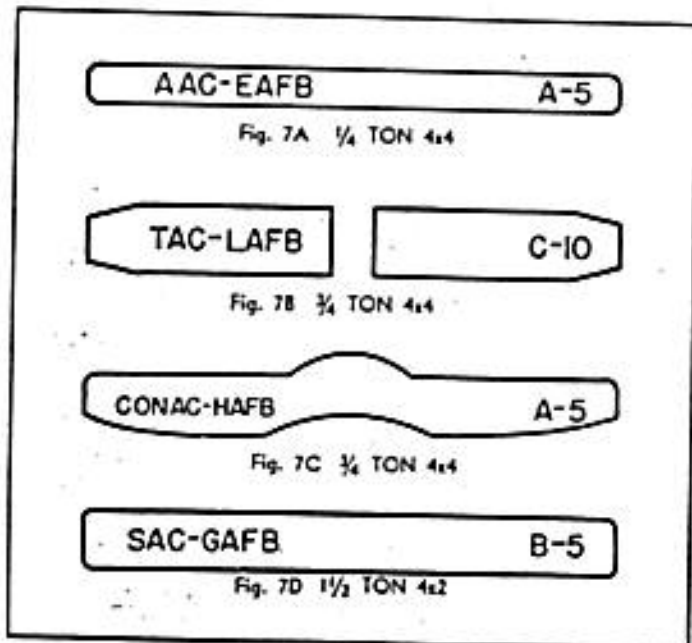

Figure 7—Front Bumper, Trucks, 1/4-to 1 1/2-Ton

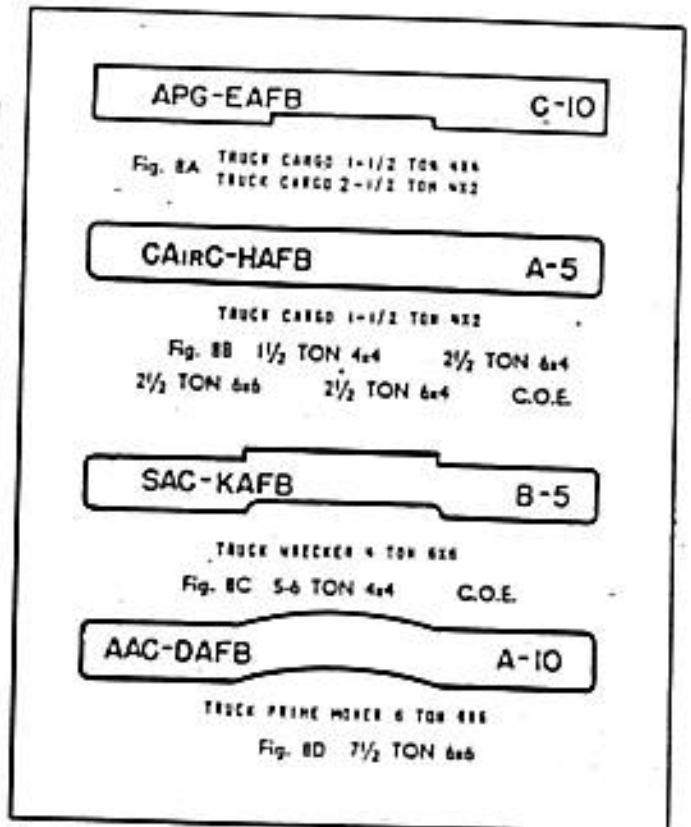

Figure 8—Front Bumper, Trucks, 1 1/2-to 7 1/2-Ton

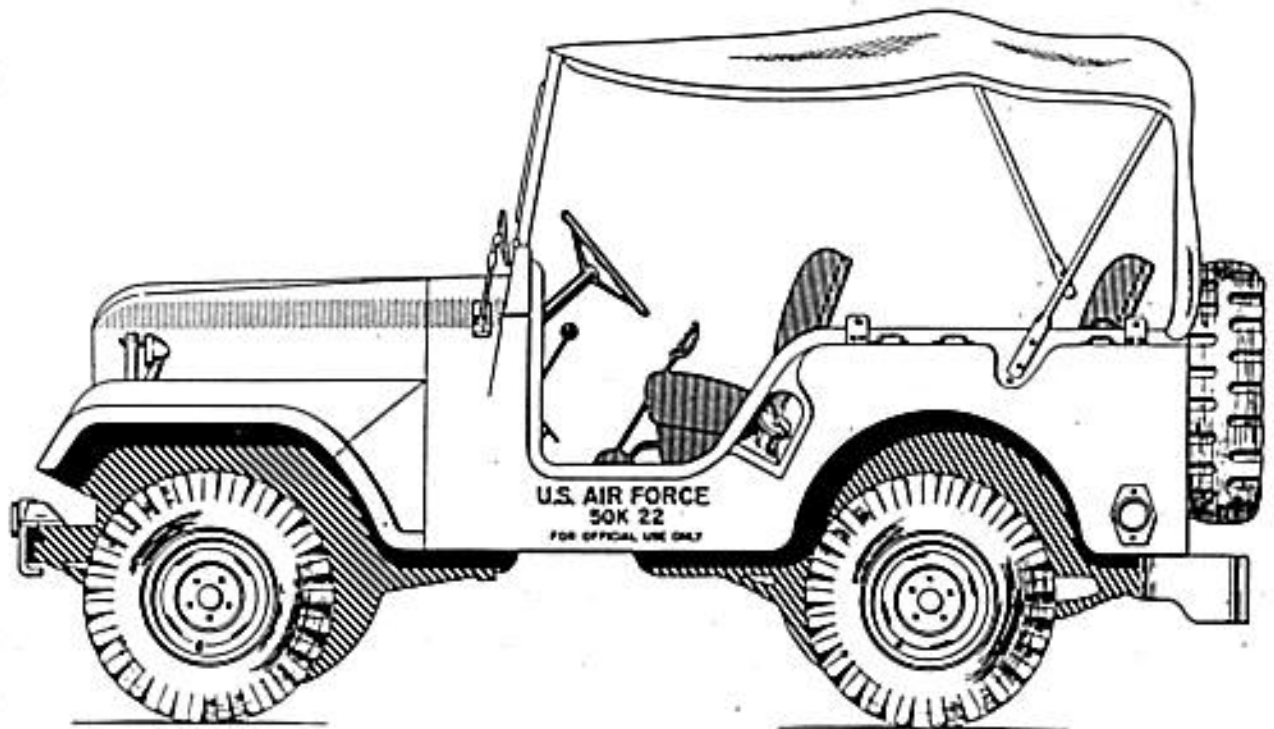

Figure 9A—1/4 Ton 4x4 (Side View)



Figure 9B—1/4 Ton 4x4 (Front View)

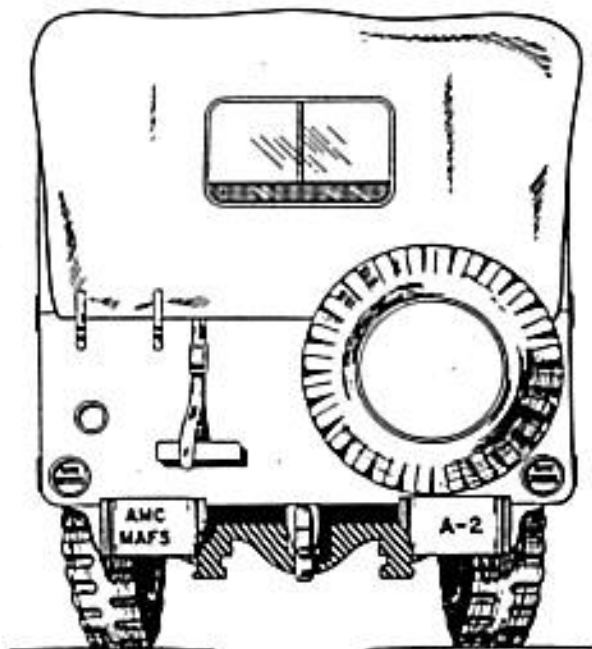

Figure 9C—1/4 Ton 4x4 (Rear View)

Figure 9—Trucks, 1/4- to 1/2-Ton

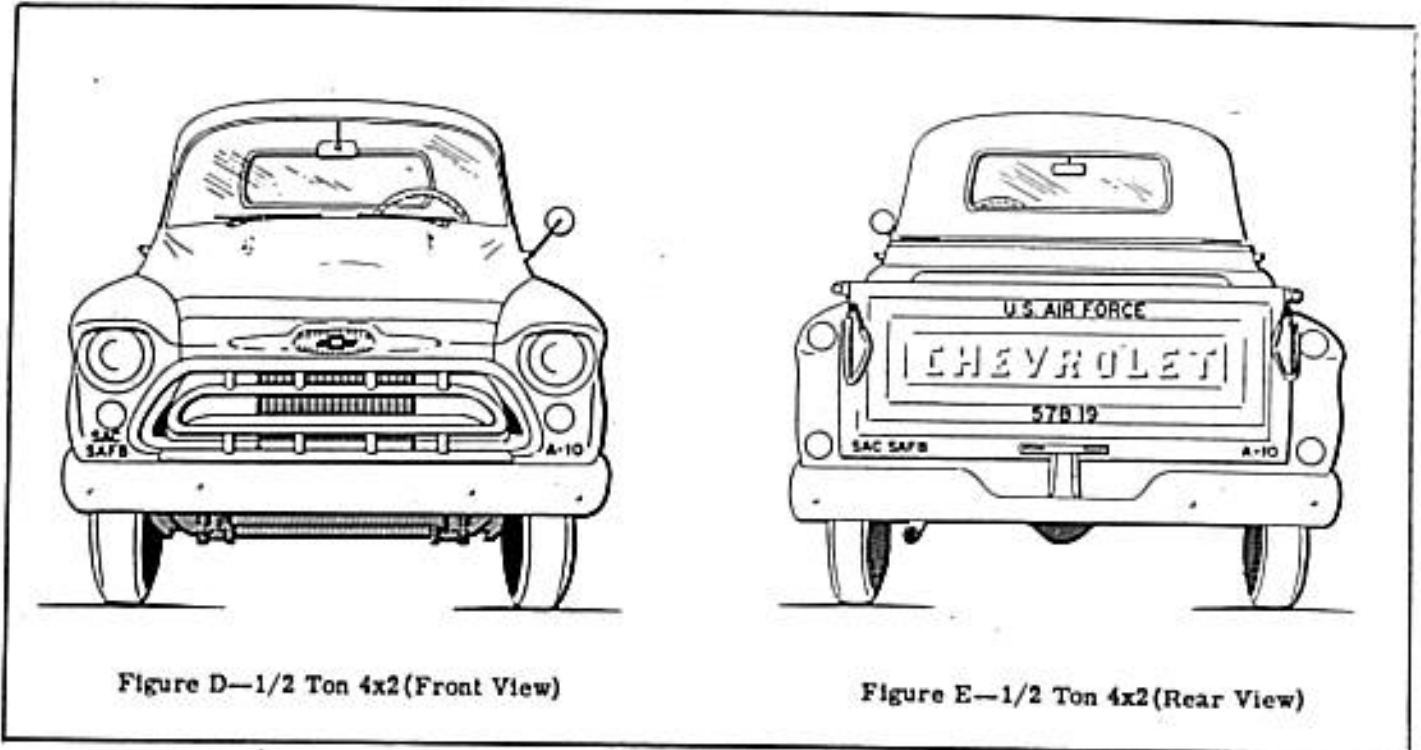

Figure 9—Trucks, 1/4- to 1/2-Ton (Cont'd)

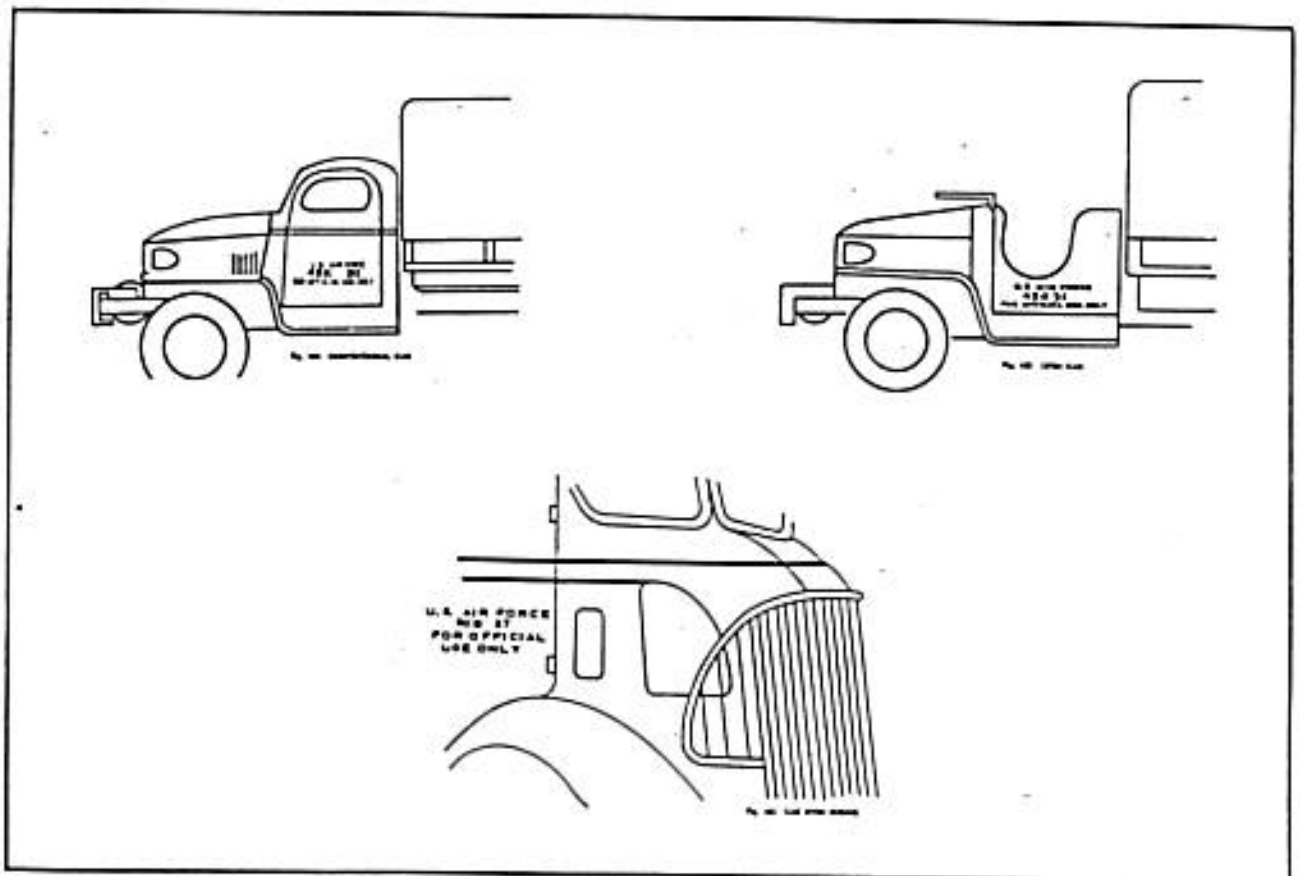

Figure 10—Cabs, 1-1/2-to 2-1/2-Ton

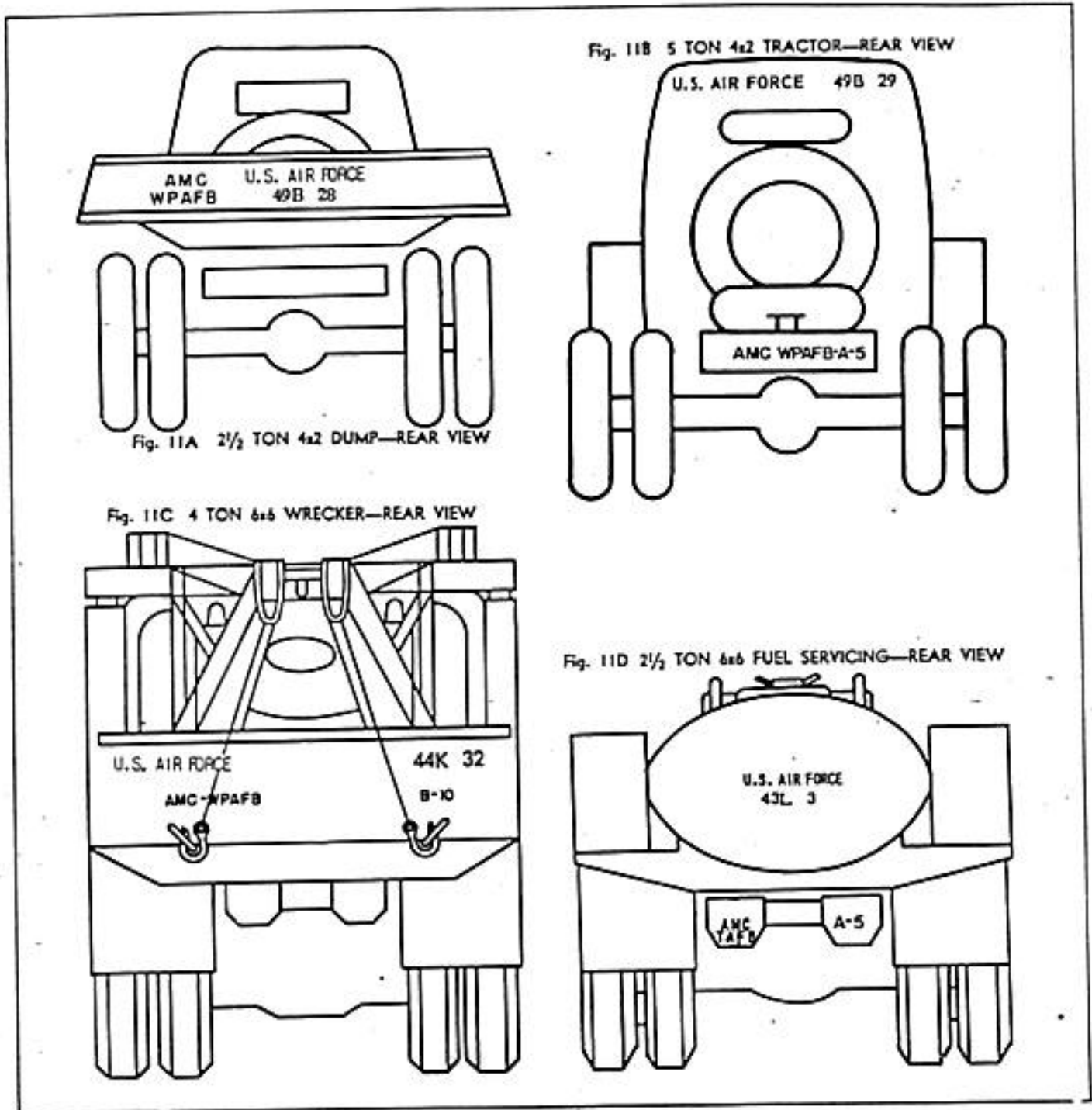

Figure 11—Trucks, 2 1/2-Ton and Over

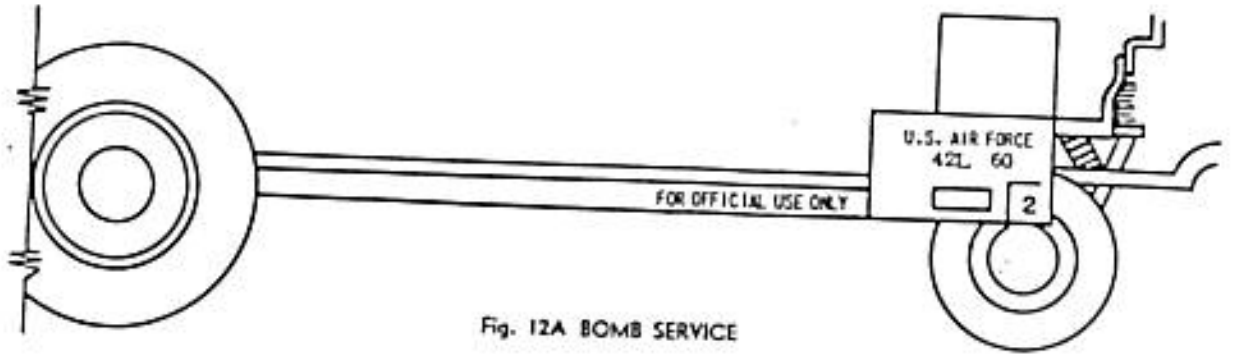

Fig. 12A BOMB SERVICE

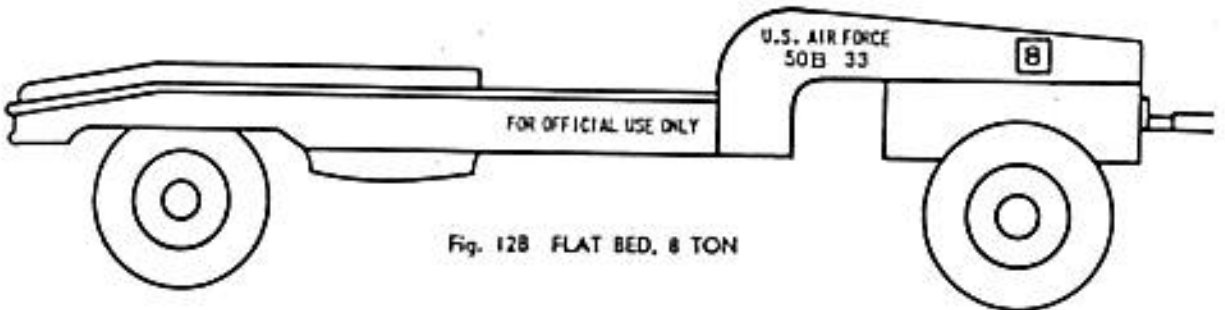

Fig. 12B FLAT BED, 8 TON

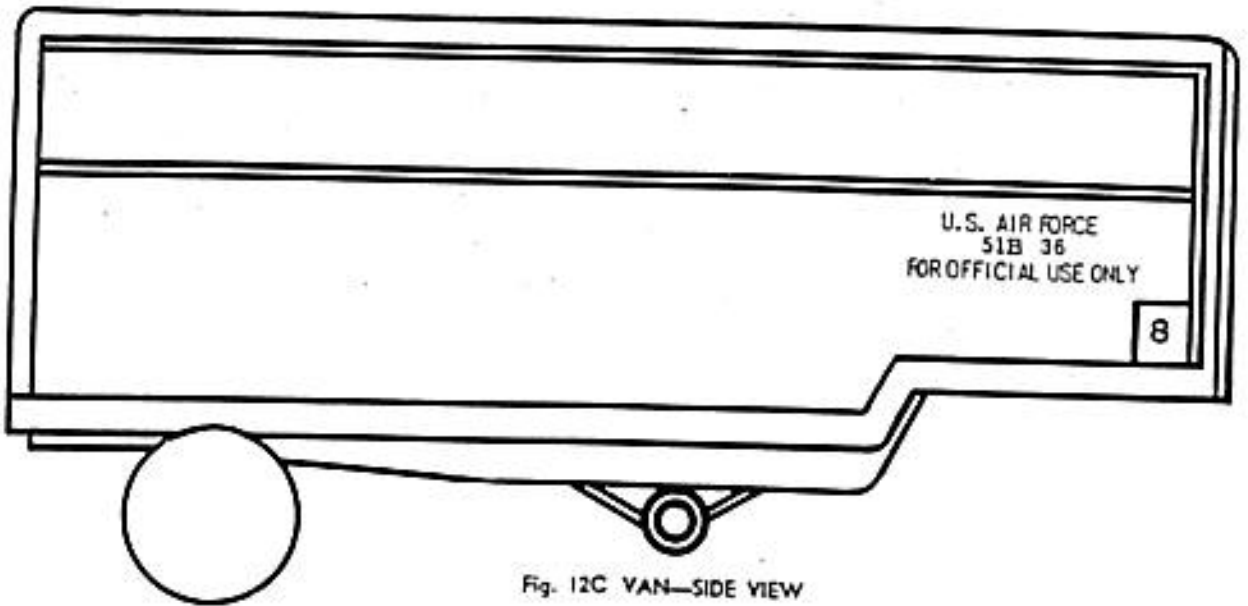

Fig. 12C VAN—SIDE VIEW

Figure 12 - Trailers

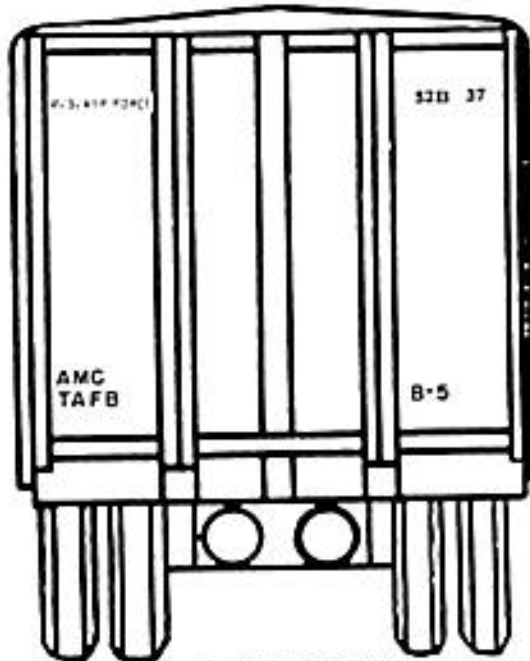

Fig. 12D VAN—REAR VIEW

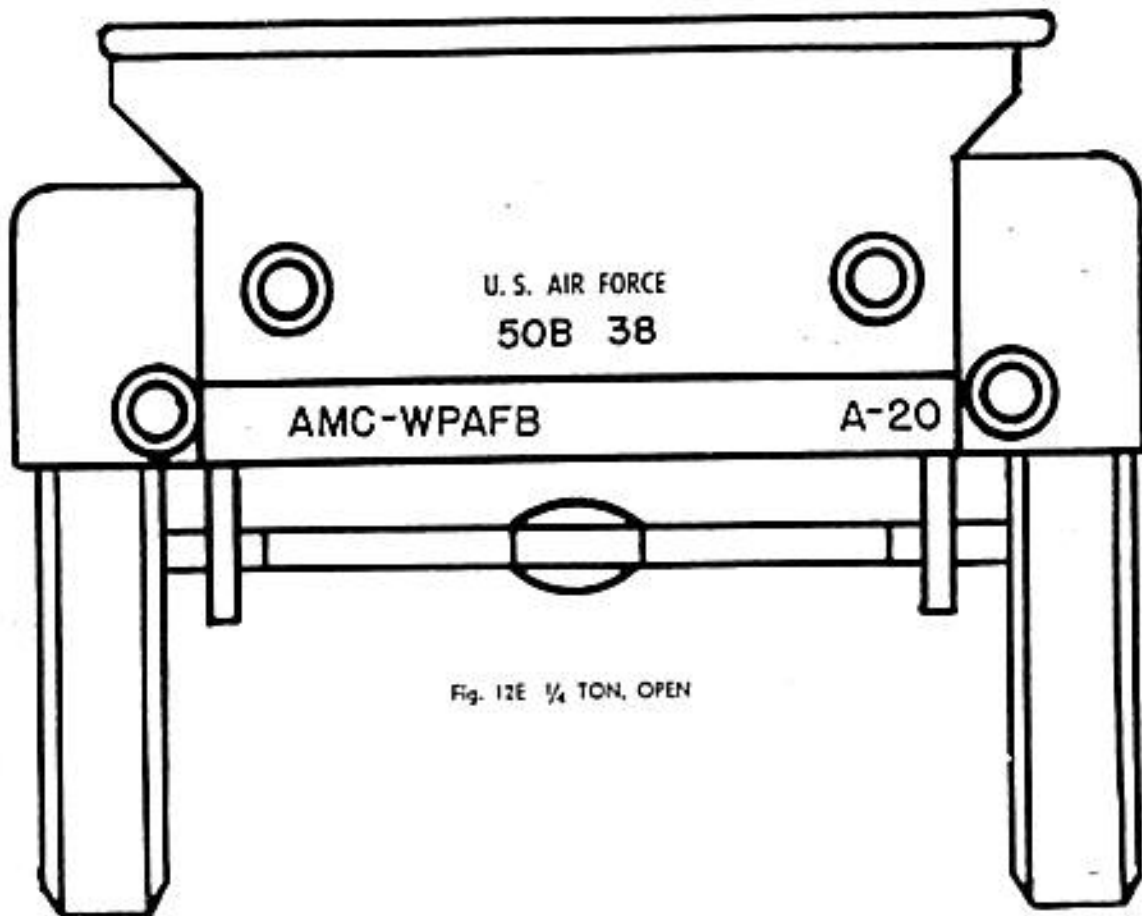

Fig. 12E 1/4 TON, OPEN

Figure 12 - Trailers (Cont)

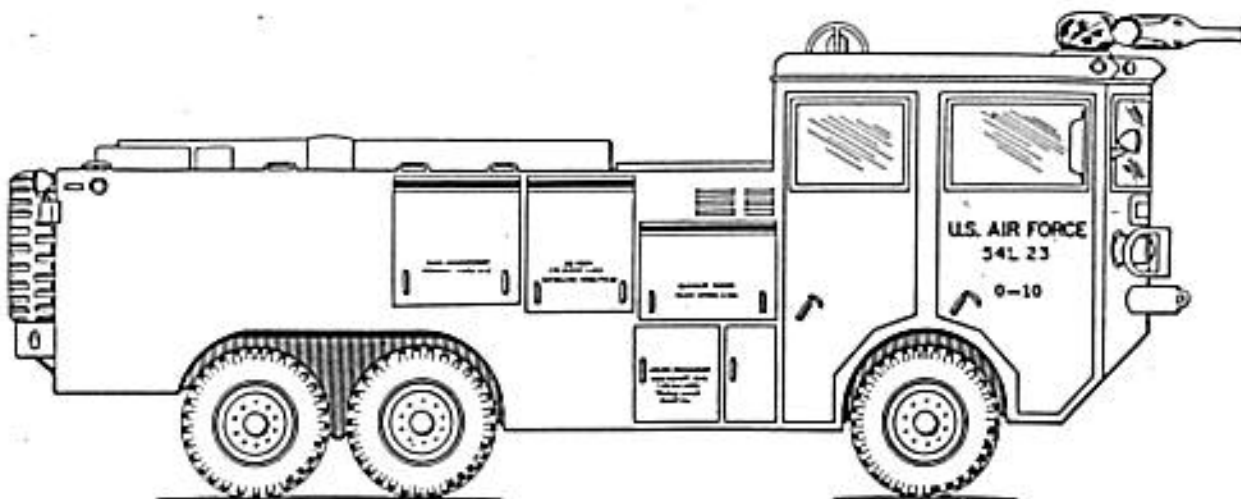

Figure 13A—Truck, Crash, Fire (Side View)

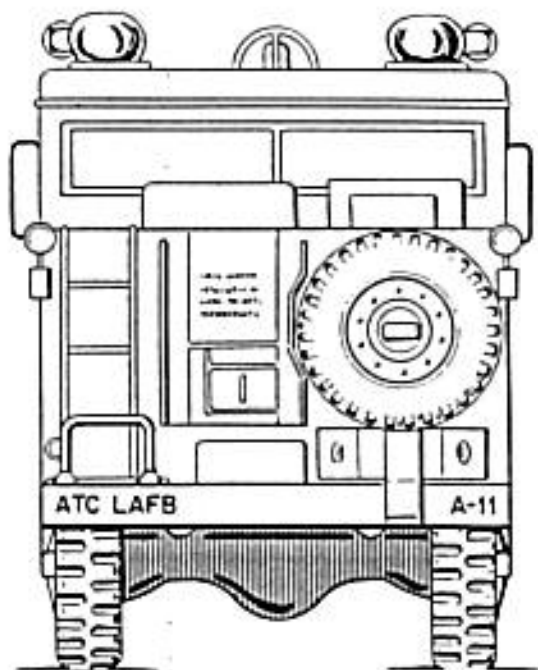

Figure 13B—Truck, Crash, Fire (Rear View)

Figure 13—Crash Fire Vehicles

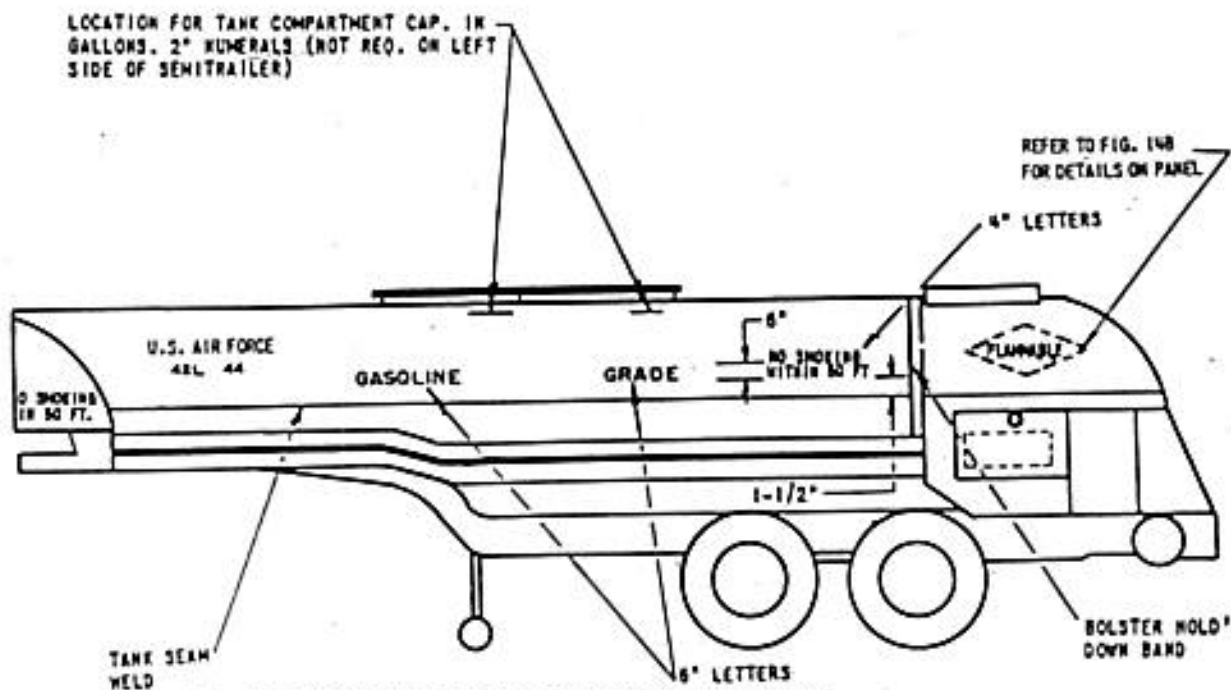

Fig. 14A SIDE MARKINGS OF FUEL SERVICING SEMITRAILER

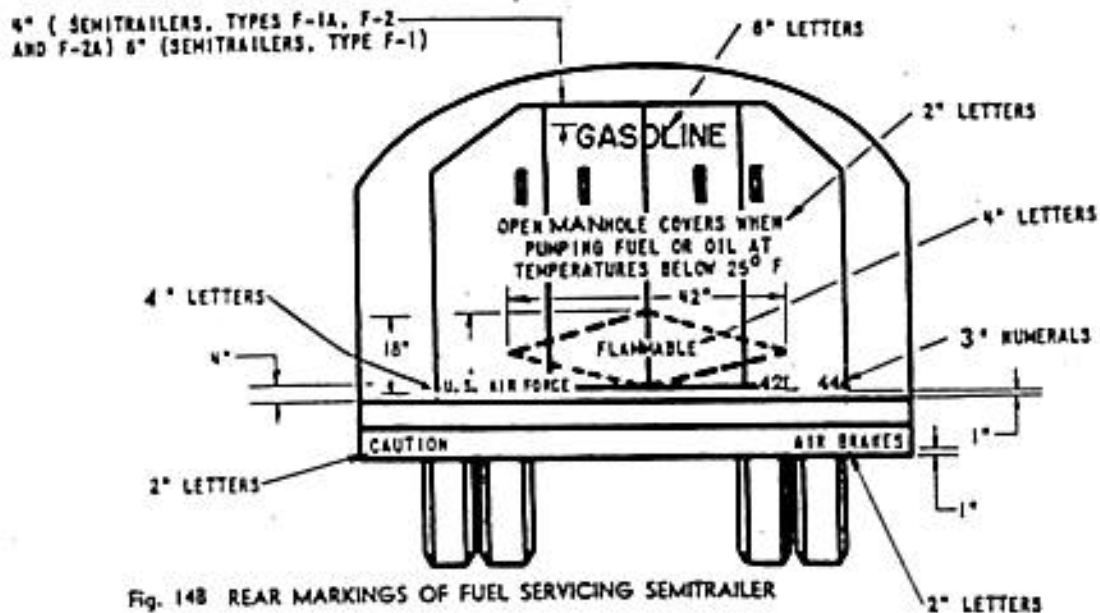

Fig. 14B REAR MARKINGS OF FUEL SERVICING SEMITRAILER

Figure 14—Fuel and Oil Servicing and De-icing-Decontaminating Vehicles

Fig. 14C FRONT MARKINGS OF FUEL SERVICING SEMITRAILER

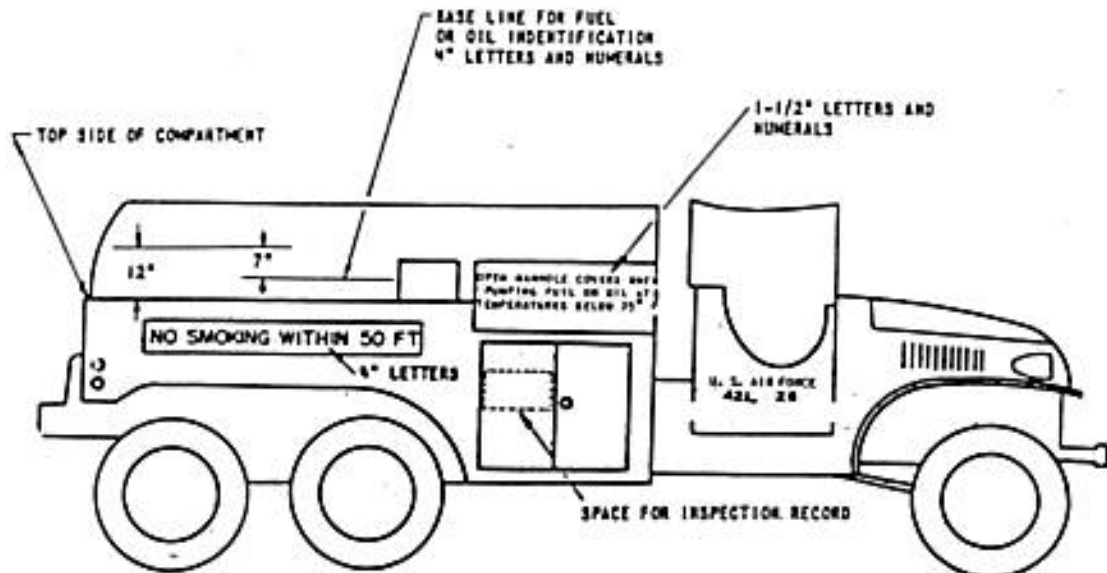
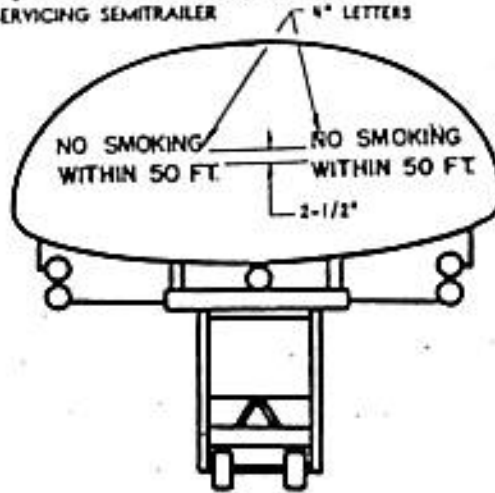

Fig. 14D SIDE MARKINGS OF FUEL OR OIL SERVICING TRUCK

Fig. 14E REAR MARKINGS OF FUEL OR OIL SERVICING TRUCK

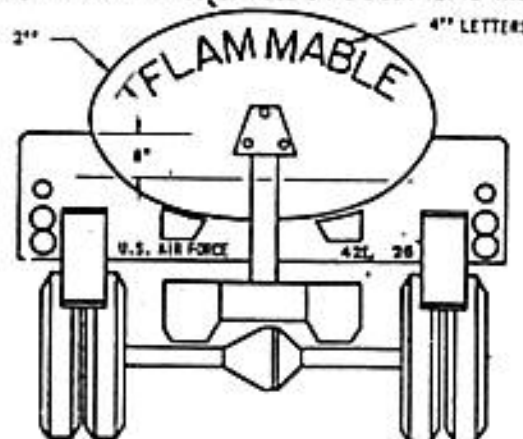

Figure 14—Fuel and Oil Servicing and De-icing-Decontaminating Vehicles (Cont'd)

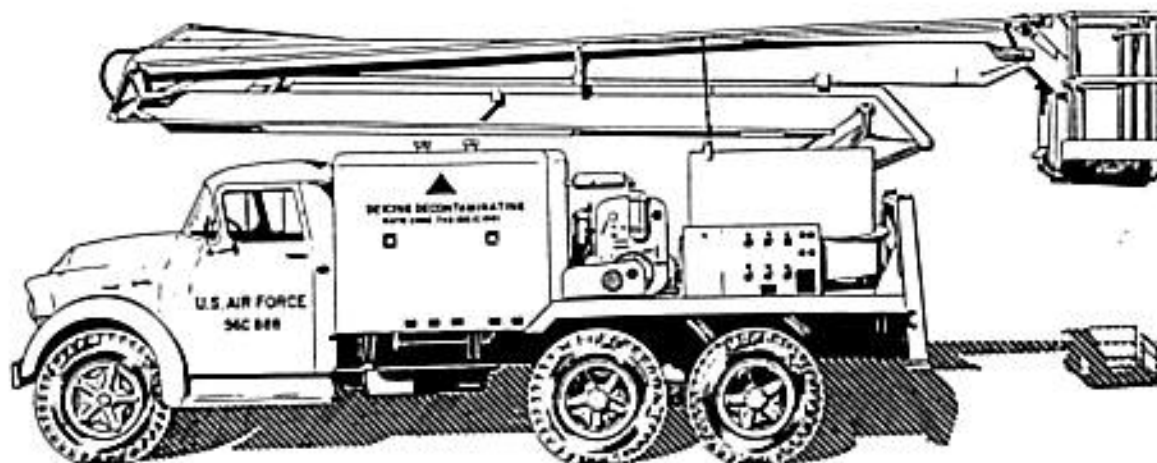

Figure 14F—Side Markings of Deicing-Decontaminating Vehicle

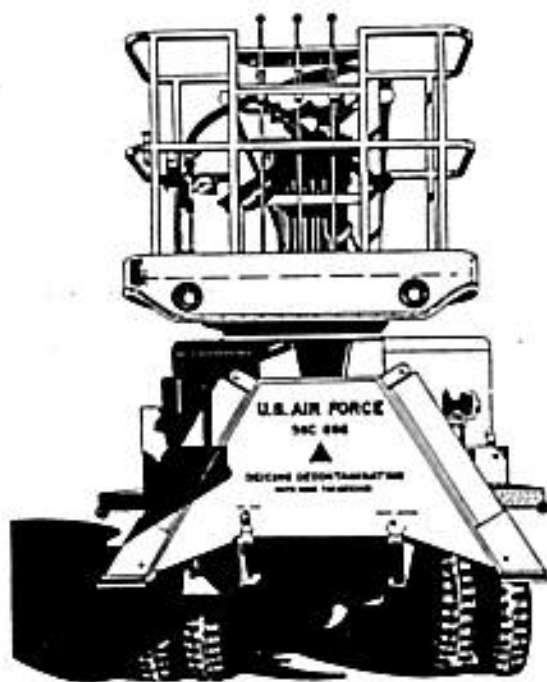

Figure 14G—Rear Markings of Deicing-Decontaminating Vehicle

Figure 14—Fuel and Oil Servicing and De-icing-Decontaminating Vehicles (Cont'd)

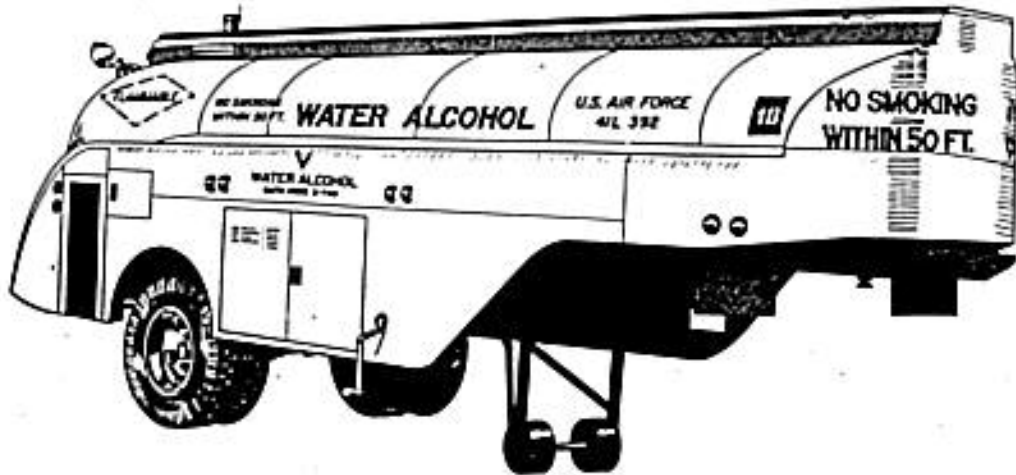

Figure 14H—Side View of Water Alcohol Unit



Figure 14I—Rear View of Water Alcohol Unit

Figure 14—Fuel and Oil Servicing and De-icing-Decontaminating Vehicles (Cont'd)

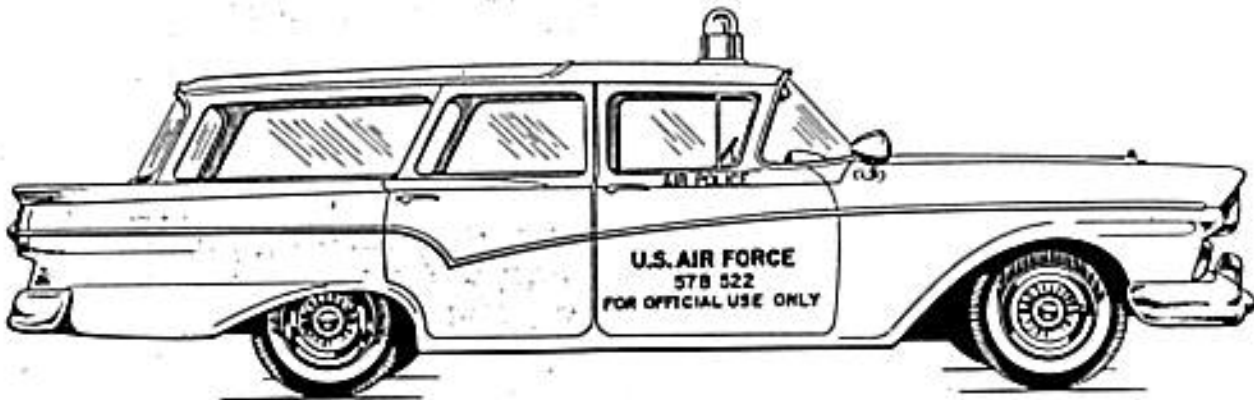

Figure 15A—Air Police Ford Station Wagon (Side View)



Figure 15C—Air Police Ford Station Wagon (Rear View)



Figure 15B—Air Police Ford Station Wagon (Front View)

Figure 15—Air Police Carryalls and Station Wagons

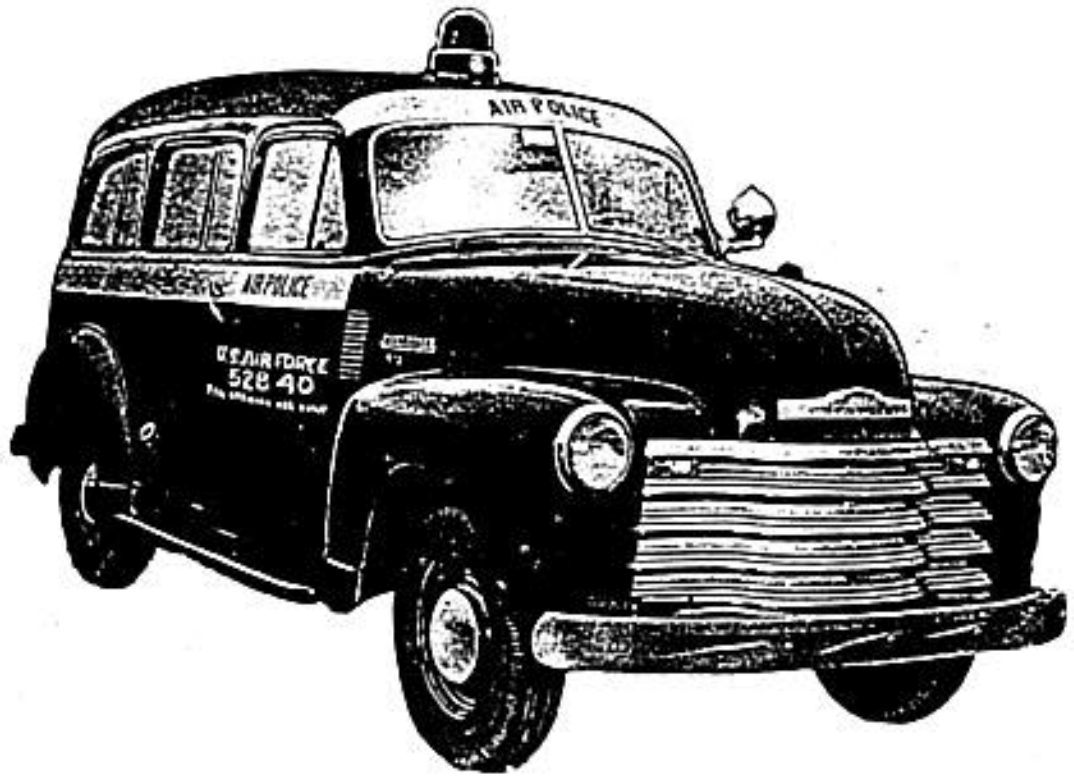

Figure 15D—Three-Quarter View



Figure 15E—Rear View

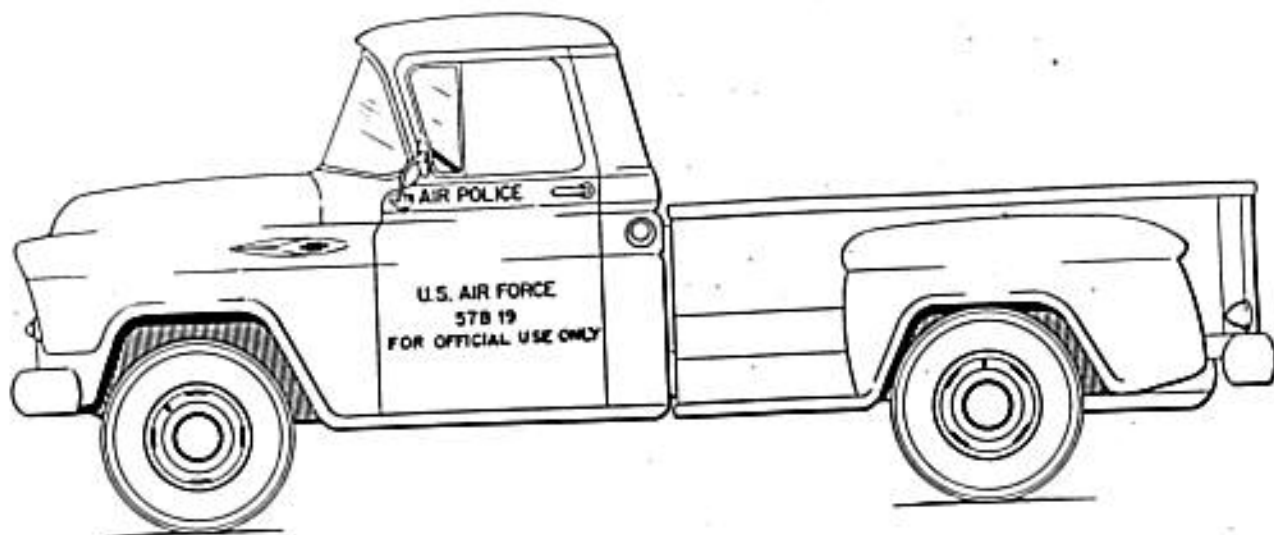

Figure 16A—1/2 Ton, 4x2 (Side View)



Figure 16B—1/2 Ton 4x2 (Front View)



Figure 16C—1/2 Ton, 4x2 (Rear View)

Figure 16—Air Police 1/2-Ton Truck

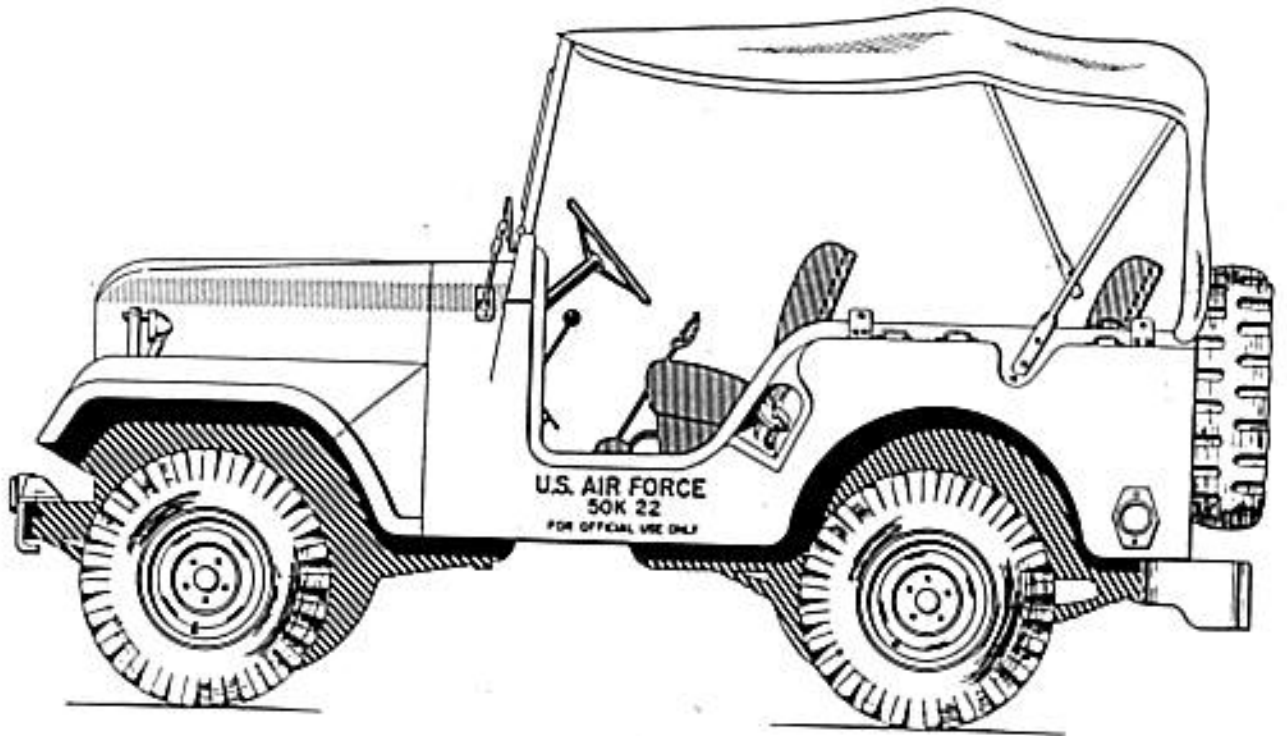

Figure 17A—1/4 Ton 4x4 (Side View)



Figure 17B—1/4 Ton 4x4 (Front View)

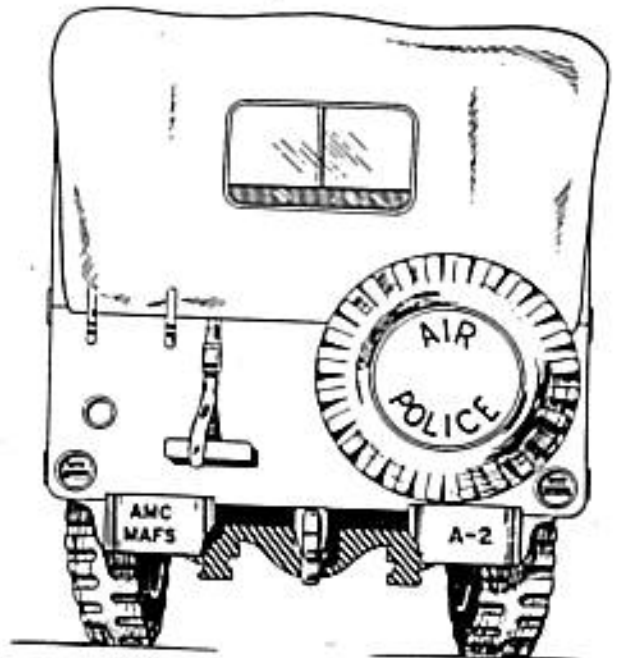
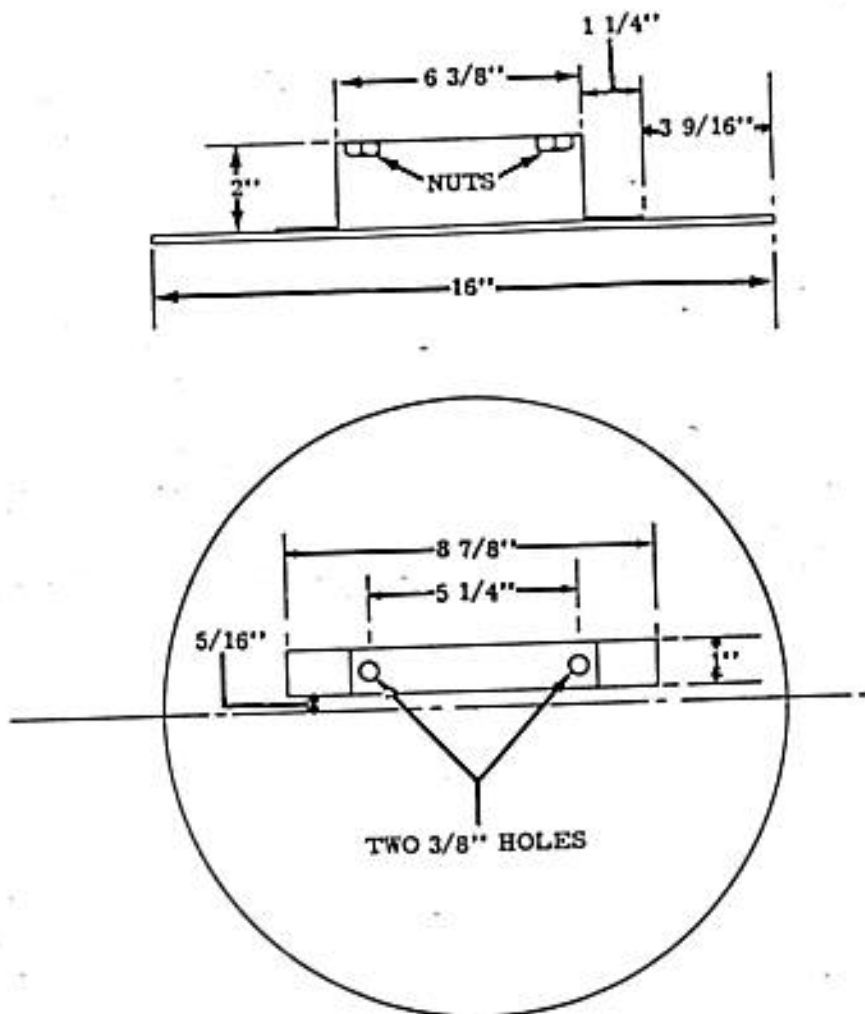

Figure 17C—1/4 Ton 4x4 (Rear View)

Figure 17—Air Police Jeep



Recommended list of materials

- 1 Disc 16" Diameter (Minimum thickness 21 gage - 0.032 in.)
- 1 Steel bracket 1/16" x 1" - Developed length 13"
- 2 Wing bolts 3/8" x 7/8" NF (Corrosion resisting)
- 2 Nuts 3/8" NF (Corrosion resisting)

NOTE:

Bracket should be screwed, riveted or welded to disc
Nuts should be soldered or welded to bracket

Figure 18-Diagram of Air Police Sign Shown in Figure 17C

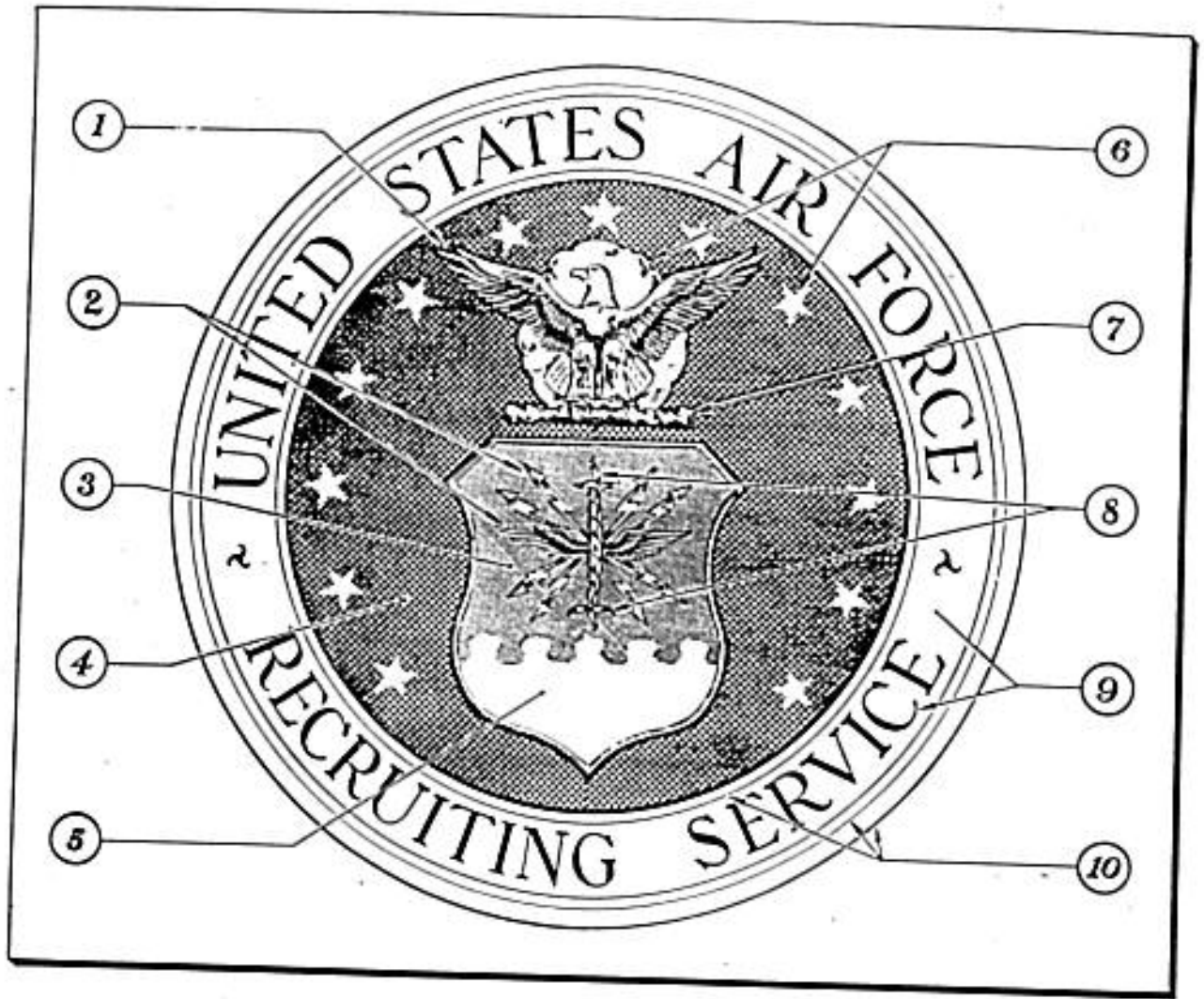

Figure 19—Recruiting Service Decal

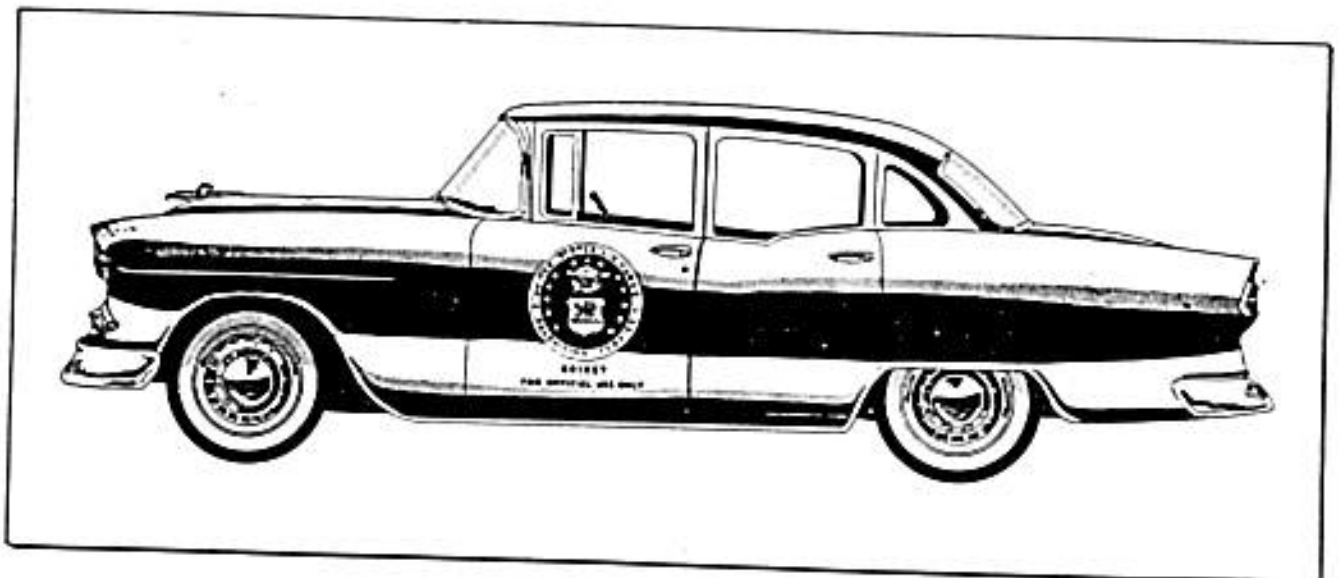

Figure 20—Recruiting Vehicle

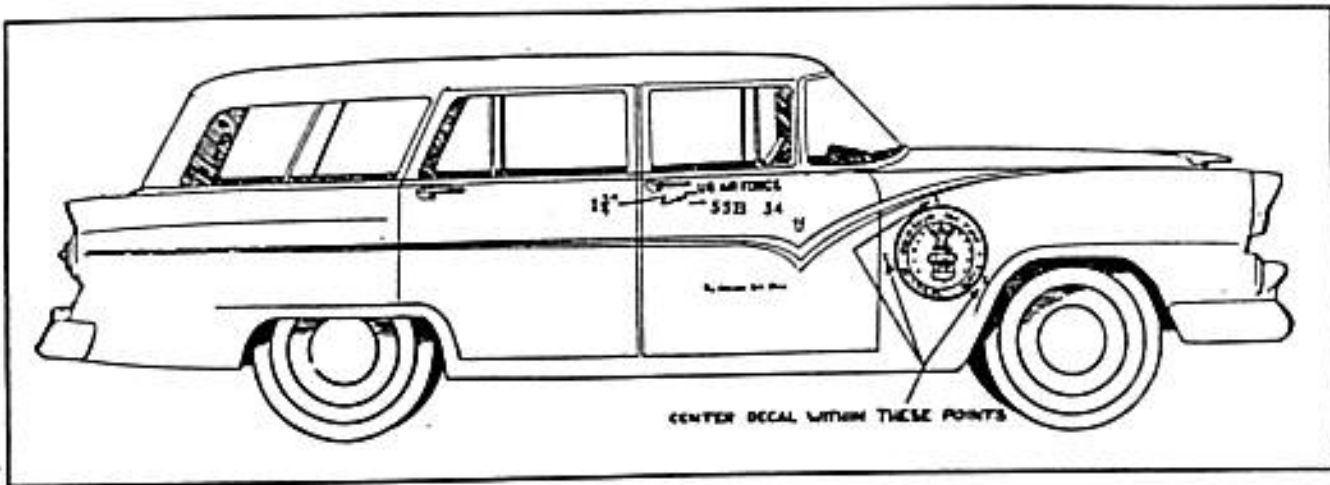

Figure 21—1955 Ford Station Wagon

MPH	KPH
10	16
20	32
30	48
40	64
50	80
60	96

Figure 22—Decal, MPH to KPH

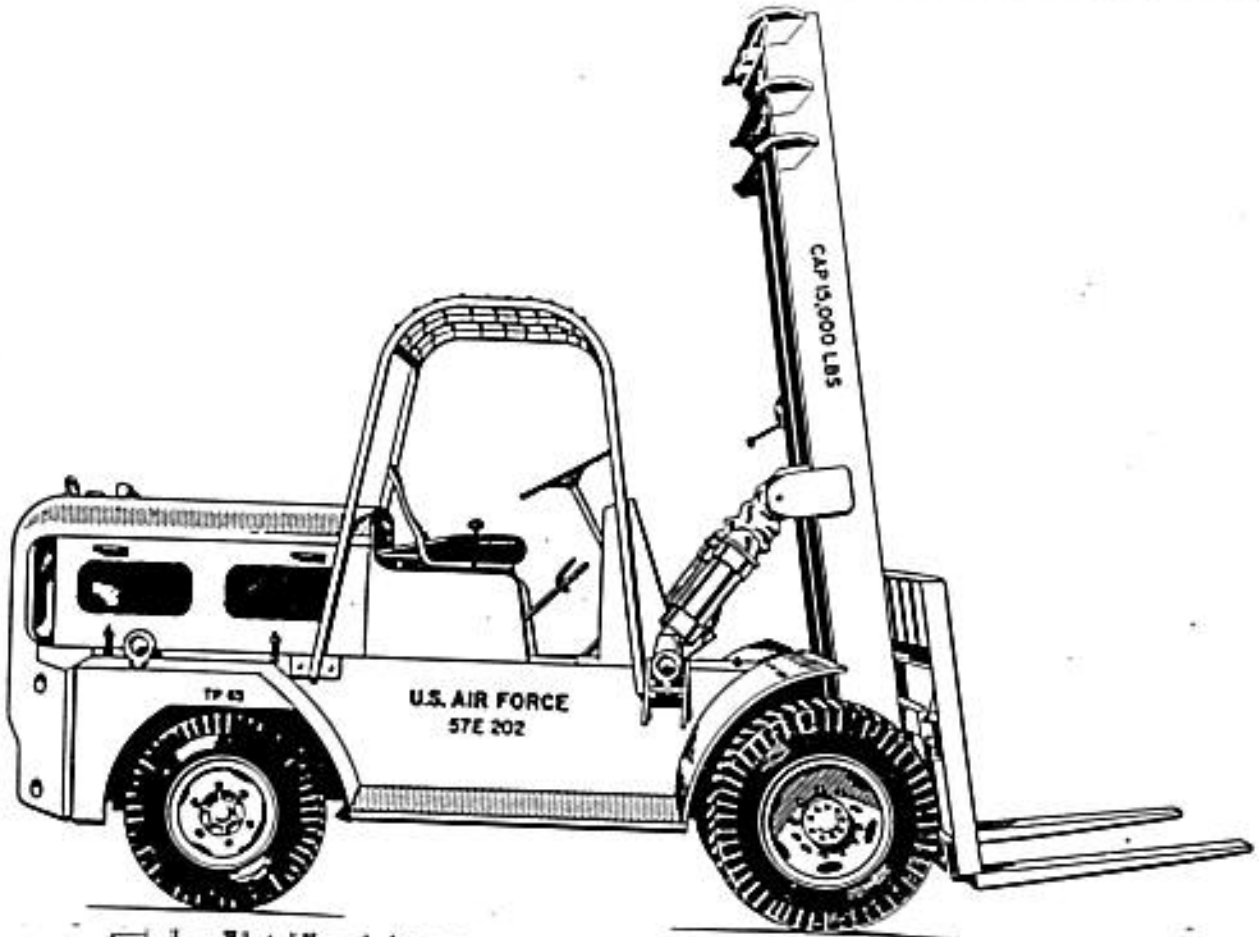

Figure 23A—Truck, Forklift (Side View)



Figure 23B—Truck, Forklift (Rear View)

Figure 23—Truck, Forklift

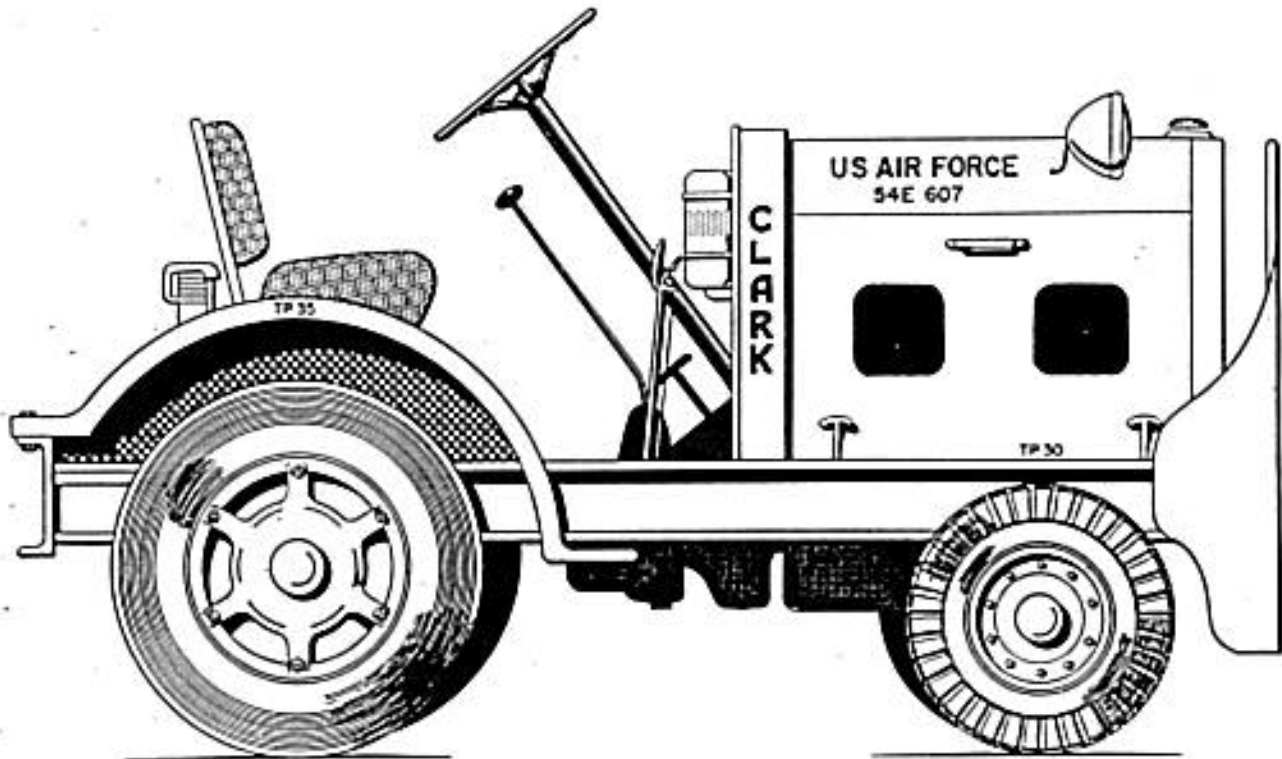

Figure 24A—Tractor, Warehouse (Side View)

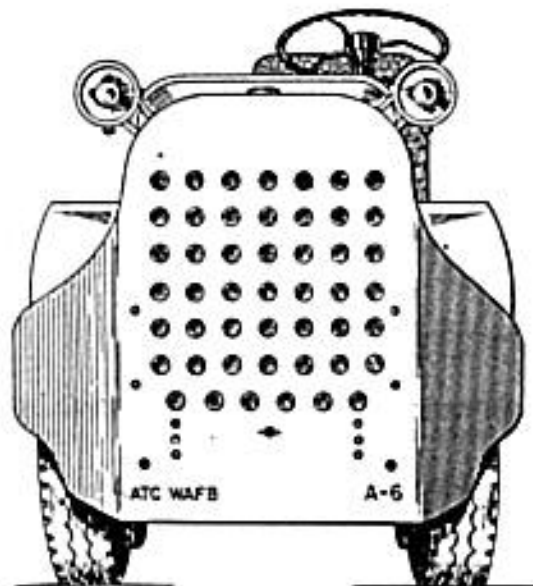

Figure 24B—Tractor, Warehouse (Front View)

Figure 24—Tractor, Warehouse

SECTION V

MATERIAL REQUIRED FOR PAINTING AND MARKING

1. SUPPLY INFORMATION.

The following materials are required for compliance with this technical order:

STOCK NO.	NOMENCLATURE	SOURCE
6810-261-7453	Kerosine	FSC 6810
6810-223-2734	Trichloroethylene	FSC 6810
51-A-1302	Acid—phosphoric	Ordnance Stock
51-C-1581-555	Compound—grease cleaning	Ordnance Stock
8010-316-0598	Primer—synthetic refinishing	FSC 8010
7510-266-6712	Tape—masking, scotch, manila, crepe-backed, 1 in., spec Fed UU-T-106, type I	FSC 7510
6751-812000	Tape—adhesive, moistureproof, red, 2 in. wide	AF Class 43
9515-640-4201	Steel Sheet—carbon, hot rolled; annealed; 0.063 in. thk, spec Fed QQ-S-636	FSC 9515
6850-270-4008	Cleaning Compound—high pressure cleaner; powder or granular form; spec USAF 14128A, for cleaning metal surfaces	FSC 6850
8305-170-5062	Cloth—cotton, cheesecloth; unshrunk; white; 36-in. wd; spec Fed CCC-C-271a, construction II, class B, except wt	FSC 8305
8030-291-0334	Compound—coating; bituminous; solvent; natural or petroleum asphalt with filler asbestos for a protective coating and sound deadener on underbody parts of automotive equipment; spec Fed TT-C-520; Minn Mining, EXP-18030	FSC 8030
5970-280-4920	Compound—insulating, electrical, liquid, for spec MIL-V-1137, type AN, grade CA	FSC 5970
8010-597-7864	Enamel—gray, color designation no. 1610, full gloss; spec MIL-E-7729, type I	FSC 8010
8010-597-7846	Enamel—red, color designation no. 1105, full gloss; spec MIL-E-7729, type I	FSC 8010
8010-663-3041	Enamel—white, color designation no. 1755, spec MIL-E-7729, type I	FSC 8010
8010-598-5947	Enamel—yellow, color designation no. 1310, full gloss; spec MIL-E-7729, type I	FSC 8010

STOCK NO.	NOMENCLATURE	SOURCE
8010-598-5451	Sealer—surface; varnish type; w/fungicide; spec A, 3-185, type II	FSC 8010
8010-598-5945	Enamel—yellow, color designation no. 1320, full gloss; spec MIL-E-7729, type I	FSC 8010
8010-598-5948	Enamel—blue, color designation no. 516, full gloss; spec MIL-E-7729, type I	FSC 8010
8010-664-6674	Enamel—black, color designation no. 1775, full gloss; spec MIL-E-5557, type I	FSC 8010
8010-514-1249	Enamel—green, color designation no. 2415, semigloss; spec Fed TT-E-529, class A	FSC 8010
8010-663-3034	Lacquer—cellulosic derivative type; colorless; full gloss; spec MIL-L-7178	FSC 8010
8010-598-5933	Lacquer—cellulosic derivative type; blue pigmented, color designation no. 516, full gloss; spec MIL-L-7178	FSC 8010
8010-248-2838	Lacquer—cellulosic derivative type; yellow pigmented, color designation no. 1310, full gloss; spec MIL-L-7178	FSC 8010
8010-251-6506	Lacquer—cellulosic derivative type; white pigmented, color designation no. 1755, full gloss; spec MIL-L-7178	FSC 8010
8010-161-7384	Lacquer—cellulosic derivative type; red pigmented; color designation no. 1105, full gloss; spec MIL-L-7178	FSC 8010
6850-244-8975	Cleaning Compound—solvent; emulsion type; for use on aluminum surfaces; spec USAF 20015-E	FSC 6850
8030-664-4969	Paint—bituminous coal tar, pitch base, spec MIL-P-6883	FSC 8030
8010-161-7274	Primer Coating—metal; lacquer-proof, iron oxide red, spec TT-P-664.	FSC 8010
8010-246-0872	Primer Coating—metal; zinc chromate, spec MIL-P-6889A, amend 4, type I	FSC 8010
8010-165-5536	Remover—paint and varnish; alkali type; powder form, spec MIL-R-25134	FSC 8010
8010-162-5289	Thinner—dope and lacquer; cellulose nitrate base; spec MIL-T-6095	FSC 8010
8010-664-4961	Thinner—synthetic resin enamel; spec TT-T-306	FSC 8010
5345-186-8243	Disk—abrasive; open coating; grade no. 3 overall diameter 9 1/8 in; w/o arbor hole	FSC 5345
5345-186-8240	Disk—abrasive; open coating, grade no. 2, 7 in. diameter; w/o arbor hole	FSC 5345
5345-186-8256	Disk—abrasive, open coating, grade no. 4, 7 in. diameter; w/o arbor hole	FSC 5345

STOCK NO.	NOMENCLATURE	SOURCE
5345-186-8248	Disk—abrasive open coating, grade no. 0, 7 in. diameter, w/o arbor hole	FSC 5345
4240-270-4400	Respirator—air filtering, spec N, 37M3b, type A, class 1	FSC 4240
6810-223-9067	Naptha—aromatic, spec TT-N-97, type II	FSC 6810
8030-281-2718	Wood Preservative—pentachlorophenol mixture; spec MIL-P-00906C (SHIPS), type B	FSC 8030
Not Listed	Coating—pretreatment, for metals; spec MIL-C-15328A	AF Stock
Not Listed	Strip of red reflectorized tape 10 in. wide with the words "NO SMOKING WITHIN 50 FT" in 4-in. silver letters	Local Purchase
Not Listed	Strip of red reflectorized tape 7 in. wide with the word "FLAMMABLE" in 6-in. silver letters	Local Purchase
Not Listed	Strip of red reflectorized tape 11 in. wide and 11 feet long with "FUMING NITRIC ACID" in 10-in. silver letters	Local Purchase
Not Listed	Strip of silver tape 5 in. wide with "AIR POLICE" in 4-in. blue letters	Local Purchase
Not Listed	Strip of red reflectorized tape 4 in. wide and 4 in. long	Local Purchase
Not Listed	Strip of red reflectorized tape 8 in. wide and 8 in. long	Local Purchase
Not Listed	Strip of red reflectorized tape 12 in. wide and 12 in. long	Local Purchase
Not Listed	Strip of red reflectorized tape 5 in. wide, with "U. S. AIR FORCE" in 4-in. silver letters	Local Purchase
Not Listed	Strip of blue reflectorized tape 5 in. wide with "U. S. AIR FORCE" in 4-in. yellow letters	Local Purchase
Not Listed	Strip of red reflectorized tape 2 3/4 in. wide with "U. S. AIR FORCE" in 1 3/4-inch silver letters	Local Purchase
Not Listed	Strip of blue reflectorized tape 2 3/4 in. wide with "U. S. AIR FORCE" in 1 3/4-in. yellow letters	Local Purchase
Not Listed	Strip of red reflectorized tape 2 in. wide with "U. S. AIR FORCE" in 1-in. silver letters	Local Purchase
Not Listed	Strip of blue reflectorized tape 2 in. wide with "U. S. AIR FORCE" in 1-in. yellow letters	Local Purchase
Not Listed	Strip of red reflectorized tape 5 in. wide with "AIR NATIONAL GUARD" in 4-in. silver letters	Local Purchase
Not Listed	Strip of blue reflectorized tape 5 in. wide with "AIR NATIONAL GUARD" in 4-in. yellow letters	Local Purchase

STOCK NO.	NOMENCLATURE	SOURCE
Not Listed	Strip of red reflectorized tape 2 3/4 in. wide with "AIR NATIONAL GUARD" in 1 3/4-in. silver letters	Local Purchase
Not Listed	Strip of blue reflectorized tape 2 3/4 in. wide with "AIR NATIONAL GUARD" in 1 3/4-in. yellow letters	Local Purchase
Not Listed	Strip of red reflectorized tape 2 in. wide with "AIR NATIONAL GUARD" in 1-in. silver letters	Local Purchase
Not Listed	Strip of blue reflectorized tape 2 in. wide with "AIR NATIONAL GUARD" in 1-in. yellow letters	Local Purchase
Not Listed	Strip of red reflectorized tape 4 in. wide with ten 0's in 3-in. silver numbers	Local Purchase
Not Listed	Strip of blue reflectorized tape 4 in. wide with ten 0's in 3-in. yellow numbers	Local Purchase
Not Listed	Strip of red reflectorized tape 4 in. wide with ten 1's in 3-in. silver numbers	Local Purchase
Not Listed	Strip of blue reflectorized tape 4 in. wide with ten 1's in 3-in. yellow numbers	Local Purchase
Not Listed	Strip of red reflectorized tape 4 in wide, with ten 2's in 3-in. silver numbers	Local Purchase
Not Listed	Strip of blue reflectorized tape 4 in. wide, with ten 2's in 3-in. yellow numbers	Local Purchase
Not Listed	Strip of red reflectorized tape 4 in. wide, with ten 3's in 3-in. silver numbers	Local Purchase
Not Listed	Strip of blue reflectorized tape 4 in. wide with ten 3's in 3-in. yellow numbers	Local Purchase
Not Listed	Strip of red reflectorized tape 4 in. wide with ten 4's in 3-in. silver numbers	Local Purchase
Not Listed	Strip of blue reflectorized tape 4 in. wide with ten 4's in 3-in. yellow numbers	Local Purchase
Not Listed	Strip of red reflectorized tape 4 in. wide with ten 5's in 3-in. silver numbers	Local Purchase
Not Listed	Strip of blue reflectorized tape 4 in. wide with ten 5's in 3-in. yellow numbers	Local Purchase
Not Listed	Strip of red reflectorized tape 4 in. wide with ten 6's in 3-in silver numbers	Local Purchase
Not Listed	Strip of blue reflectorized tape 4 in. wide with ten 6's in 3-in. yellow numbers	Local Purchase
Not Listed	Strip of red reflectorized tape 4 in. wide with ten 7's in 3-in silver numbers	Local Purchase
Not Listed	Strip of blue reflectorized tape 4 in. wide with ten 7's in 3-in. yellow numbers	Local Purchase

STOCK NO.	NOMENCLATURE	SOURCE
Not Listed	Strip of red reflectorized tape 4 in. wide with ten 8's in 3-in. silver numbers	Local Purchase
Not Listed	Strip of blue reflectorized tape 4 in. wide with ten 8's in 3-in. yellow numbers	Local Purchase
Not Listed	Strip of red reflectorized tape 4 in. wide with ten 9's in 3-in. silver numbers	Local Purchase
Not Listed	Strip of blue reflectorized tape 4 in. wide with ten 9's in 3-in. yellow numbers	Local Purchase
Not Listed	Strip of red reflectorized tape 2 3/4 in. wide with ten 0's in 1 3/4-in. silver numbers	Local Purchase
Not Listed	Strip of blue reflectorized tape 2 3/4 in. wide with ten 0's in 1 3/4-in. yellow numbers	Local Purchase
Not Listed	Strip of red reflectorized tape 2 3/4 in. wide with ten 1's in 1 3/4-in. silver numbers	Local Purchase
Not Listed	Strip of blue reflectorized tape 2 3/4 in. wide with ten 1's in 1 3/4-in. yellow numbers	Local Purchase
Not Listed	Strip of red reflectorized tape 2 3/4 in. wide with ten 2's in 1 3/4-in. silver numbers	Local Purchase
Not Listed	Strip of blue reflectorized tape 2 3/4 in. wide with ten 2's in 1 3/4-in. yellow numbers	Local Purchase
Not Listed	Strip of red reflectorized tape 2 3/4 in. wide with ten 3's in 1 3/4-in. silver numbers	Local Purchase
Not Listed	Strip of blue reflectorized tape 2 3/4 in. wide with ten 3's in 1 3/4-in. yellow numbers	Local Purchase
Not Listed	Strip of red reflectorized tape 2 3/4 in. wide with ten 4's in 1 3/4-in. silver numbers	Local Purchase
Not Listed	Strip of blue reflectorized tape 2 3/4 in. wide with ten 4's in 1 3/4-in. yellow numbers	Local Purchase
Not Listed	Strip of red reflectorized tape 2 3/4 in. wide with ten 5's in 1 3/4-in. silver numbers	Local Purchase
Not Listed	Strip of blue reflectorized tape 2 3/4 in. wide with ten 5's in 1 3/4-in. yellow numbers	Local Purchase
Not Listed	Strip of red reflectorized tape 2 3/4 in. wide with ten 6's in 1 3/4-in. silver numbers	Local Purchase
Not Listed	Strip of blue reflectorized tape 2 3/4 in. wide with ten 6's in 1 3/4-in. yellow numbers	Local Purchase
Not Listed	Strip of red reflectorized tape 2 3/4 in. wide with ten 7's in 1 3/4-in. silver numbers	Local Purchase
Not Listed	Strip of blue reflectorized tape 2 3/4 in. wide with ten 7's in 1 3/4-in. yellow numbers	Local Purchase
Not Listed	Strip of red reflectorized tape 2 3/4 in. wide with ten 8's in 1 3/4-in. silver numbers	Local Purchase

STOCK NO.	NOMENCLATURE	SOURCE
Not Listed	Strip of blue reflectorized tape 2 3/4 in. wide with ten 8's in 1 3/4-in. yellow numbers	Local Purchase
Not Listed	Strip of red reflectorized tape 2 3/4 in. wide with ten 9's in 1 3/4-in. silver numbers	Local Purchase
Not Listed	Strip of blue reflectorized tape 2 3/4 in. wide with ten 9's in 1 3/4-in. yellow numbers	Local Purchase
Not Listed	Strip of red reflectorized tape 2 in. wide with ten 0's in 1-in. silver numbers	Local Purchase
Not Listed	Strip of blue reflectorized tape 2 in. wide with ten 0's in 1-in. yellow numbers	Local Purchase
Not Listed	Strip of red reflectorized tape 2 in. wide with ten 1's in 1-in. silver numbers	Local Purchase
Not Listed	Strip of blue reflectorized tape 2 in. wide with ten 1's in 1-in. yellow numbers	Local Purchase
Not Listed	Strip of red reflectorized tape 2 in. wide with ten 2's in 1-in. silver numbers	Local Purchase
Not Listed	Strip of blue reflectorized tape 2 in. wide with ten 2's in 1-in. yellow numbers	Local Purchase
Not Listed	Strip of red reflectorized tape 2 in. wide with ten 3's in 1-in. silver numbers	Local Purchase
Not Listed	Strip of blue reflectorized tape 2 in. wide with ten 3's in 1-in. yellow numbers	Local Purchase
Not Listed	Strip of red reflectorized tape 2 in. wide with ten 4's in 1-in. silver numbers	Local Purchase
Not Listed	Strip of blue reflectorized tape 2 in. wide with ten 4's in 1-in. yellow numbers	Local Purchase
Not Listed	Strip of red reflectorized tape 2 in. wide with ten 5's in 1-in. silver numbers	Local Purchase
Not Listed	Strip of blue reflectorized tape 2 in. wide with ten 5's in 1-in. yellow numbers	Local Purchase
Not Listed	Strip of red reflectorized tape 2 in. wide with ten 6's in 1-in. silver numbers	Local Purchase
Not Listed	Strip of blue reflectorized tape 2 in. wide with ten 6's in 1-in. yellow numbers	Local Purchase
Not Listed	Strip of red reflectorized tape 2 in. wide with ten 7's in 1-in. silver numbers	Local Purchase
Not Listed	Strip of blue reflectorized tape 2 in. wide with ten 7's in 1-in. yellow numbers	Local Purchase
Not Listed	Strip of red reflectorized tape 2 in. wide with ten 8's in 1-in. silver numbers	Local Purchase
Not Listed	Strip of blue reflectorized tape 2 in. wide with ten 8's in 1-in. yellow numbers	Local Purchase

STOCK NO.	NOMENCLATURE	SOURCE
Not Listed	Strip of red reflectorized tape 2 in. wide with ten 9's in 1-in. silver numbers	Local Purchase
Not Listed	Strip of blue reflectorized tape 2 in. wide with ten 9's in 1-in. yellow numbers	Local Purchase
Not Listed	Strip of red reflectorized tape 2 in. wide with "FOR OFFICIAL USE ONLY" in 1-in. silver letters	Local Purchase
Not Listed	Strip of blue reflectorized tape 2 in. wide with "FOR OFFICIAL USE ONLY" in 1-in. yellow letters	Local Purchase
Not Listed	Strip of red reflectorized tape 4 in. wide, with ten B's in 3-in. silver letters	Local Purchase
Not Listed	Strip of blue reflectorized tape 4 in. wide with ten B's in 3-in. yellow letters	Local Purchase
Not Listed	Strip of red reflectorized tape 4 in. wide with ten C's in 3-in. silver letters	Local Purchase
Not Listed	Strip of blue reflectorized tape 4 in. wide with ten C's in 3-in. yellow letters	Local Purchase
Not Listed	Strip of red reflectorized tape 4 in. wide with ten D's in 3-in. silver letters	Local Purchase
Not Listed	Strip of blue reflectorized tape 4 in. wide with ten D's in 3-in. yellow letters	Local Purchase
Not Listed	Strip of red reflectorized tape 4 in. wide with ten E's in 3-in. silver letters	Local Purchase
Not Listed	Strip of blue reflectorized tape 4 in. wide with ten E's in 3-in. yellow letters	Local Purchase
Not Listed	Strip of red reflectorized tape 4 in. wide with ten K's in 3-in. silver letters	Local Purchase
Not Listed	Strip of blue reflectorized tape 4 in. wide with ten K's in 3-in. yellow letters	Local Purchase
Not Listed	Strip of red reflectorized tape 4 in. wide with ten L's in 3-in. silver letters	Local Purchase
Not Listed	Strip of blue reflectorized tape 4 in. wide with ten L's in 3-in. yellow letters	Local Purchase
Not Listed	Strip of red reflectorized tape 4 in. wide with ten M's in 3-in. silver letters	Local Purchase
Not Listed	Strip of blue reflectorized tape 4 in. wide with ten M's in 3-in. yellow letters	Local Purchase
Not Listed	Strip of red reflectorized tape 4 in. wide with ten N's in 3-in. silver letters	Local Purchase
Not Listed	Strip of blue reflectorized tape 4 in. wide with ten N's in 3-in. yellow letters	Local Purchase
Not Listed	Strip of red reflectorized tape 2 3/4 in. wide with ten B's in 1 3/4-in. silver letters	Local Purchase

STOCK NO.	NOMENCLATURE	SOURCE
Not Listed	Strip of blue reflectorized tape 2 3/4 in. wide with ten B's in 1 3/4-in. yellow letters	Local Purchase
Not Listed	Strip of red reflectorized tape 2 3/4 in. wide with ten C's in 1 3/4-in. silver letters	Local Purchase
Not Listed	Strip of blue reflectorized tape 2 3/4 in. wide with ten C's in 1 3/4-in. yellow letters	Local Purchase
Not Listed	Strip of red reflectorized tape 2 3/4 in. wide with ten D's in 1 3/4-in. silver letters	Local Purchase
Not Listed	Strip of blue reflectorized tape 2 3/4 in. wide with ten D's in 1 3/4-in. yellow letters	Local Purchase
Not Listed	Strip of red reflectorized tape 2 3/4 in. wide with ten E's in 1 3/4-in. silver letters	Local Purchase
Not Listed	Strip of blue reflectorized tape 2 3/4 in. wide with ten E's in 1 3/4-in. yellow letters	Local Purchase
Not Listed	Strip of red reflectorized tape 2 3/4 in. wide with ten K's in 1 3/4-in. silver letters	Local Purchase
Not Listed	Strip of blue reflectorized tape 2 3/4 in. wide with ten K's in 1 3/4-in. yellow letters	Local Purchase
Not Listed	Strip of red reflectorized tape 2 3/4 in. wide with ten L's in 1 3/4-in. silver letters	Local Purchase
Not Listed	Strip of blue reflectorized tape 2 3/4 in. wide with ten L's in 1 3/4-in. yellow letters	Local Purchase
Not Listed	Strip of red reflectorized tape 2 3/4 in. wide with ten M's in 1 3/4-in. silver letters	Local Purchase
Not Listed	Strip of blue reflectorized tape 2 3/4 in. wide with ten M's in 1 3/4-in. yellow letters	Local Purchase
Not Listed	Strip of red reflectorized tape 2 3/4 in. wide with ten N's in 1 3/4-in. silver letters	Local Purchase
Not Listed	Strip of blue reflectorized tape 2 3/4 in. wide with ten N's in 1 3/4-in. yellow letters	Local Purchase
Not Listed	Strip of red reflectorized tape 2 in. wide with ten B's in 1-in. silver letters	Local Purchase
Not Listed	Strip of blue reflectorized tape 2 in. wide with ten B's in 1-in. yellow letters	Local Purchase
Not Listed	Strip of red reflectorized tape 2 in. wide with ten C's in 1-in. silver letters	Local Purchase
Not Listed	Strip of blue reflectorized tape 2 in. wide with ten C's in 1-in. yellow letters	Local Purchase
Not Listed	Strip of red reflectorized tape 2 in. wide with ten D's in 1-in. silver letters	Local Purchase
Not Listed	Strip of blue reflectorized tape 2 in. wide with ten D's in 1-in. yellow letters	Local Purchase

STOCK NO.	NOMENCLATURE	SOURCE
Not Listed	Strip of red reflectorized tape 2 in. wide with ten E's in 1-in. silver letters	Local Purchase
Not Listed	Strip of blue reflectorized tape 2 in. wide with ten E's in 1-in. yellow letters	Local Purchase
Not Listed	Strip of red reflectorized tape 2 in. wide with ten K's in 1-in. silver letters	Local Purchase
Not Listed	Strip of blue reflectorized tape 2 in. wide with ten K's in 1-in. yellow letters	Local Purchase
Not Listed	Strip of red reflectorized tape 2 in. wide with ten L's in 1-in. silver letters	Local Purchase
Not Listed	Strip of blue reflectorized tape 2 in. wide with ten L's in 1-in. yellow letters	Local Purchase
Not Listed	Strip of red reflectorized tape 2 in. wide with ten M's in 1-in. silver letters	Local Purchase
Not Listed	Strip of blue reflectorized tape 2 in. wide with ten M's in 1-in. yellow letters	Local Purchase
Not Listed	Strip of red reflectorized tape 2 in. wide with ten N's in 1-in. silver letters	Local Purchase
Not Listed	Strip of blue reflectorized tape 2 in. wide with ten N's in 1-in. yellow letters	Local Purchase
Not Listed	Strip of silver reflectorized tape 2 in. wide and 6 in. long with applicable type fuel, symbol, and code number appearing 3 times in black with 1/2-inch letters, and numbers and a 1/2-inch symbol	Local Purchase

