

SCREENS



Screens Numbering System



Fast Screen

41 Fast 42 Fast 43 Fast

X

A

B

F

B or F,
depending on formation

Bubble Screen

42 Bubble 43 Bubble

44
Bubble
F coming
out of backfield

X

A

B

F

B or F,
depending on formation



Fast



System

41
Fast



42
Fast



43
Fast



B or F,
depending on
formation

Blocking Rules

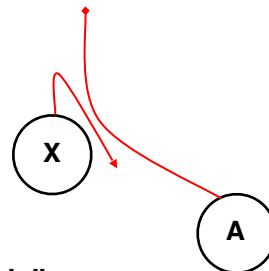

“Fast Hands”
If off coverage, gain 2
yards, turn for ball

Step on toes of “X” to
Most Dangerous

41-Fast-Lion/Roar

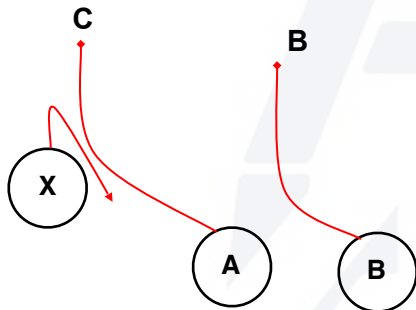

41-Fast- “X”

Prefer this against off
coverage

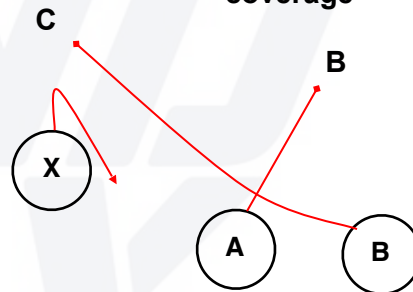

42-Fast-Lion/Roar

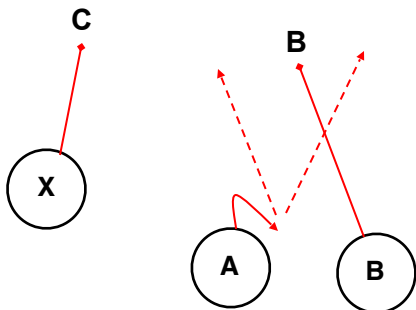

Cheat splits, read block
by B

43-Fast-Lion/Roar

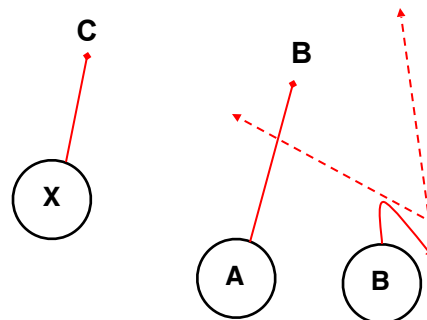

Cheat splits, read block
by A



Bubble



System

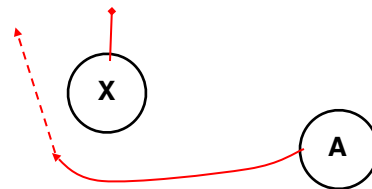
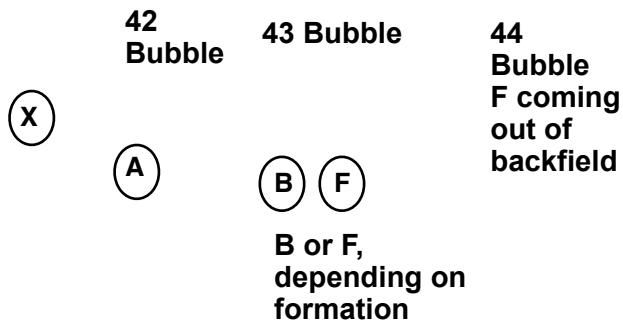

Block Most Dangerous

If don't catch now, go up now

Bubble

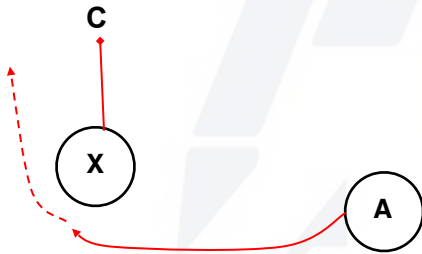

Lion-Bubble

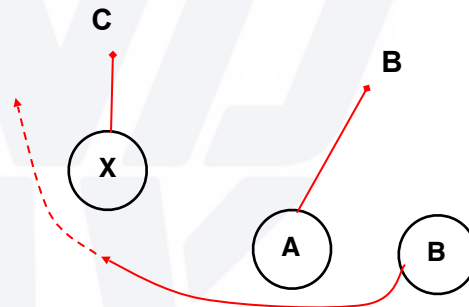

Empty Bubble

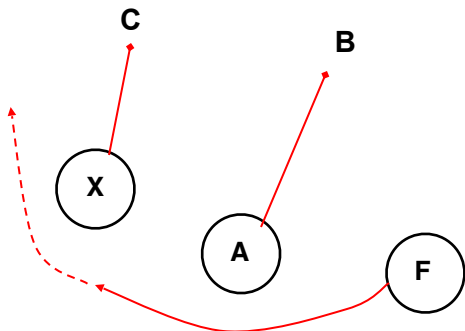

Pair with Plays

- All Strong Runs
- QB Jet as an RPO



Rocket Base Rules

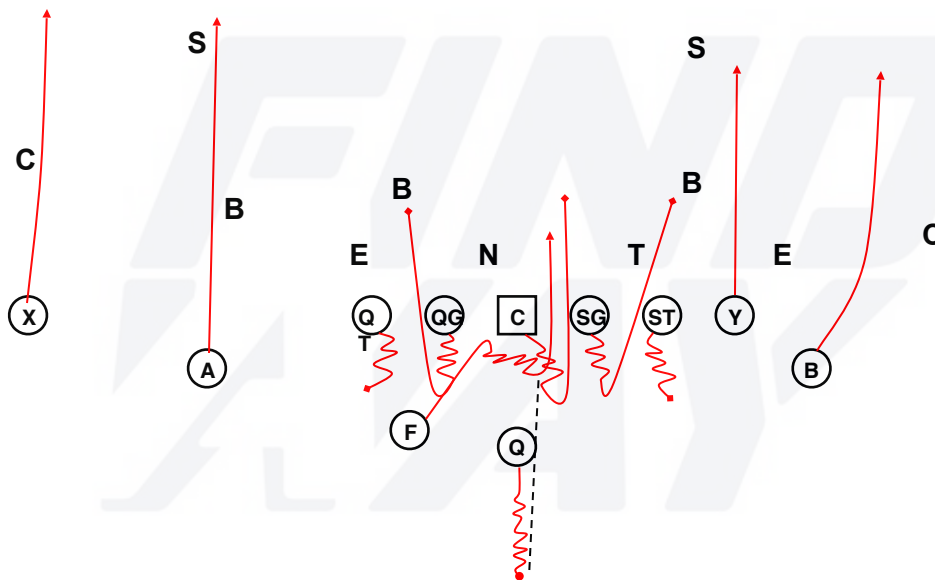

Position	Job Description
X	Go route
A	Go route
F	Step up for 2 counts, run away from any DL
Y	Go route
B	Go route
QT	Pass protect
QG	Show Pass for 1 count, then release to ILB
C	Show pass for 1 count, then release to most dangerous linebacker
SG	Show pass for 1 count, then release to ILB
ST	Pass protect
Q	Bail 3 steps and sit, then fade back to draw rush



Rocket Variations



Empty-B-Rocket^B

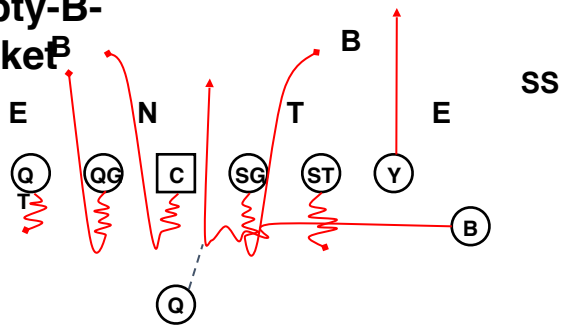

B Rocket

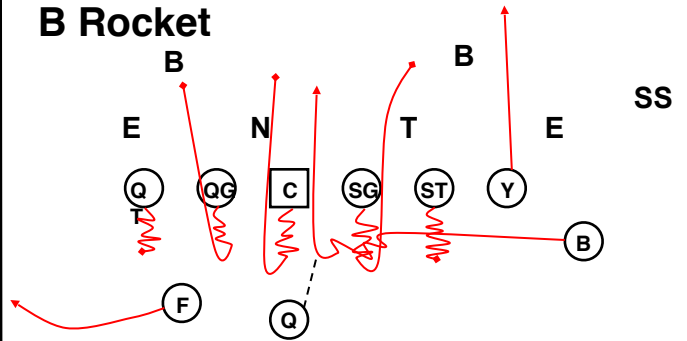

Squeeze-Bus-A Rocket

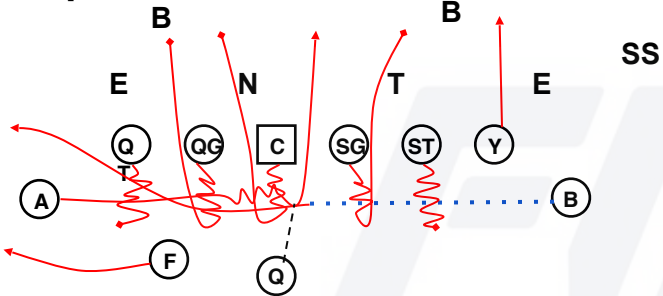

Bus Rocket

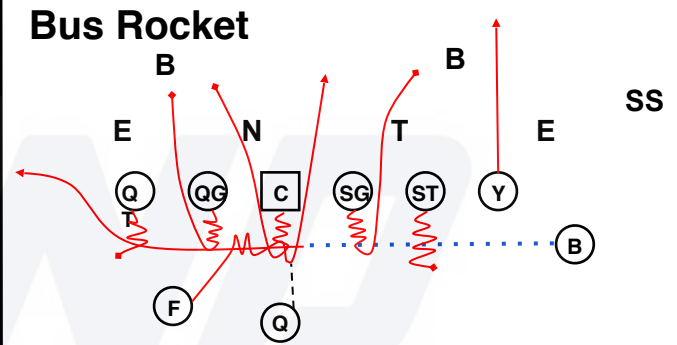



Laser

Base Rules

Like vs aggressive DE

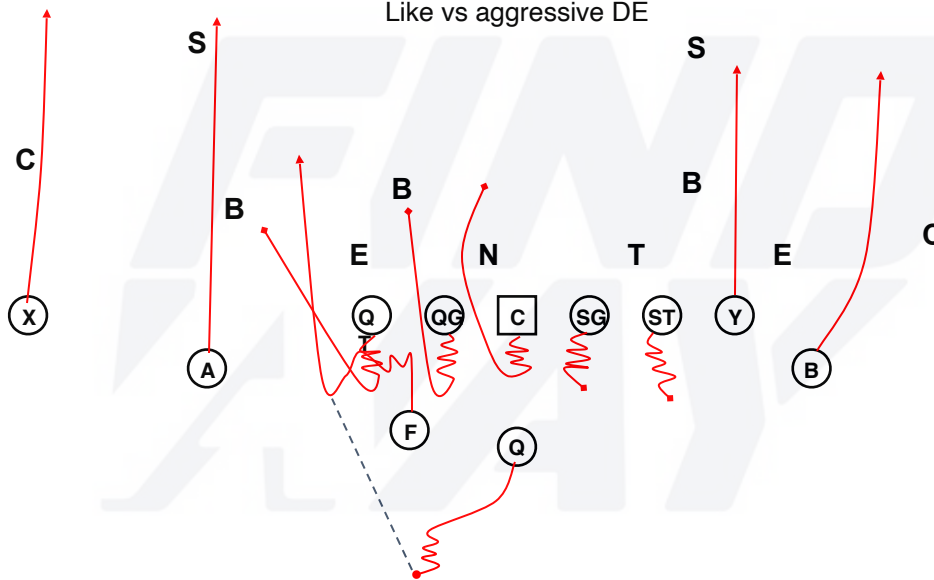

Position	Job Description
X	Go route
A	Go route
F	Attack edge for 1 count, then drift wide
Y	Go route
B	Go route
QT	Show pass for 1 count, then kick OLB
QG	Show Pass for 1 count, then release to ILB
C	Show pass for 1 count, then release to backside ILB
SG	Pass protect
ST	Pass protect
Q	Half roll for 3 steps and set, then drift to draw defense



Flavors of Laser



Red-Bus-Laser

